

Slide Bracket Wall and Console

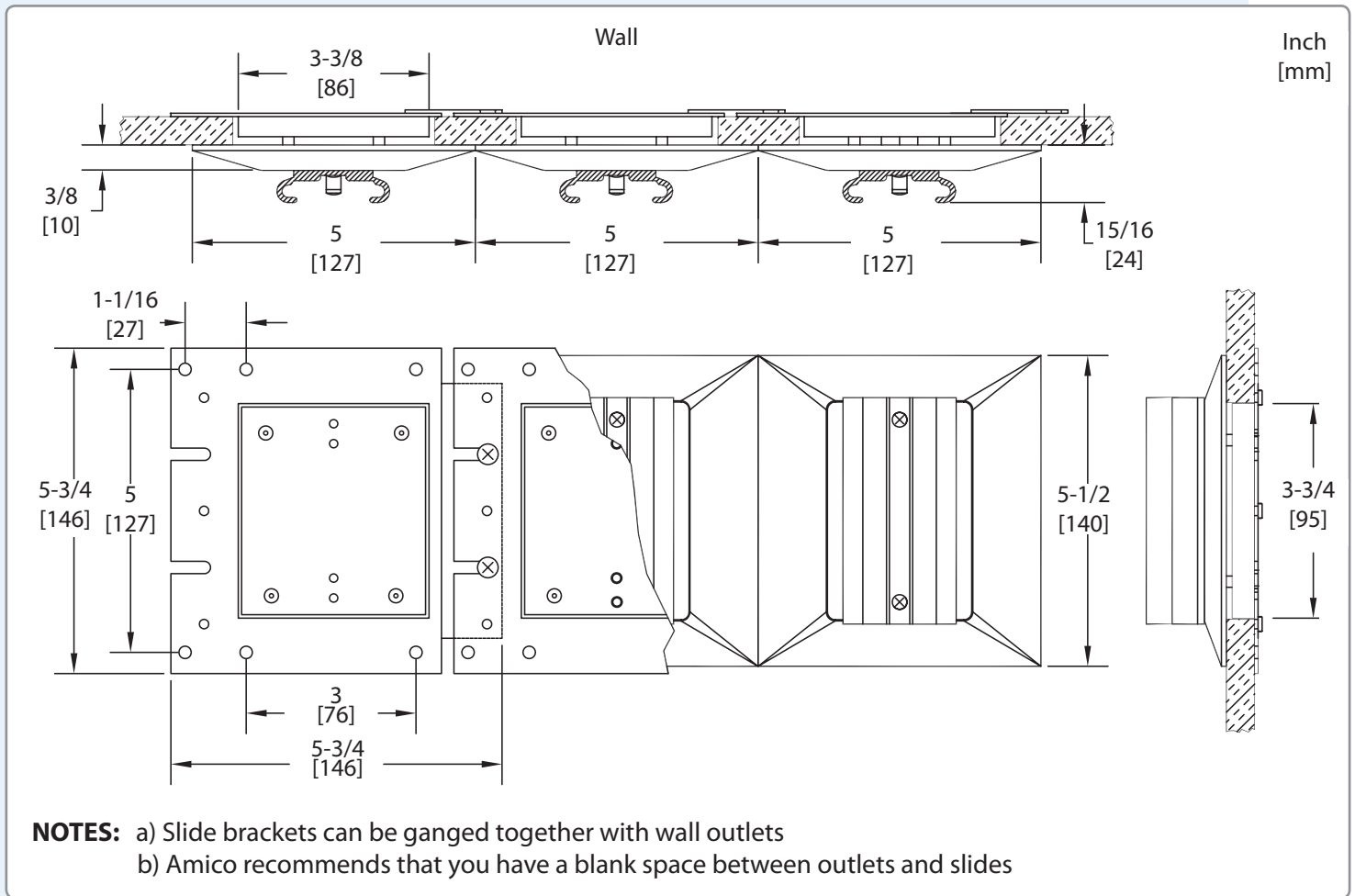

Console

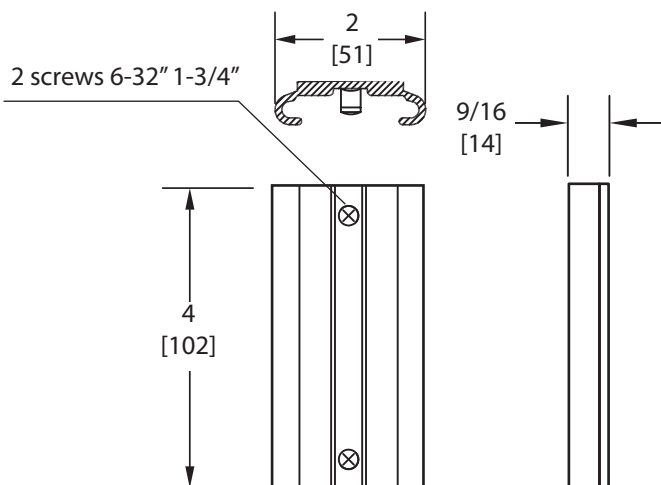

Model Numbers

Wall Slide: **O-WALSLIDE**
 Wall Slide (Satin Finish): **O-WALSLIDE-G**
 Console Slide: **O-CONSLIDE**

Materials of Construction

Slide: Anodized Aluminium
 Stopper: Nylon
 Screws: Plated Steel
 Cover Plate: Chrome plated ZINC
 Back-Assembly: Plated Steel

Available for M.R.I.

Wall Slide M.R.I.: **O-WALSLIDE-M**
 Wall Slide M.R.I. (Satin Finish): **O-WALSLIDE-M-G**
 Console Slide M.R.I.: **O-CONSLIDE-M**

Technical Specifications

