

Retro-Fit Manual NCG Chemetron



Important Note

Due to unknown factors of the existing equipment, projects requiring Retro-Fit Conversions must be fully investigated by the installer.

It is the responsibility of the installer to determine if the Retro-Fit will function correctly and if additional components are required. Amico is not responsible for any additional components required.

Retro-Fit Instructions

Step 1:

Remove all secondary check parts from the existing outlets. Replace the NCG rubber seat with Amico #15 O-Ring.

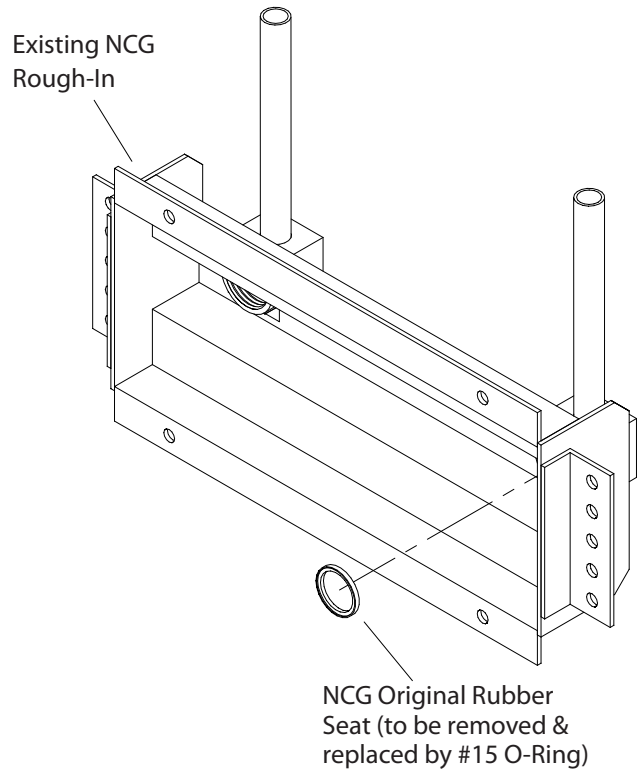

Step 2:

Thread the Amico Retro-Fit rough-in assembly to the existing NCG rough-in.

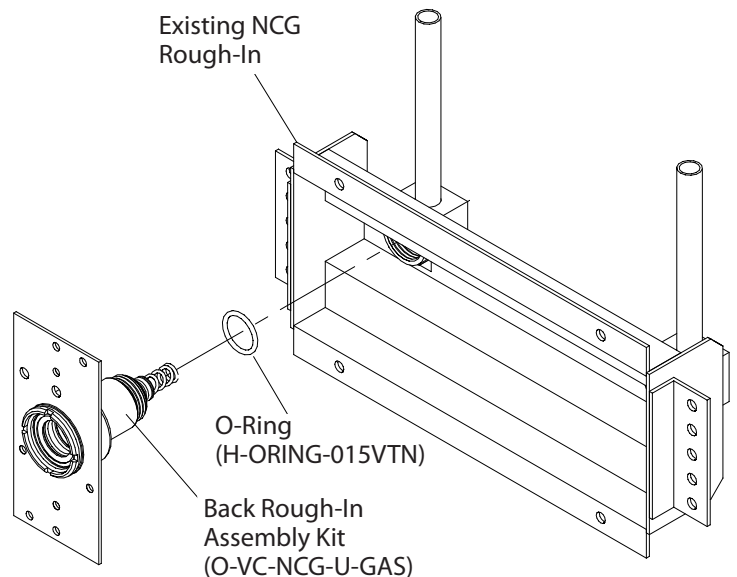
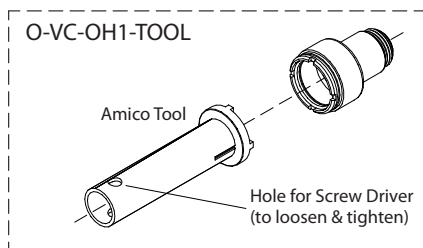

Retro-Fit Instructions

Step 3:

Use the rivet provided to attach the upgrade bracket to the existing console to ensure it is gas-specific.

Note: Ensure the Amico rough-in and the NCG rough-in are the same gas.

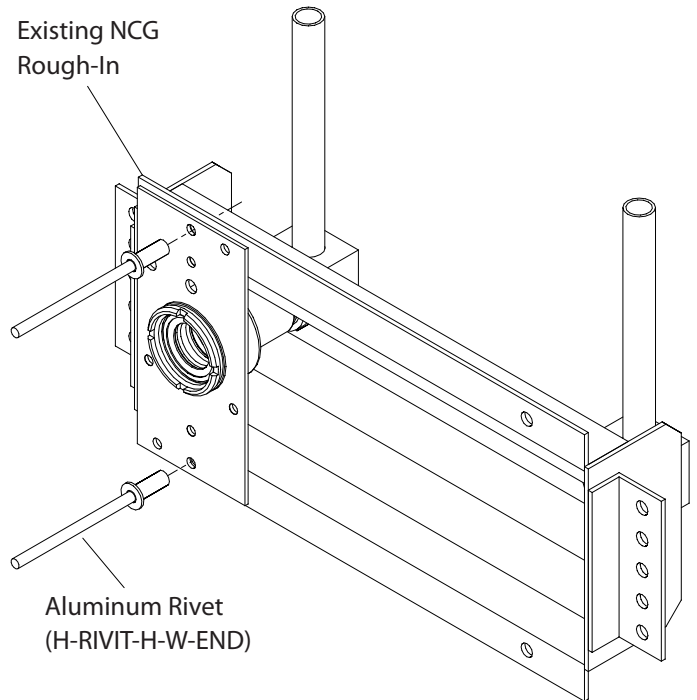

Step 4:

Place the pre-assembled filler frame and face plate over the wall outlet and insert the latch valve assembly through the face plate and fasten with the latch valve screws.

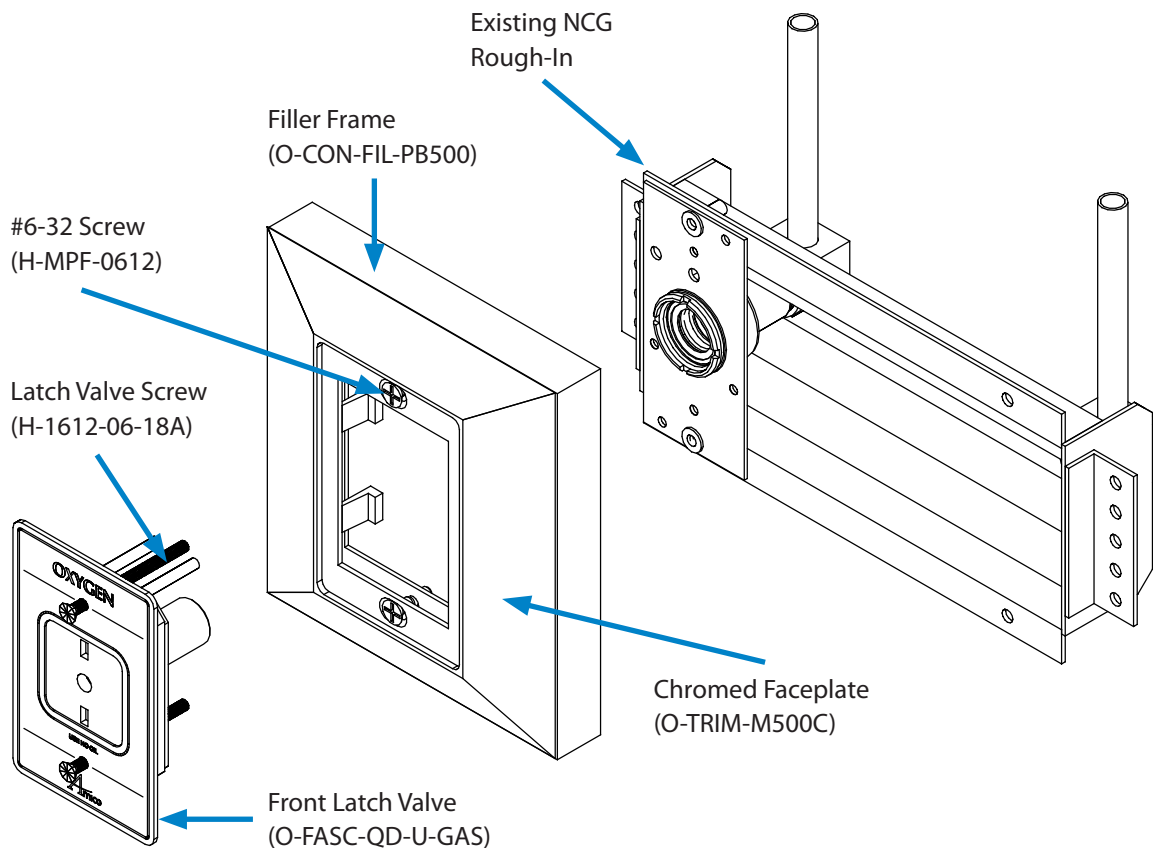

Retro-Fit Instructions

Optional:

If the latch valve is not able to engage secondary check due to wall thickness, insert brass ring into rough-in conversion barrel.

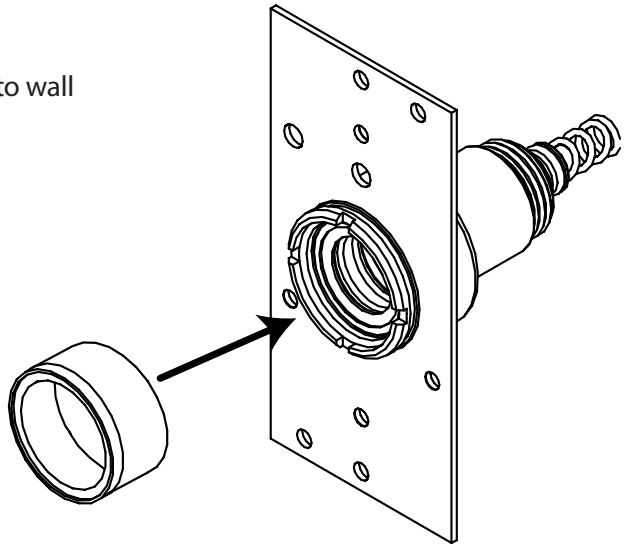

www.amico.com

Amico Corporation | www.amico.com

85 Fulton Way, Richmond Hill
Ontario, L4B 2N4, Canada

Toll Free Tel: 1.877.462.6426
Toll Free Fax: 1.866.440.4986
Tel: 905.764.0800
Fax: 905.764.0862
Email: info@amico.com