



Fully Automatic Gas Manifold

Patent US 7,013,906

Installation & Operation Manual

FOR YOUR SAFETY:

Installation and utilization of manifold and piping systems must conform to federal, state, and local specifications and regulations. The National Fire Protection Association Bulletin, NFPA #99 outlines standards for the installation and operation of medical gas systems for hospital and home care facilities. Copies can be obtained by writing National Fire Protection Association, 470 Atlantic Avenue, Boston, MA 02210.

Be certain to consult your fire marshal concerning regulations applicable to your location and particular requirements.

Read and understand these operating instructions before attempting to operate or service this equipment.

The information contained in this document is subject to change without notice

INTRODUCTION:

Information necessary to perform maintenance and service on the Ohio Medical manifold system is contained in this manual. This information is intended for use by technicians or personnel qualified to repair and service this equipment. The information contained in this document, including performance specifications, is subject to change without notice.

WARNING Personal injury or property damage can occur if you fail to follow the instructions in this manual.

WARNING Working with high-pressure gas can be hazardous. Open all valves **S-L-O-W-L-Y**. Very high temperatures and pressures, with possible damage to the equipment, will result if valves are not opened slowly.

WARNING DO NOT use a flame or “sniff” test for leaks.

WARNING Never permit oil, grease, or other combustible materials to come in contact with cylinders, manifold, and connections. Oil and grease may react with explosive force while in contact with some gases, particularly oxygen and nitrous oxide.

WARNING ALWAYS open cylinder, header, and manifold valves very slowly. When valves are opened rapidly, sudden pressurization will cause heat of recompression to occur. These temperatures and pressures can damage the manifold system and may cause injury to operator. **ALWAYS** open valves **slowly**.

WARNING DO NOT kink, twist or bend pig-tails into a radius smaller than 5 inches. If you do this, the pigtail might burst.

WARNING ALWAYS secure cylinders with racks, straps or chains. Unrestrained cylinders may fall over and damage or break off the cylinder valve.

WARNING Electrically ground oxygen and fuel gas manifolds and cylinders. Static discharges and lightning may ignite materials in an oxygen atmosphere, creating fire or explosions.

WARNING DO NOT apply heat to any part of the manifold system.

WARNING DO NOT weld near piping. Excessive heat may cause certain gases to dissociate, creating explosive force.

Table of Contents

General Operation	4
Cautions	4
Warning	4
Internal Enclosure Layout and Component Definition	6
Maintenance	9
Front Panel Layout and Operation	10
Factory Settings.....	11
Initial Start-up Procedure.....	11
Control Cabinet Optional Settings	11
Trouble Shooting	14
Cylinder Replacement	14
Warranty	21

Table of Illustrations and Diagrams

Cabinet Mounting Diagram.....	5
Electrical Hook-up Diagram.....	5
Internal Components Diagram.....	6
Process and Instrumentation Diagram	15
Internal Cabinet and Remote Alarm Wiring Schematics.....	15
Hospital Wiring Connections	16
AC Power Wiring Schematic	16
AC Power Wiring Schematic - International Model.....	17
HP Gas Manifold Piping Diagram.....	18
HP Gas Manifold Overall Dimension Diagram	18
Medical Manifold Flow Curve	18
Switch, Gauge, and DISS Quick Connect Piping Diagram.....	19
Medical Alarm Wiring Diagram	22

General Operation: Fully Automatic Medical Manifold

The fully automatic manifold is designed to switchover from the in-use bank to the reserve bank without an interruption of gas service. The fully automatic manifold will also reset the depleted bank condition to ready for use condition without operator intervention once the depleted gas supply has been replenished.

The Automatic Manifold Cabinet can be used with high-pressure (HP) cylinders on both the left and right banks or can utilize low-pressure (LP) cylinders or a Microbulk with high-pressure cylinders. This feature allows you to use one control box whether you use HP or a combination of HP and LP supply and the ability to switch gas package based on your gas considerations without the manifold becoming obsolete. (Each gas bank must have the same type of gas cylinders. Example: All HP or LP)

Also included is the ability to dictate an operating side as always primary (Prioritization is normally used when using one bank with LP cylinders or a Microbulk application). The system monitors both inlets and the delivery pressure during operation. When the switchover set point is reached, a signal is sent to the solenoid valves and the depleted supply is closed as the standby side is opened.

The LED's indicate the status of the individual banks of gas. The green LED indicates which supply bank is in use, the amber LED indicates the standby bank that is ready for use and the red LED indicates the empty bank that needs to be replenished.

The depleted bank will reset to a standby condition from empty (Automatic reset) when either side that has been replenished has a pressure that is 25% higher than the switchover set point. An empty condition occurs when either or both banks pressure equals the switchover set pressure. When first applying the right or left bank pressure to the system, it will be the in use supply.

The second bank will be shown as the standby bank. When the in use bank reaches the switchover point, the standby LED will go green and the in use bank will change from green to red indicating that bank needs to be replaced.

A leak detection system for the standby gas supply is

also included. The system stores the inlet pressure after it detects the change from empty status to standby status. If the standby supply decreases by 25% while in standby mode, a leak has been detected. The standby and empty LED's will blink to indicate the leak condition. Once the leak has been stopped, the set/reset button is pressed to clear the condition and establish the new baseline.

If an alarm condition exists, a set of relay contacts will activate the remote alarm panel of the condition and/or provide dry contact closure for any customer defined alarms to supply an alarm condition

The parameters for switchover are stored in non-volatile memory and will not change even if all power is lost to the manifold. Upon power up, the unit will return to its last state and maintain the previous switchover setting.

The manifold solenoid valves are normally open during a loss of power. The manifold will continue to operate as long as the gas supply is maintained. The internal gauges are mechanical indicators of the right and left bank gas pressure and intermediate pressure to the dual delivery regulators.

Switchover pressures can be set independently for the left and right banks. To set both at the same switchover pressure: Simply turn the "On/Off" switch to on, then move the Select Pressure Readout switch to the right, and adjust to the desired pressure for the right bank and press the "Set/Reset" button. Move the Select Pressure Readout switch to the left, press the "Set/Reset" button again and move the Configure Switchover Setting "On/OFF" switch to off. Push the Set/Reset button and the LCD panel and LED's will reinitialize with the new setting in place. (See Page 11)

CAUTION

Read and understand installation instructions thoroughly prior to using this system. If you have any questions on the installation, contact Ohio Medical (1-800-448-0770) for assistance.

WARNING

It is important that when installing components of the manifold system that no oil or contaminants come in contact with any manifold parts. If parts have been contaminated during shipment, do not use and contact Ohio Medical (1-800-448-0770) for replacement modules. If the manifold is used in a Hybrid configuration, (Low-pressure on one bank) check with the cylinder manufacturers for cylinder

withdrawal rate information. Over withdrawal of low-pressure cylinders may damage components and void warranty.

Cabinet Mounting Diagram

Attach control cabinet to wall using the four (4) tabs on box. Ensure mounting hardware is sufficient to hold 50 lbs. Types of fasteners used will depend upon wall construction.

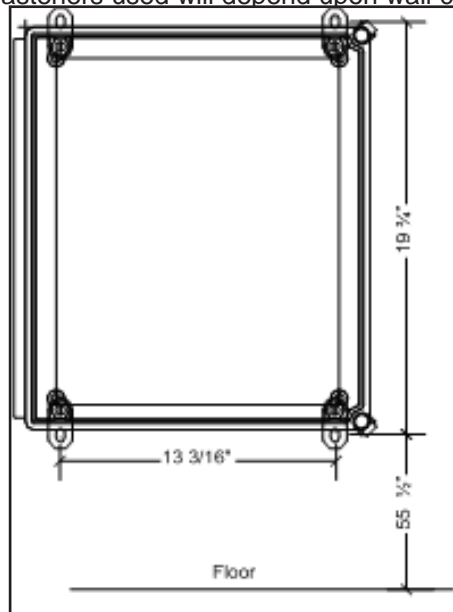

Fig.1

Electrical hookup diagram:

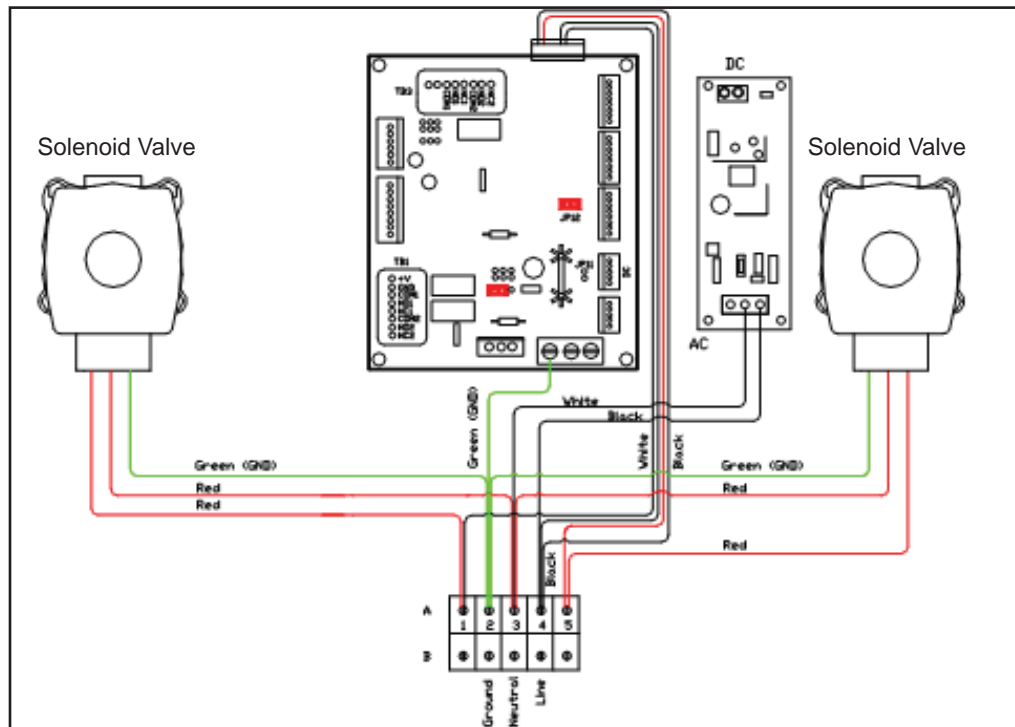

Fig.1a

See Fig. 1

AC Power Wiring:

1. Power Terminal (Item 24 on Internal Component Diagram) location B2: Safety Ground
2. Power Terminal (Item 24 on Internal Component Diagram) location B3: Neutral
3. Power Terminal (Item 24 on Internal Component Diagram) location B4: Line
4. To connect hospital alarms see the remote wiring diagrams, Fig. 9 and Fig. 10

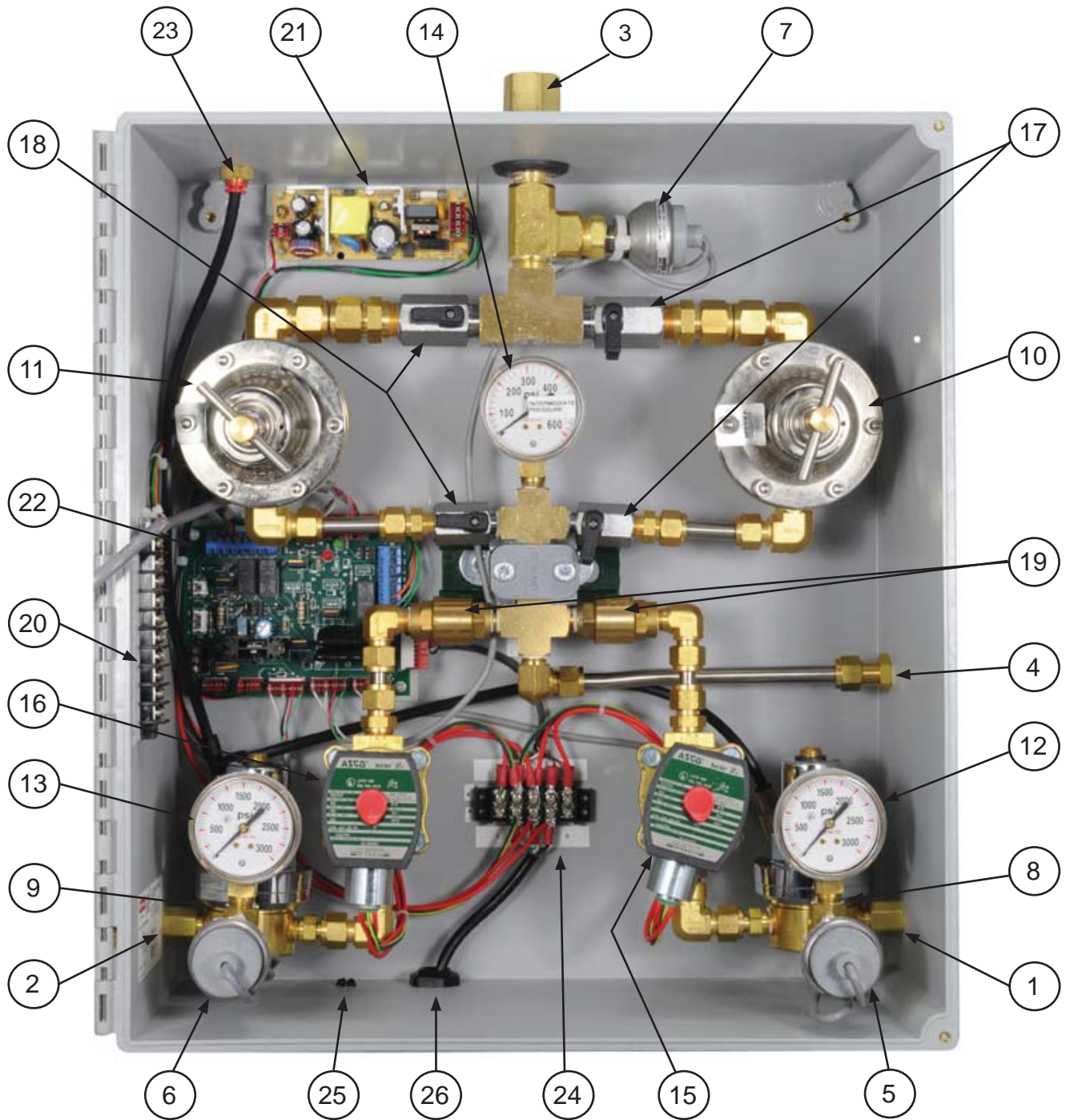

Fig. 2

Internal Components Diagram

Item	Part Number	Description
1	-	Right Bank Inlet
2	-	Left Bank Inlet
3	-	Control Cabinet Outlet
4	-	Emergency Reserve Port
5	263442	Right Bank Pressure Transducer
6	263443	Left Bank Pressure Transducer
7	263444	Delivery Pressure Transducer
8	263445	Right Bank Intermediate Pressure Regulator
9	263446	Left Bank Intermediate Pressure Regulator
10	263447	Right Delivery Regulator
11	263448	Left Delivery Regulator
12	263410	Right Bank Inlet Gauge
13	263411	Left Bank Inlet Gauge
14	263412	Intermediate Pressure Gauge
15	263413	Right Bank Solenoid Valve
16	263414	Left Bank Solenoid Valve
17	263415	Right Delivery Regulator Diverter Valves
18	263416	Left Delivery Regulator Diverter Valves
19	263417	Right and Left Side Check Valves
20	-	External Alarm Connection
21	263418	Power Supply/Transformer
22	263419	PC Relay Board
23	-	Vent Outlet
24	-	Power Terminal
25	-	Alarm Wiring Access Port
26	-	Incoming Wiring Conduit Hub
27	263449	Display Board, Front Panel (Not Shown)
28	263431	Header Bar Heater Assembly Kit (Not Shown)
29	261669	CGA-540, 36" Pigtail, Oxygen, flexible (Not Shown)
30	263080	CGA-540, 24" Pigtail, Oxygen, rigid (Not Shown)
31	261670	CGA-326, 36" Pigtail, N2O, flexible (Not Shown)
32	261671	CGA-580, 36" Pigtail, Nitrogen, flexible (Not Shown)
33	261672	CGA-346, 36" Pigtail, Med. Air, flexible (Not Shown)
34	262673	CGA-320, 36" Pigtail, CO2, flexible (Not Shown)

Internal Components List (Fig. 2)

Enclosure layout and Component definition (Fig. 2)

1. **Right Bank Inlet:** Maximum Inlet pressure: 3000 PSIG.
2. **Left Bank Inlet:** Maximum Inlet pressure: 3000 PSIG.
3. **Control Cabinet Outlet:** Variable delivery pressure.
4. **Emergency reserve port:** This inlet port is for the **regulated** high pressure reserve gas supply (**Maximum inlet of 200 psig**). This emergency supply inlet pressure will need to be set at least 20-25 psi higher than the delivery pressure from the manifold and 5 PSIG less than the manifold switchover pressure.
5. **Right Bank Pressure Transducer:** 0-3000 PSIG range. Converts right bank inlet pressure to voltage (.5VDC-5DCV signal and is displayed on the LCD screen as a PSIG readout.
6. **Left Bank Pressure Transducer:** 0-3000 psig range. Converts left bank inlet pressure to voltage (.5VDC-5DCV signal and is displayed on the LCD screen as a PSIG readout.
7. **Delivery Pressure Transducer:** 0-250 PSIG range. Converts delivery outlet inlet pressure to voltage (.5VDC-5DCV signal and is displayed on the LCD screen as a PSIG readout.
8. **Right Bank Intermediate Pressure Regulator:** Reduces inlet pressure to a preset intermediate pressure. Pressure is read on the intermediate pressure gauge (#14) when right bank is in use.
9. **Left Bank Intermediate Pressure Regulator:** Reduces inlet pressure to a preset intermediate pressure. Pressure is read on the intermediate pressure gauge (#14) when left bank is in use.
10. **Right Delivery Regulator:** This is a manual adjustment to be made with gas flowing. **Delivery pressure is shown on the LCD display** when the "Select Pressure Readout" switch is in the "Delivery" position. The internal mechanical gauge is not the manifold delivery pressure, but reads the inlet pressure to the line regulators (Intermediate Pressure from Left or Right Intermediate regulator).
11. **Left Delivery Regulator:** This is a manual adjustment to be made with gas flowing. **Delivery pressure is shown on the LCD display** when the "Select Pressure Readout" switch is in the "Delivery" position. The internal mechanical gauge is not the manifold delivery pressure, but reads the inlet pressure to the line regulators (Intermediate Pressure from Left or Right Intermediate regulator).
12. **Right Bank Inlet Gauge:** 0-3000 PSIG, 2" single scale gauge displays the right bank inlet pressure. This mechanical gauge is used to verify gas status in a non-power condition.
13. **Left Bank Inlet Gauge:** 0-3000, 2" single scale gauge displays the left bank inlet pressure. This mechanical gauge is used to verify gas status in a non-power condition.
14. **Intermediate pressure gauge:** This gauge is used to view the pressure from the active intermediate regulator supply to the delivery regulator. The active intermediate pressure regulator is the one (Left or Right) that the bank is in use (Green LED) In the case of a power outage, the active intermediate regulator becomes the one that is at a higher setting.
15. **Right Bank Normally Open Solenoid Valve:** The manifold uses Normally Open (NO) solenoids to control inlet gas supply. If power fails, these solenoids open to provide all gas available during this condition. When power is restored, normal operation will resume.
16. **Left Bank Normally Open Solenoid Valve:** The manifold uses Normally Open (NO) solenoids to control inlet gas supply. If power fails, these solenoids open to provide all gas available during this condition. When power is restored, normal operation will resume.
17. **Right Delivery Regulator Diverter Valves:** These valves are used to isolate the right delivery regulator in the event of required replacement or repair. These provide 100% backup for gas delivery to the pipeline. If one regulator should fail, changing the valves will select the other regulator thereby continuing to supply gas to the pipeline. The regulator assembly can be removed and repaired without interruption to the gas delivery to the pipeline. **In normal operations, they are normally open.**
18. **Left Delivery Regulator Diverter Valves:** These valves are used to isolate the left delivery regulator in the event of required replacement or repair. These provide 100% backup for gas delivery to the pipeline. If one regulator should fail, changing the valves will select the other regulator thereby continuing to supply gas to the pipeline. The regulator assembly can be removed and repaired without interruption to the gas delivery to the pipeline. **In normal operations, they are normally open.**

19. **Right and Left Side Check Valves:** Prevents reverse flow of gas
20. **“MTB” External Alarm Connection (Not Shown):** See Fig. 9 and Fig. 10 “Internal Cabinet and Remote Alarm Wiring Schematics” and Hospital Wiring Connections.
21. **Power Supply/Transformer:** Reduces inlet voltage (120VAC – 60 Hz) to required system voltage.
22. **PC Relay Board:** Interconnects incoming and outgoing analog signals with PC Process Board, transducers, power supply, and solenoid valves. Also provides signals and power to wiring terminal block external alarm connection terminal.
23. **Vent Outlet:** Outlet for combined intermediate vent line. (To be piped to a safe location) The end of vent line should end in a bent or hooded fashion and protected with a screen.
24. **Power Terminal:** See Fig. 11 “AC Power Wiring Illustration” for internal power wiring to solenoid valves, and relay board and NO solenoid valves.
25. **Alarm Wiring Access Port:** Additional capped port for alarm wiring.
26. **Incoming wiring conduit Hub:** For incoming wiring, 120VAC – 60 Hz.

Maintenance

1. Pressure Control Cabinet
 - a. Daily
 - i. Record delivery pressure
 - b. Monthly
 - i. Check regulators and valves for external leakage
 - ii. Check valves for proper closure
2. Manifold Header
 - a. Daily
 - i. Observe Nitrous Oxide and Carbon Dioxide systems for cylinder frosting or surface condensation. Should condensation or frosting occur it might be necessary to increase manifold capacity or add external heaters to manifold.
 - b. Monthly
 - i. Inspect valves for proper closure
 - ii. Check cylinder pigtailed for cleanliness, flexibility, wear, leakage, and thread damage. Replace damaged pigtailed immediately.
 - iii. Inspect pigtail check valves for closure
 - c. Every 4 Years
 - i. Replace pigtailed

Front Door Control Layout

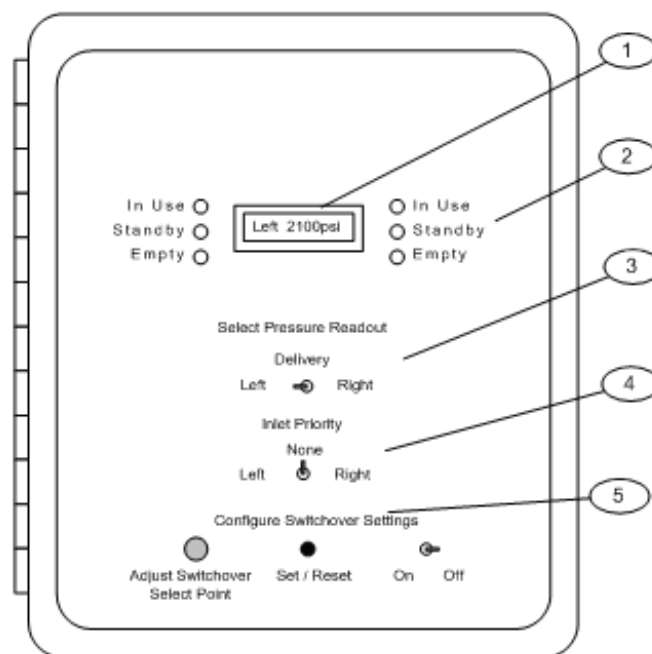

Fig. 3

1. **LCD Panel**
Used for digital read-out of right and left cylinder bank contents, pipeline delivery pressure and display switchover pressure when "calibration" is selected.
2. **System Status Lights** for each cylinder bank: Green, Amber and Red.
Green: Bank operation normal and in use.
Amber: Standby signal to signify reserve bank is full and ready for use.
Red: Signals depleted cylinder bank, requires changing out.
Leak: Amber and Red flashing indicate reserve cylinder bank leak.
3. **Select Pressure Readout Switch:** Selects LCD panel pressure readout.
Right: Right bank cylinder contents.
Left: Left bank cylinder contents.
Delivery: Pipeline delivery pressure from control cabinet.
4. **Inlet Priority Switch:** Selection of which bank has priority as the primary provider of gas.
None: Factory setting for normal operations, in this setting the primary side will alternate sides as the cylinder banks are depleted and replenished.
Left: Selects the left bank as the priority side. In this position the left bank becomes the primary or in-use supplier of gas at startup and return to primary when the cylinders on this side are changed out after being depleted.
Right: Selects the right bank as the priority primary side.
5. **Configure Switchover Setting Switches:**
On/Off: Normally in off position. Turned on when you are changing the switchover pressure settings (The pressure at which the manifold will changeover from one cylinder bank to the other).
Adjust: Used to select desired switchover pressure. **The minimum switchover setting is 70 psig.**
Set / Reset: Sets selected switchover pressure. You may have independent settings for right and left bank. Reset also clears leak mode condition.

Factory Settings: Manifold control cabinet is factory preset for switchover pressures (the point of cylinder pressure when the manifold will switch from the in-use cylinder bank to the reserve) listed below: **The minimum switchover setting is 70 psi.**

<u>Manifold Delivery Pressure:</u>	<u>Switchover Setting:</u>
50-55 PSIG range	105 PSIG
160-185 PSIG range	250 PSIG

Manifold control switches to be in the factory preset default position as follows: (Verify default positions of panel switches, then proceed to step 1.)

Select Pressure Readout:	Delivery
Inlet Gas Priority Select:	None
Configure Switchover Settings:	Off

Initial Start-up Procedure:

- After applying main power to the control cabinet, left and right empty (Red) LED's will be on.
- Inspect all cylinder connections for dirt, oil or other contamination. If any is found, clean or remove from service and replace.
- Slowly allow gas from the first bank to pressurize system. This will change the gas system status LED on that side to In-use (Green)
- Slowly allow gas from second bank to pressurize system. This will change the gas system status LED on the second side to Standby (Amber)
- Press the "Set" button and release, Fig. 4 (B) to complete the initialization.**
- After verifying all connections, slowly adjust the delivery regulators to your desired pipeline pressure allowing the pipeline to fill. With gas flowing, adjust right and left regulators clockwise to increase pressure and counter-clockwise to decrease pressure. (Each regulator must be isolated from the other regulator using the appropriate diverter valves while making this adjustment). The delivery pressure setting of the regulator being adjusted will be displayed on the LCD panel with the Select Pressure Readout switch in the "Delivery" mode.
- With the Inlet Priority switch set in "None" mode, (Factory setting) the bank with the green indicator light will be the in-use cylinder bank. The opposite cylinder bank (amber light on) will start-off as the reserve bank. The cylinder banks will alternate between in-use and standby reserve as each bank is depleted and replenished with new cylinders.

Control Cabinet Optional Settings

The manifold control switchover pressure can be tailored to your requirements. Both cylinder banks can be set to switchover at the same setting or each cylinder bank can be set to switch over at two independent settings. **The minimum switchover setting is 70 psi.**

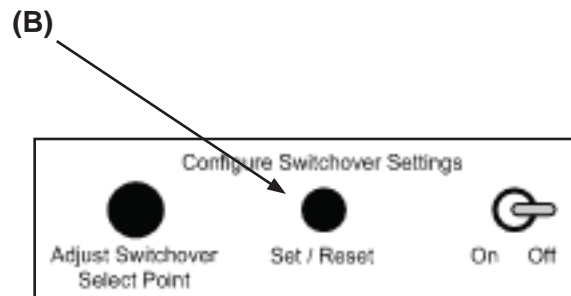

Fig. 4

Changing the switchover pressure settings from factory settings

NOTE: The inlet pressure on the empty bank must change 25% above the switchover setting to cause the status to change from an empty condition to the standby condition, i.e., a switchover setting of 100 psi will cause an "Empty" condition when the inlet is 100 psi. When the inlet pressure is 125 psi or more, the status will change to "Standby" condition (If "Inlet Priority" Switch is in "None" mode), or will change to the In-use condition (If "Inlet Priority" Switch is in right or left bank position as it relates to the bank being replenished)

- Press "Set" (**Fig. 4 (B)**) button firmly and release.

NOTE: The "delivery" position of "Select Pressure" switch **IS NOT** used for calibration. **IT WILL DISPLAY PRESSURE, BUT WILL NOT AFFECT CALIBRATION. USE THE RIGHT AND LEFT POSITIONS TO SET THE SWITCHOVER PRESSURE AS DEFINED IN THE FOLLOWING STEPS.**

2. Set "ON/Off" switch to "ON", **Fig. 5 (A)**. (Red & green LED's will flash for a short while).
3. On the **Pressure Readout** switch, **Fig. 5 (E)**, select right bank.
4. Looking at the LCD Display, **Fig. 5 (D)**, adjust the desired switchover pressure set point by turning the Adjust Switchover Select Point" knob **Fig.5 (C)**. Turn clockwise to increase the switchover pressure setting or counter clockwise to decrease the switchover pressure setting (Value will display in increments of 12 PSIG).
5. Once you have verified the desired switchover pressure setting on the LCD Display, **Fig. 5 (D)**, press the "Set / Reset" button, **Fig. 5 (B)** and release. This stores the switchover pressure for the Right Bank.
6. Move the Select "Pressure Readout" switch to the left position. Verify the setting on the LCD panel, **Fig. 5 (D)**, or adjust **Fig. 5 (C)** to desired switchover pressure setting.
7. Once you have verified the desired setting, **Fig. 5 (D)**, press the "Set / Reset" button, **Fig. 5 (B)** and release.
8. Both right and left switchover pressure set points are now stored in memory.
9. Set the **Configure Switchover Setting** "ON/Off" switch to off, **Fig. 5 (A)**. (LED's will stop flashing & go back to normal operation).
10. Press the Configure Switchover Settings "Set / Reset" button and release. **Fig 5 (B)**.
11. Move the **Select Pressure Readout** switch to which pressure reading you choose to display (Left Bank, Delivery, or Right Bank pressure).

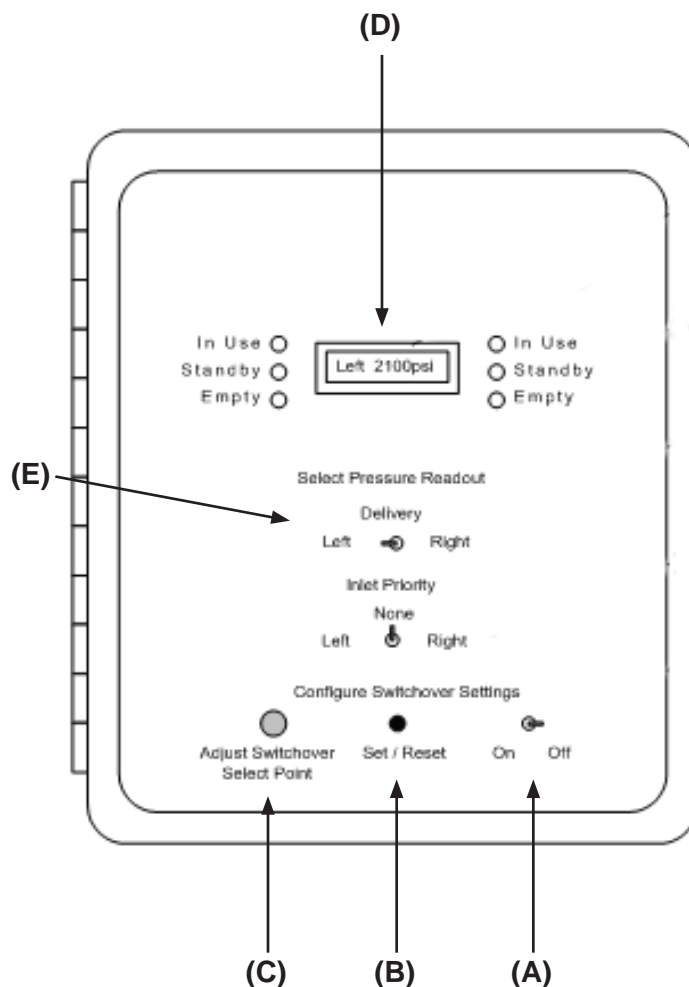

Fig. 5: Cabinet Controls

Changing Inlet Priority Select Settings

The Manifold control cabinet gives you the option of setting the "Inlet Priority". This function tells the controls which side will take priority in supplying the inlet gas to the control cabinet.

None: This is the factory setting. In this setting the primary (in-use) cylinder bank and the standby cylinder bank will alternate as the in-use cylinders. As cylinders are depleted on one side (That cylinder bank status light will change from green to red) the manifold will switchover and use the gas from the standby reserve (This cylinder bank status light will change from amber to green). Once you change the depleted cylinders, they will automatically go to standby reserve mode. (Status light will change from red to amber).

Left Bank: In this selected mode, the left cylinder bank will take priority over the right cylinder bank to supply inlet gas to the control cabinet. The left bank will resume this priority after the left cylinder bank is depleted and has been replenished with new cylinders. The Right Bank will be the control cabinet inlet gas supply only when the left cylinder bank is empty. Once the left bank cylinders have been replaced, the right cylinder bank will resume its standby reserve mode.

Note: In this mode, it is possible to eventually deplete the reserve supply over time.

Right Bank: In this selected mode, the right cylinder bank will take priority over the left cylinder bank to supply inlet gas to the control cabinet. The right cylinder bank will resume this priority after the right cylinder bank is depleted and has been replenished with new cylinders. The left cylinder bank will be the control cabinet inlet gas supply only when the right cylinder bank is empty.

Note: In this mode, it is possible to eventually deplete the reserve supply over time.

Leak Detection

The manifold control cabinet automatically detects a leak on the standby cylinder bank if it decreases 25% from the initial standby pressure. When this occurs, the standby status light (amber) and the empty status light (red) will blink indicating the leak has been detected. The display will show the pressure that was initially on the standby side. The manifold will continue to operate, but the leak has to be cleared to have the display return to normal operation. Once

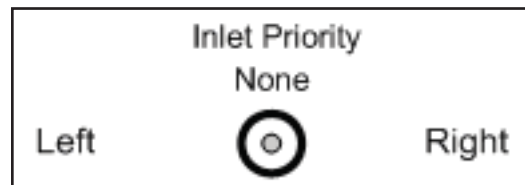

Center Position

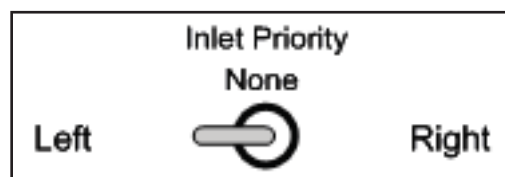

Left Position

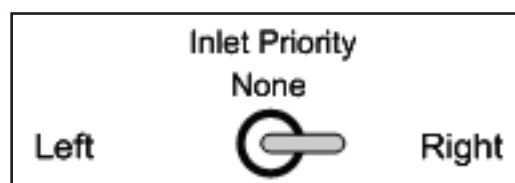

Right Position

Fig. 6

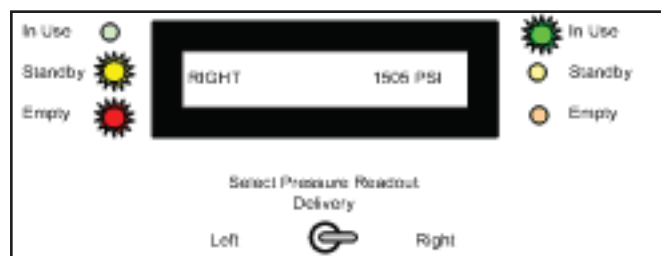

Fig. 7

you have corrected the leak, re-pressurize and push the Switchover Pressure Select "Set" button to reset the leak detection system. Note: The standby leak detection system is only operative above the cylinder bank switchover pressure set point.

Note: If the leak indication is not cleared and the status changes to "In Use", ALL three status lights may be on. Check the "in use" bank for leaks. To reset the leak detection, press the Configure Switchover Settings "Set / Reset" button and release.

Troubleshooting:

Symptom	Comments	Action
Three status lights on left or right bank	Leak detected in "Standby" condition and not cleared before this bank changed to "In Use"	Find leaks and stop them. Press "Set / Reset" button on front panel to clear condition.
No lights on front panel	Switchover "on/Off" switch has been left in the "ON" position.	Turn the switch to the "OFF" position and press the "SET" switch.
Display reads, "ERROR Right, left, or Delivery" with the switchover switch in the off position.	This is a built in diagnostic that checks the inlet and delivery transducer sensor.	Re-calibrate the switchover pressure for the inlets. If display still shows "error", the faulty sensor needs to be replaced
Switchover occurs at a pressure that is not desired	Need to recalibrate the switchover pressure settings	Go to the Changing switchover pressure settings section and calibrate settings.
Display doesn't have the expected pressure readout	Leak on the standby bank has been detected and has not been cleared.	Press the switchover pressure select "Set" button to reset the system
No lights on the front panel and the relay board. (Located inside the enclosure).	Power is off.	Restore the AC power. Green light on the relay board will light. If problem isn't solved, call for technical service and maintain the gas supply to the right and left bank. The manifold will maintain flow until repairs are made.

Cylinder Replacement

WARNING: Never permit oil, grease or other combustible material to come in contact with cylinders, manifolds and connections. Oil and grease may react with explosive force in the presence of some gases, particularly oxygen and nitrous oxide, resulting in damage to the equipment and possible injury to nearby personnel. Keep tools and equipment clean. Valves **MUST** to opened **slowly**. Pigtails must never be kinked, twisted, or bent into a radius of smaller than 5 inches. Do not apply heat to any part of the manifold or cylinders. Close pipeline shut-off valve in emergency only.

1. Turn off all valves on depleted cylinders.
2. Slowly loosen and then remove the pigtail connections from the depleted cylinders.
3. Remove the depleted cylinders and reinstall protective caps.

4. Secure full cylinders in place using chains, belts or cylinder stands. Refer to Compressed Gas Association Pamphlet P-1 for more information.
5. Remove the protective caps from full replacement cylinders. **DO NOT** stand in front of the cylinder valve outlet. **Slowly** open and quickly close (cracking) each valve slightly to blow any dirt or contaminants which may have become lodged in the cylinder valve.
6. Connect the manifold pigtails to the cylinder valves and tighten with a wrench. **Slowly** open cylinder valve farthest from the manifold. Wait 60 seconds. **Slowly** open the remaining cylinder valves. Use an approved liquid leak detector solution to locate leaks.
7. The red light on the manifold should go out and the green light should come on.
8. The bank has not been replenished and is now in reserve.

Process and Instrumentation Diagram (P&ID):
Typical of High-Pressure Medical Series with a delivery ranges of 50-55psi. & 160-185 psi

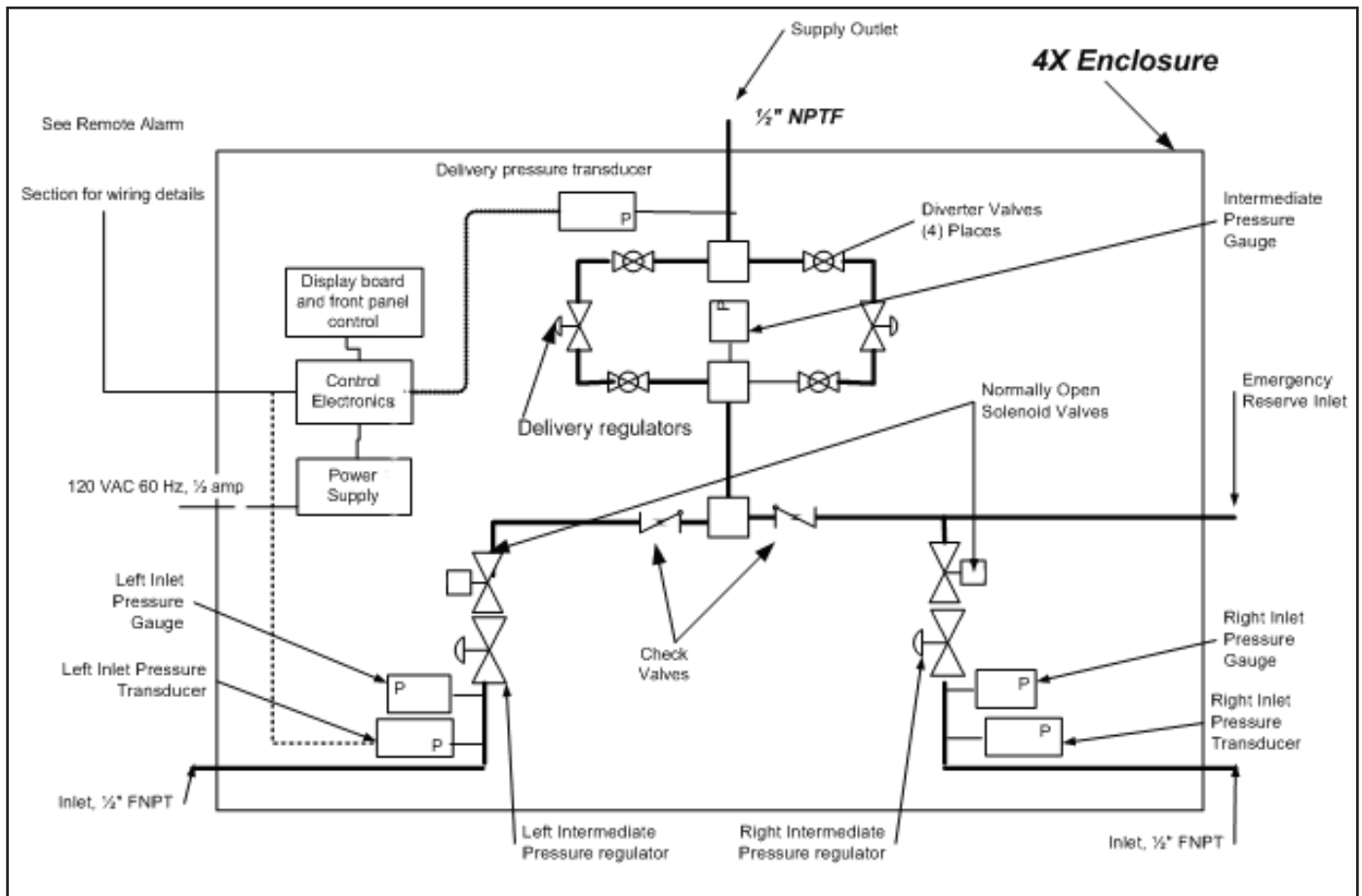

Fig. 8: Internal Cabinet and Remote Alarm Wiring Schematics

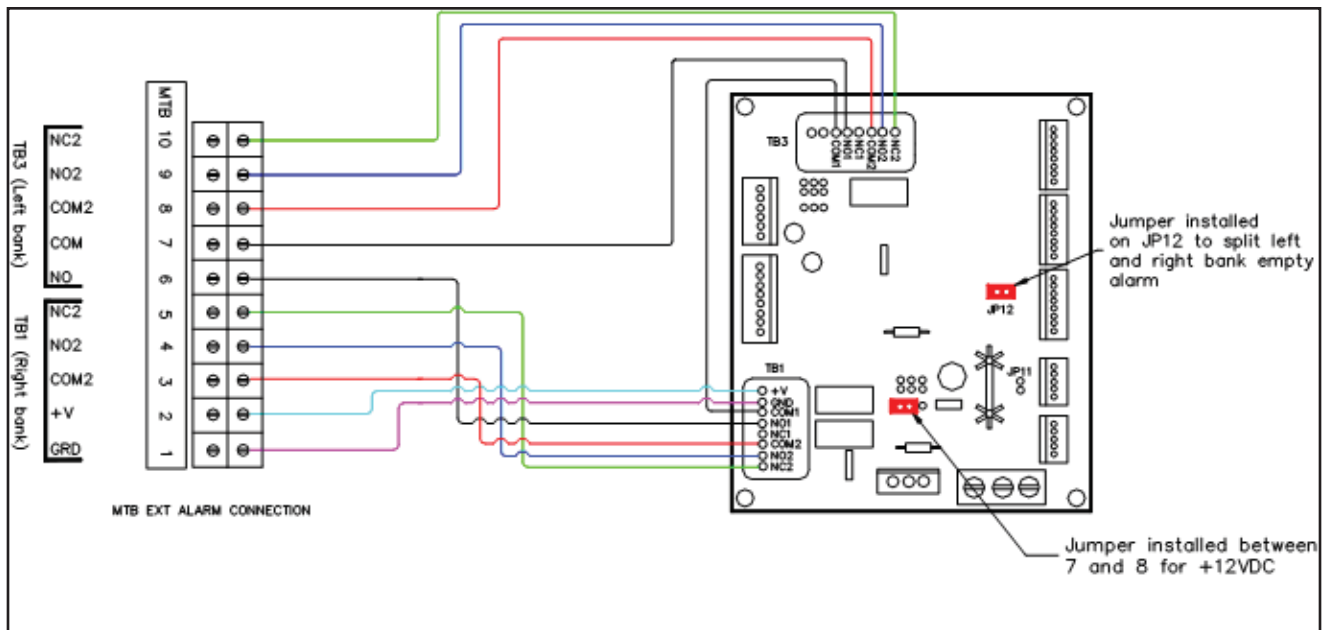

Fig. 9: Internal wiring from PC Relay Board to External Alarm Connection Terminal Strip

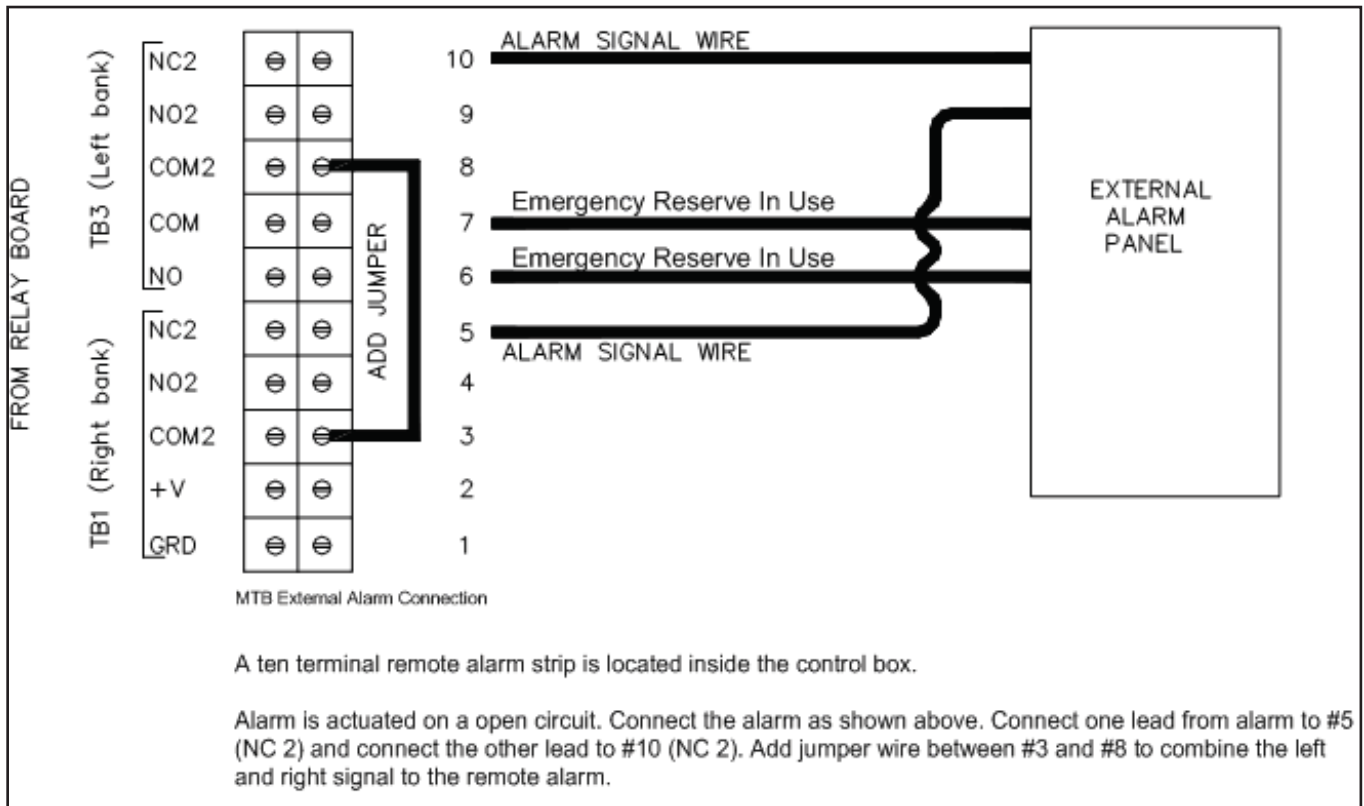

Fig. 10: Hospital Wiring Connections

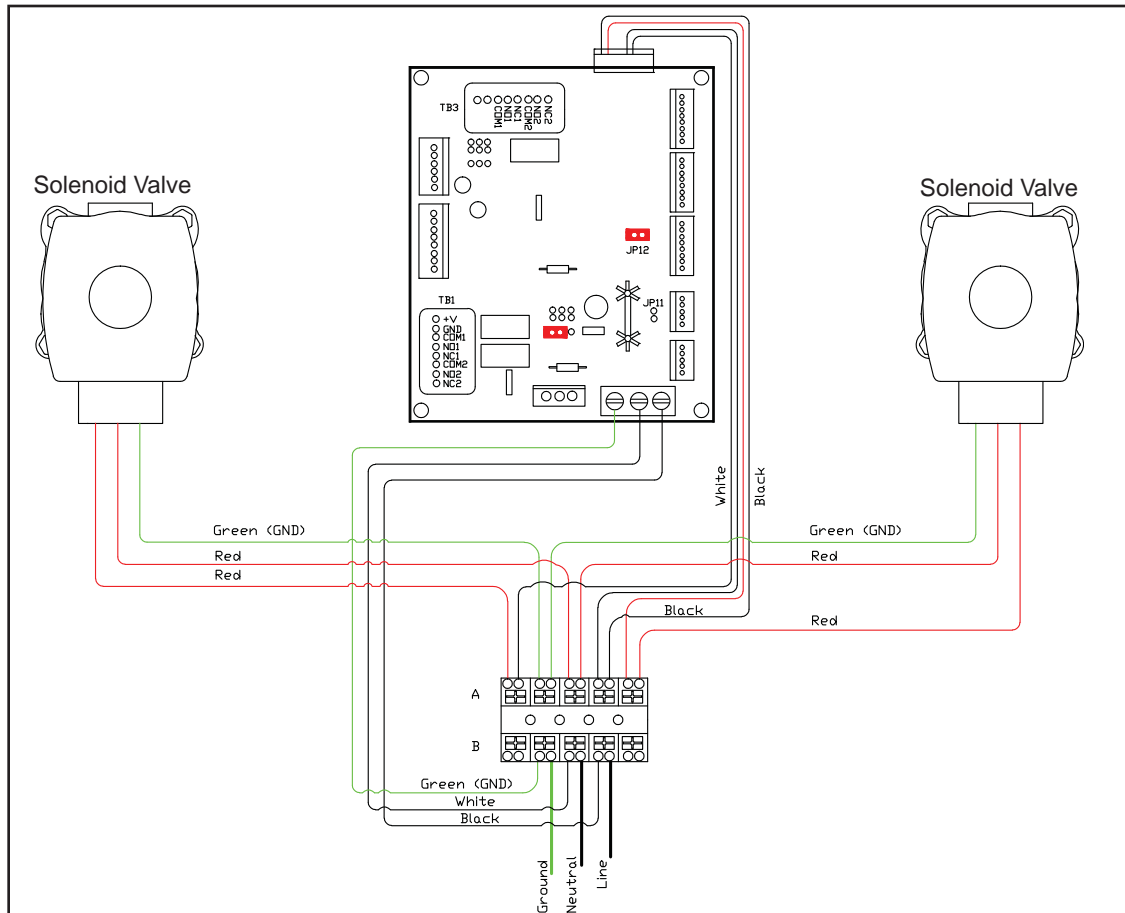

Fig.11: AC Power Wiring

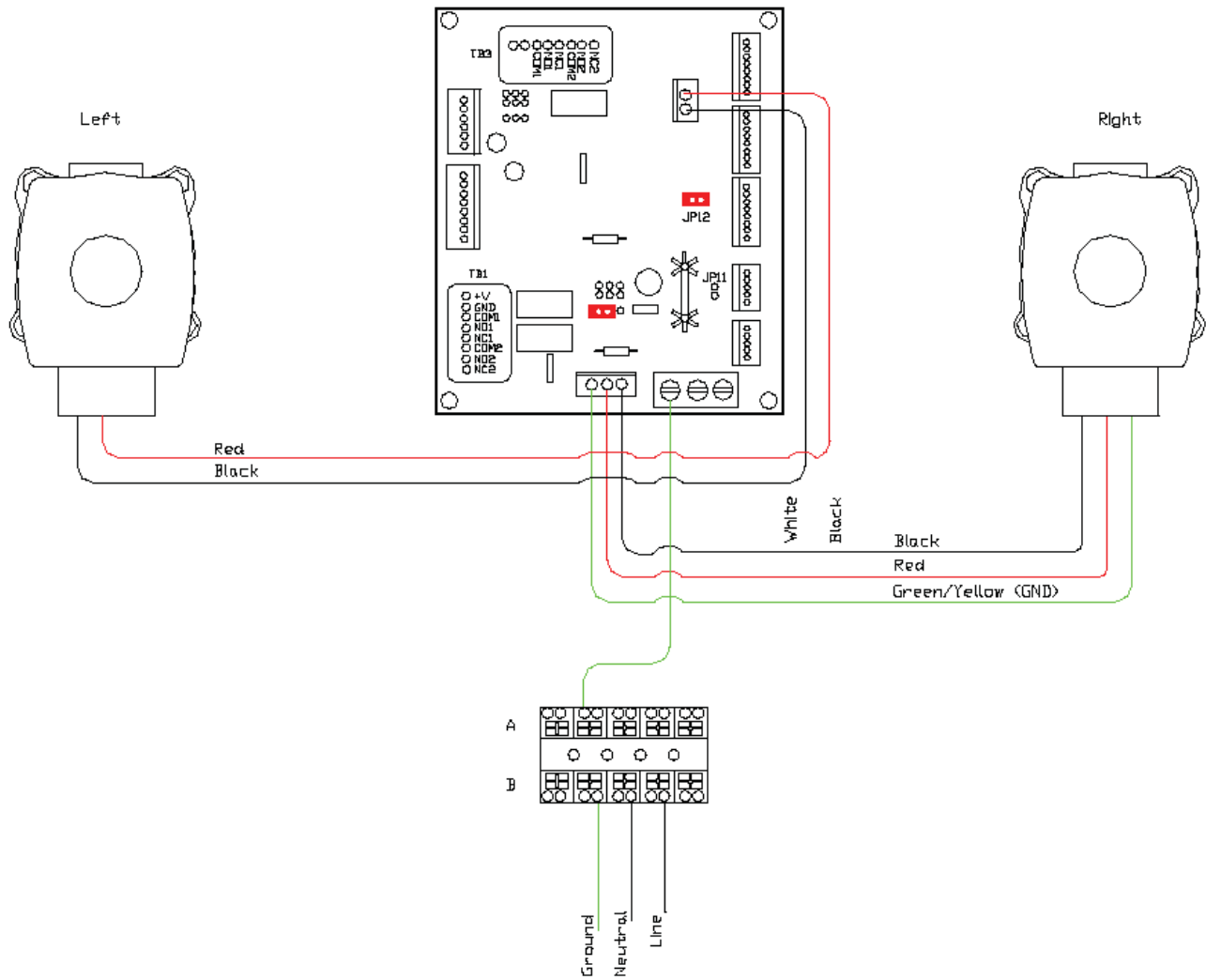
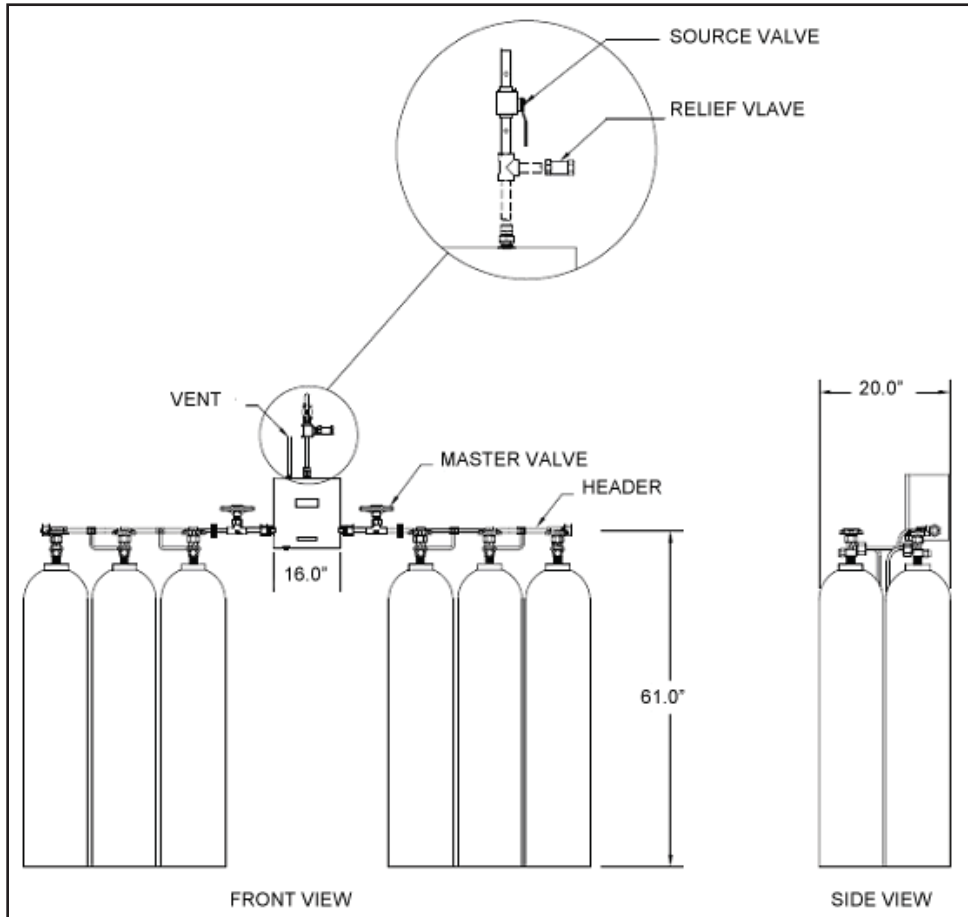

Fig.11A: AC Power Wiring - International Model



Vent Line Sizing for Relief Valves		
Pipe Size	Length of Run In*	
	Feet	Meters
1/2"	37	11
3/4"	191	58
1"	755	230
1-1/4"	2189	667
1-1/2"	4992	1522

*Pipe lengths are for straight runs in these nominal sizes. Multiply lengths by 0.75 to allow for fittings.

Fig. 12: HP Gas Manifold Diagram
NOTE: MANIFOLD WITHOUT HEATER SHOWN

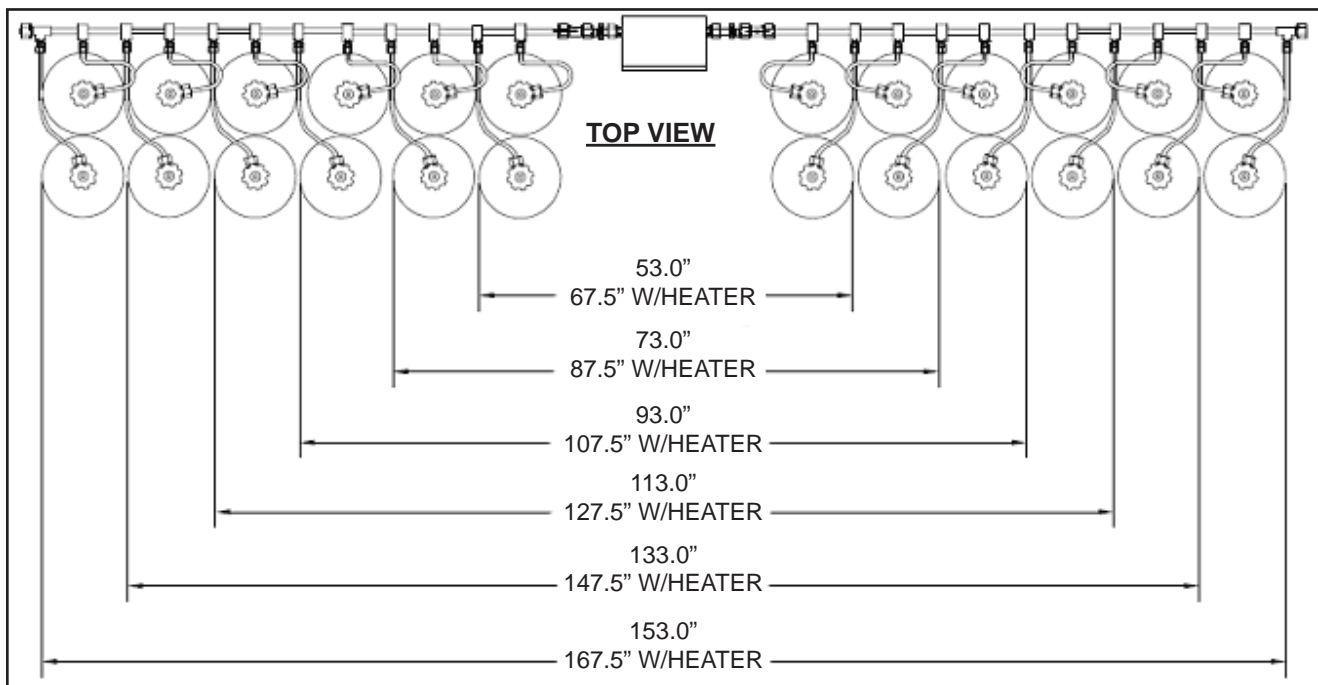

Fig. 13: HP Gas Manifold Dimensions
NOTE: MANIFOLD WITHOUT HEATER SHOWN

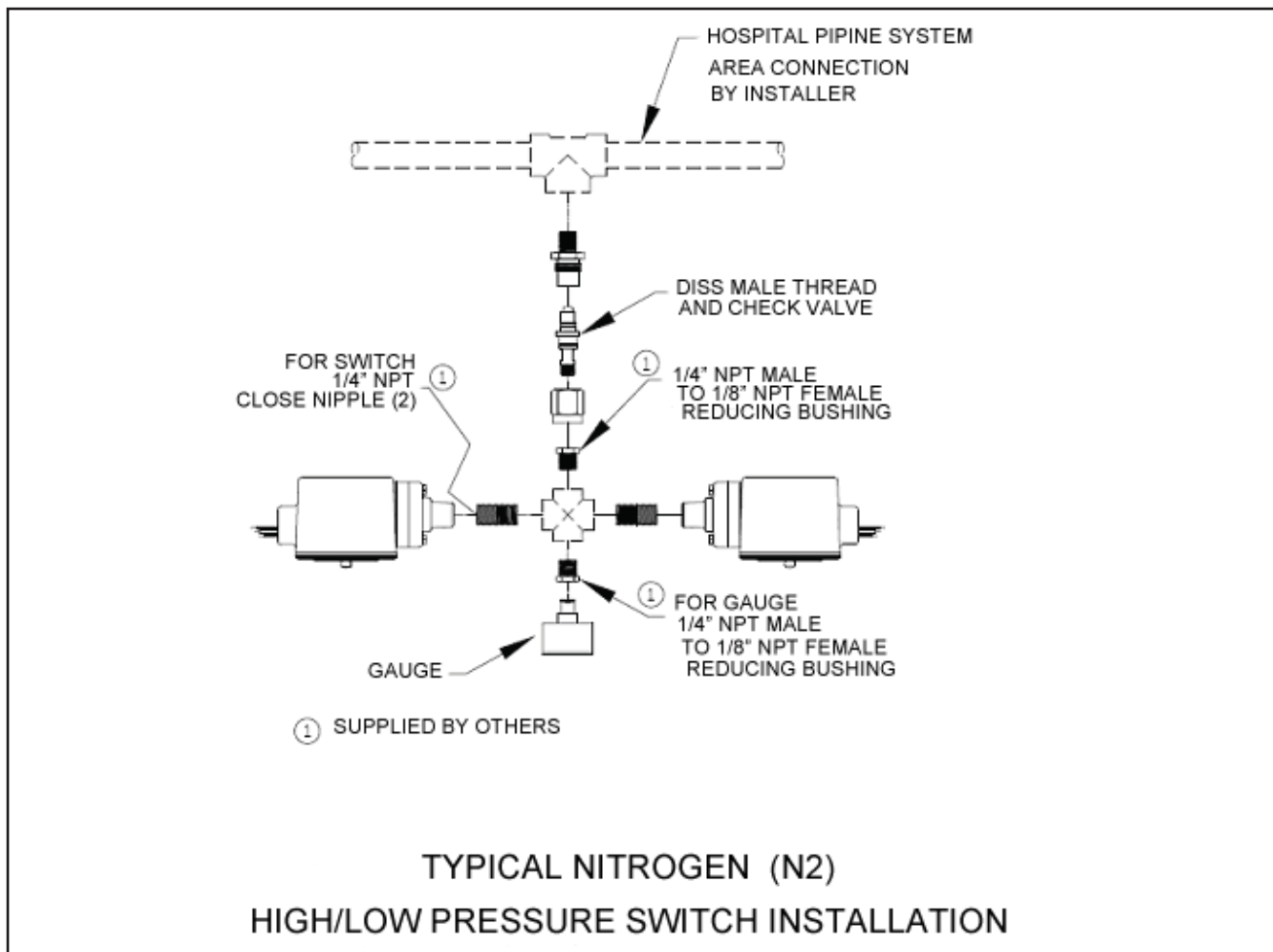

Fig. 14

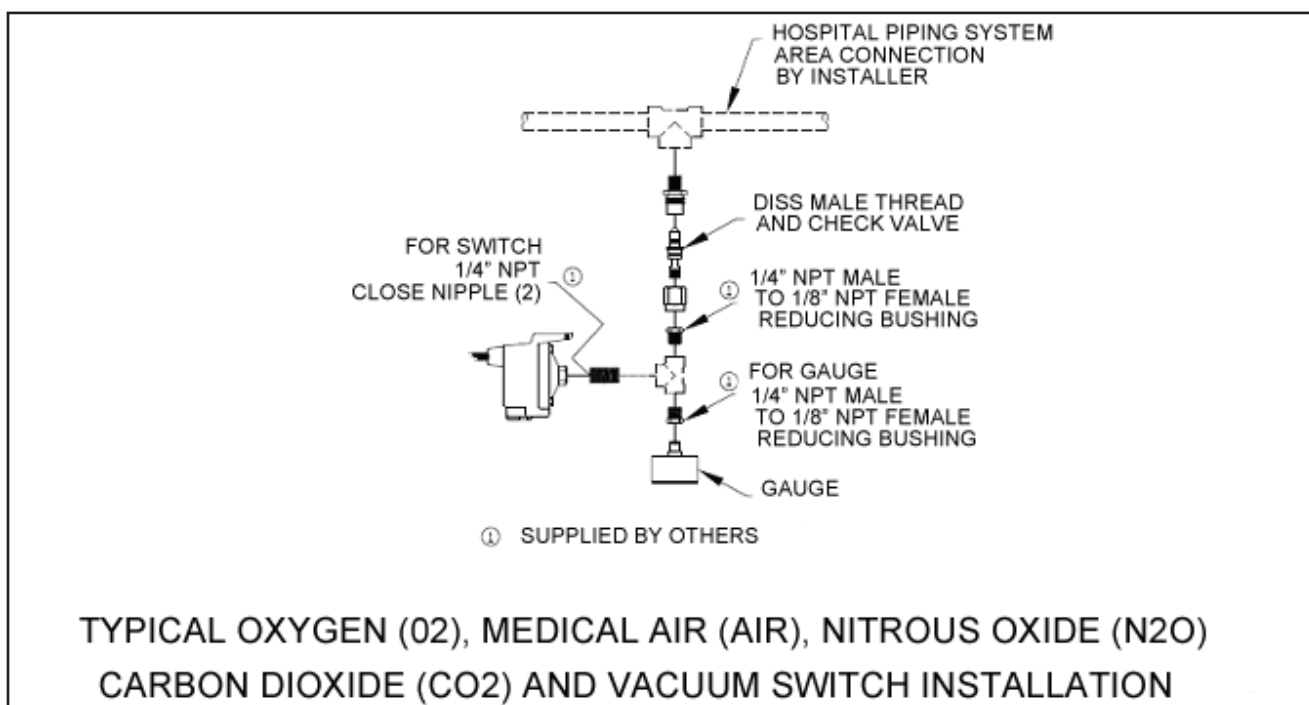

Fig. 15

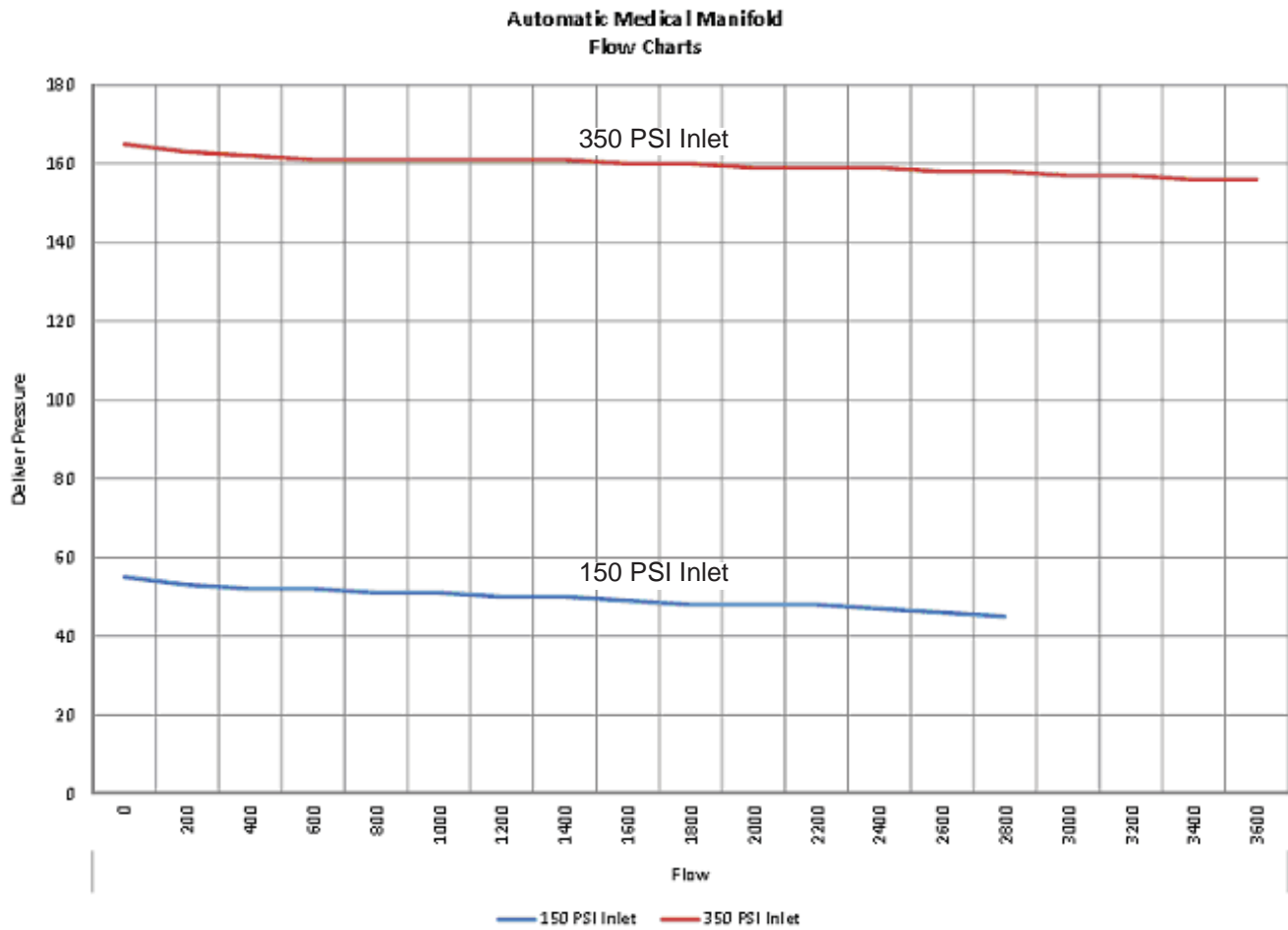
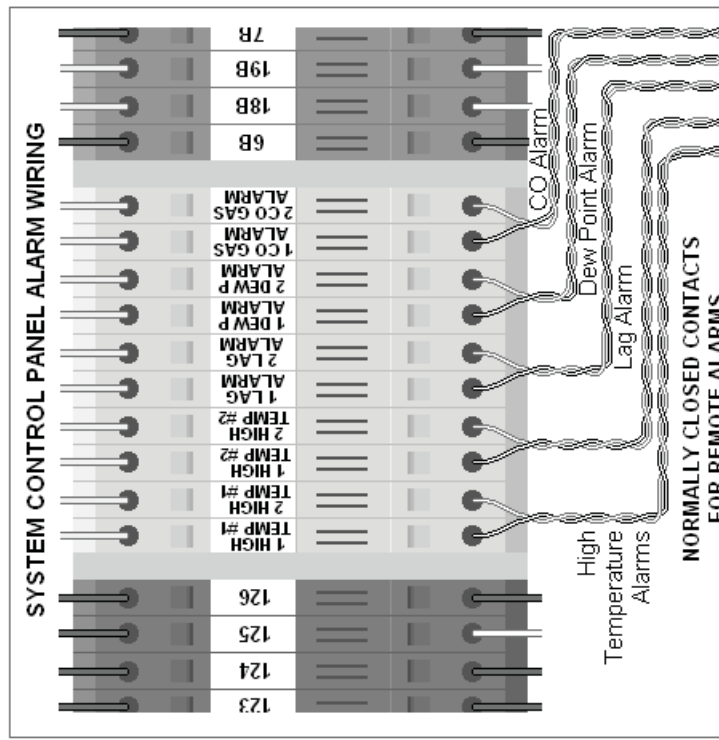
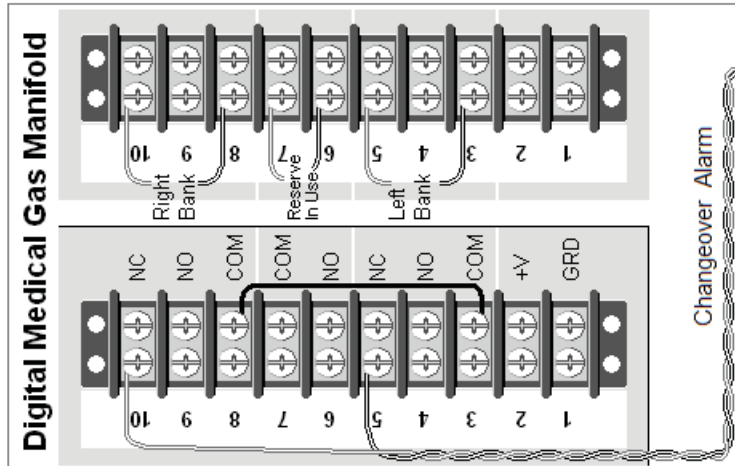
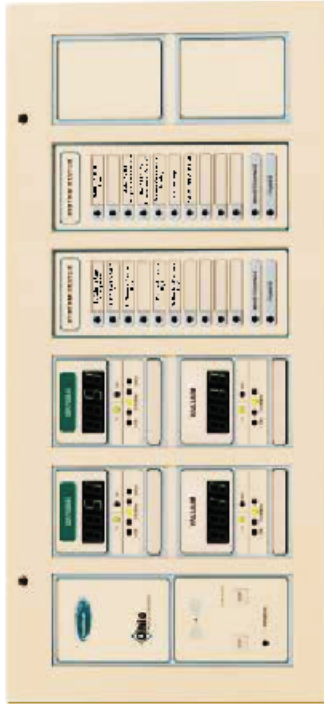

Fig. 16

**OHIO MEDICAL CORPORATION
MEDICAL GAS PIPELINE EQUIPMENT LIMITED WARRANTY**

1. **OHIO MEDICAL CORPORATION** warrants the **Medical Gas Pipeline Equipment** to be free from functional defects in material and workmanship for a period of twenty-four (24) months from the date of shipment or twelve (12) months from the date of start-up, whichever occurs first. Within said period Ohio Medical Corporation will repair or replace any part or component which is proven to be defective in either material or workmanship.
2. Ohio Medical Corporation shall warrant to the original purchaser the Medical Gas Pipeline Equipment to be free from defects in material for an additional (48) months from the date of shipment. During this period Ohio Medical will replace any parts that are proven to be defective, at no additional charge. The cost of shipping and installation shall be covered by the purchaser.
3. To obtain service within the warranty period, first contact the Ohio Medical Service Department.
4. Ohio Medical Corporation's responsibility under this warranty shall be limited to providing at Ohio Medical Corporation's sole discretion, new or replacement parts to replace any component found to be defective within the warranty period. Installation of user replaceable items will be the user's responsibility.
5. Labor to repair any part or component proved to be defective within the warranty period will be provided at no charge for any item returned to our factory adequately packaged and insured with shipping costs prepaid. Standard surface freight shipping cost to return the repaired part or component to the user will be paid by Ohio Medical Corporation.
 - a. Before returning any part or component to the factory for warranty consideration, proper return authorization, and Warranty Claim Form must first be obtained from Ohio Medical Service Department. A Purchase Order must be supplied by the claimant in the event that repairs or products returned for warranty consideration are determined to be of a Non-Warranty status.
 - b. The user will be required to issue a purchase order for replacement items. Upon receipt of the defective items, Ohio Medical Corporation will issue a credit to the user in the amount equal to the purchase order.
6. This warranty is valid only when the product has been properly installed according to Ohio Medical Corporation specifications, used in a normal manner and serviced according to factory recommendations. The warranty does not cover failures due to damage which occurs in shipment or failures which result from accidents, misuse, abuse, neglect, mishandling, alteration, misapplication or damage that may be attributable to acts of God.
7. Ohio Medical Corporation shall not be liable for incidental or consequential damages resulting from the use of this product. There are no expressed or implied warranties which extend beyond the warranties set forth above. Ohio Medical Corporation makes no warranty of merchantability or fitness for a particular purpose to equipment and to its parts and components.
8. **THE CONDITIONS OF THE BUYER'S RESPONSIBILITY ARE:**
 - a. The equipment is stored properly before installation;
 - b. The equipment is installed according to Ohio Medical Corporation's specifications and installation procedures;
 - c. The equipment is properly maintained and not altered unless by an authorized representative of Ohio Medical Corporation.

MEDICAL ALARM PANEL WIRING



NORMALLY CLOSED CONTACTS FOR REMOTE ALARMS

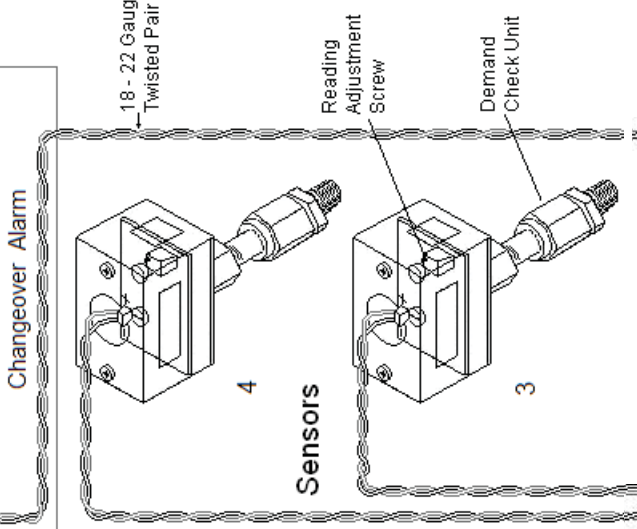
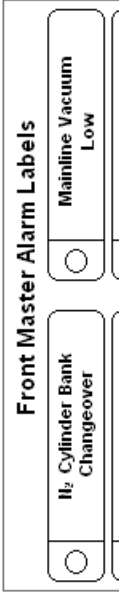
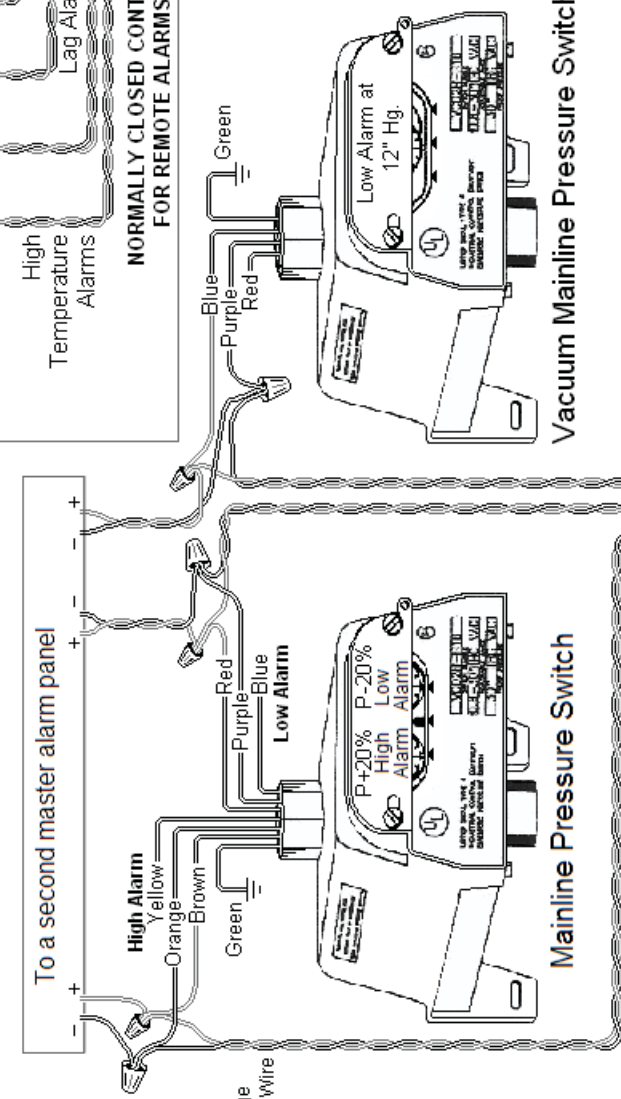

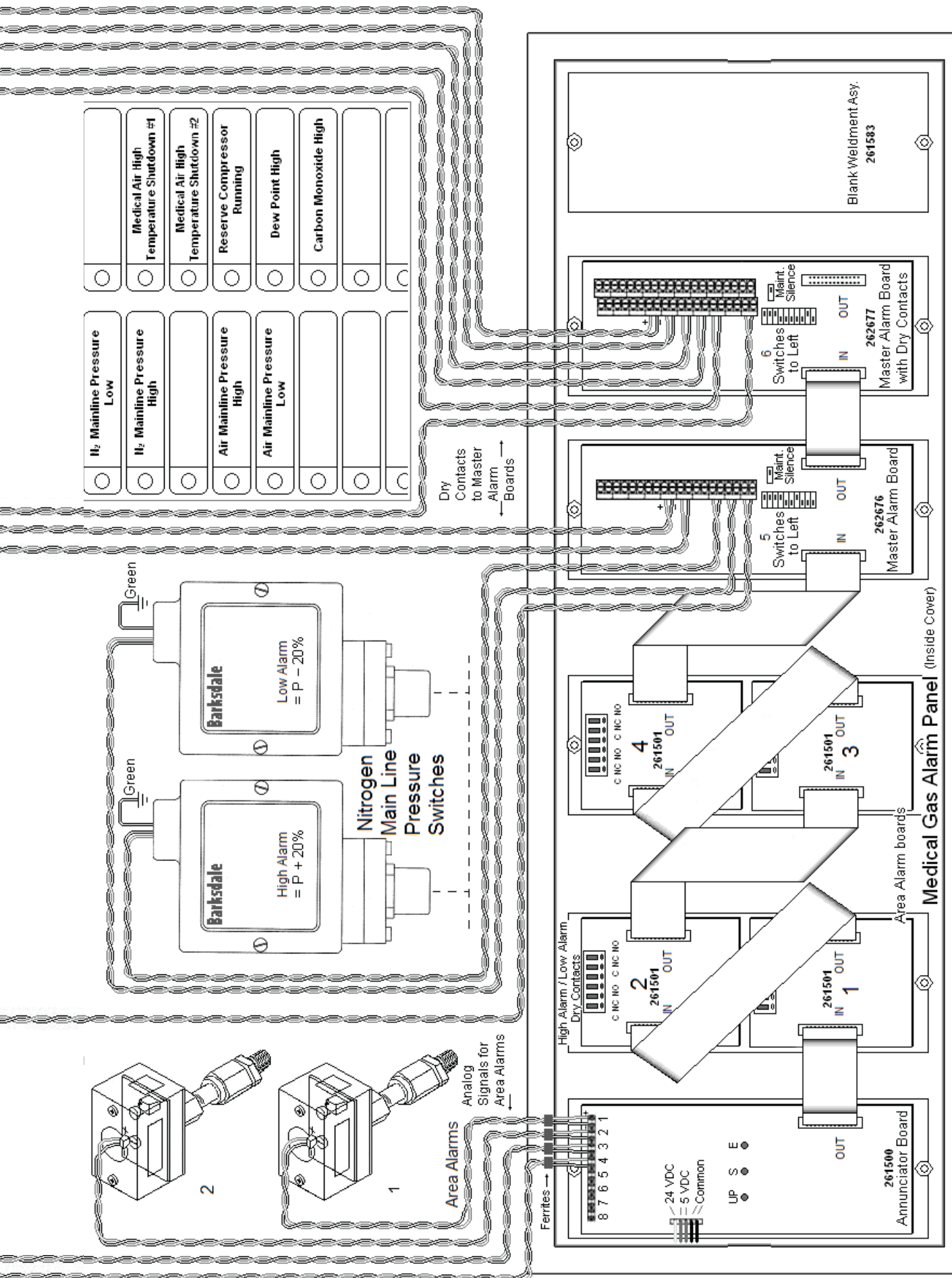



Ohio Medical Corporation
1111 Lakeside Drive, Gurnee, IL 60031-4999
Phone: 1-800-448-0770 - Fax: 847-855-6300
www.ohiomedical.com

P/N 255491 (Rev.1) 11/2009