

Pressure Switch with Gauge for Vacuum or WAGD



Features:

- Removable copper diaphragm capsule
- Instrument quality snap-action switch
- Normally open or normally closed contacts
- Nema 4 water-tight housing with mounting brackets
- Vacuum switches for normal 12" Hg systems
- Vacuum gauge with 2" dial
- DISS gas specific nut, nipple and demand check

General Specifications:

Pressure Switch with Gauge Assembly for the medical gas alarm system shall incorporate a U.L. Listed single pole double throw snap-action micro switch. The pressure switch shall be prewired with three color coded leads. Normally open or normally closed circuitry shall be field-selected to be compatible with the medical gas alarm system design. Electrical rating shall be 10 amperes at 120 volt AC.

The vacuum switch shall be tested up to 30" Hg with an adjustable range of .8" to 29" Hg, preset at 12" Hg for the alarm condition.

The switch enclosure shall be a Nema 4 water tight housing with mounting bracket, 1/4" FNPT bottom inlet gas service line connection, and 3/4" FNPT top inlet conduit.

A gauge shall be incorporated after the pressure switch. A gas specific DISS nut and nipple shall be attached to the bottom of the gauge.

The Pressure Switch with Gauge Assembly will then be mounted directly to a gas specific DISS demand check (provided by Amico) directly onto the pipeline. The demand check shall have a 1/4" Male NPT connection.

Technical Specifications

Switch Adjustment

Vacuum

Turn adjustment screw counter-clockwise to approach atmospheric pressure.

Inch
[mm]

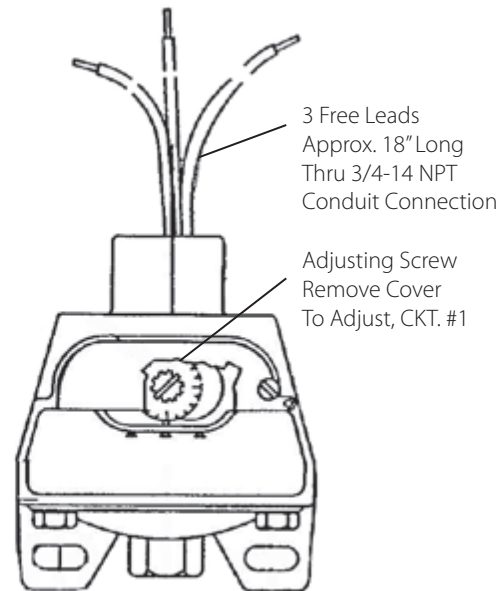
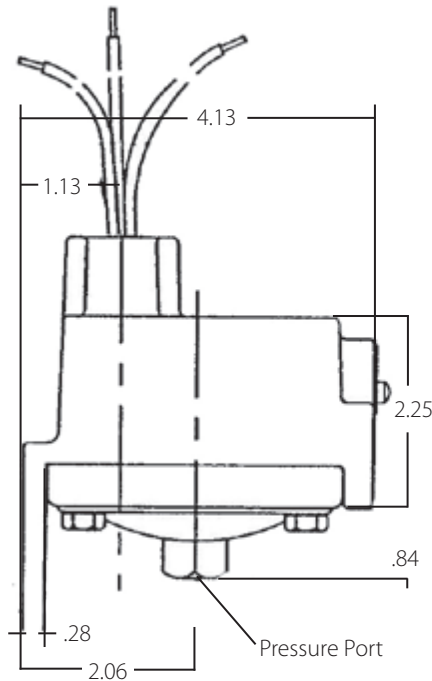

Wire Coding

Wiring Coding Vacuum

Ground - Green

Common - Purple

Normally Closed -Red

Normally Open -Blue

Model Numbers

P-PRSW-GA-VAC = Vacuum Gauge Assembly

P-PRSW-GA-WAGD = WAGD Gauge Assembly