

# ROTARY VANE - DRY DUPLEX TANK MOUNTED VACUUM SYSTEM (1.2 HP - 8.9 HP)

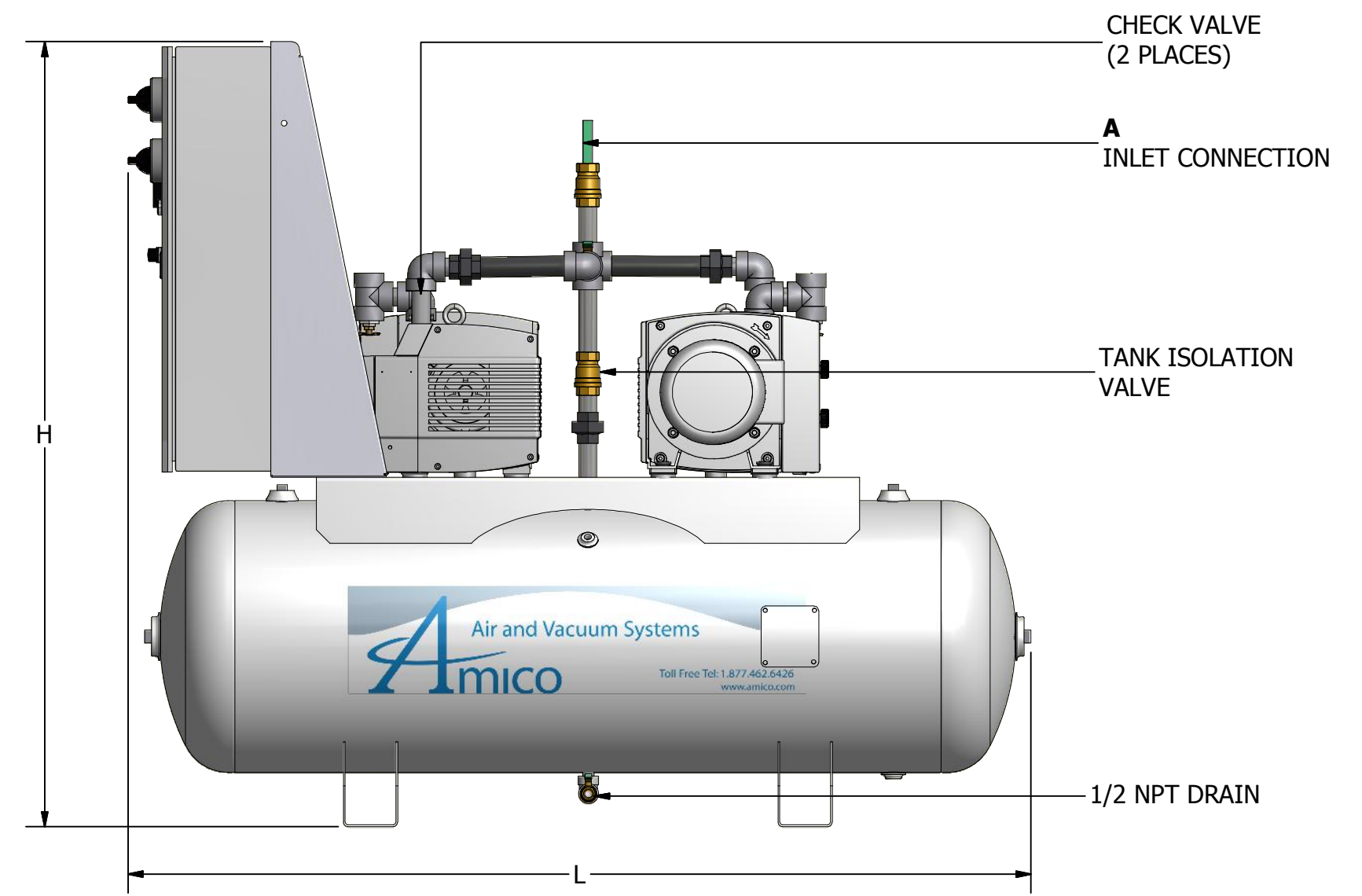
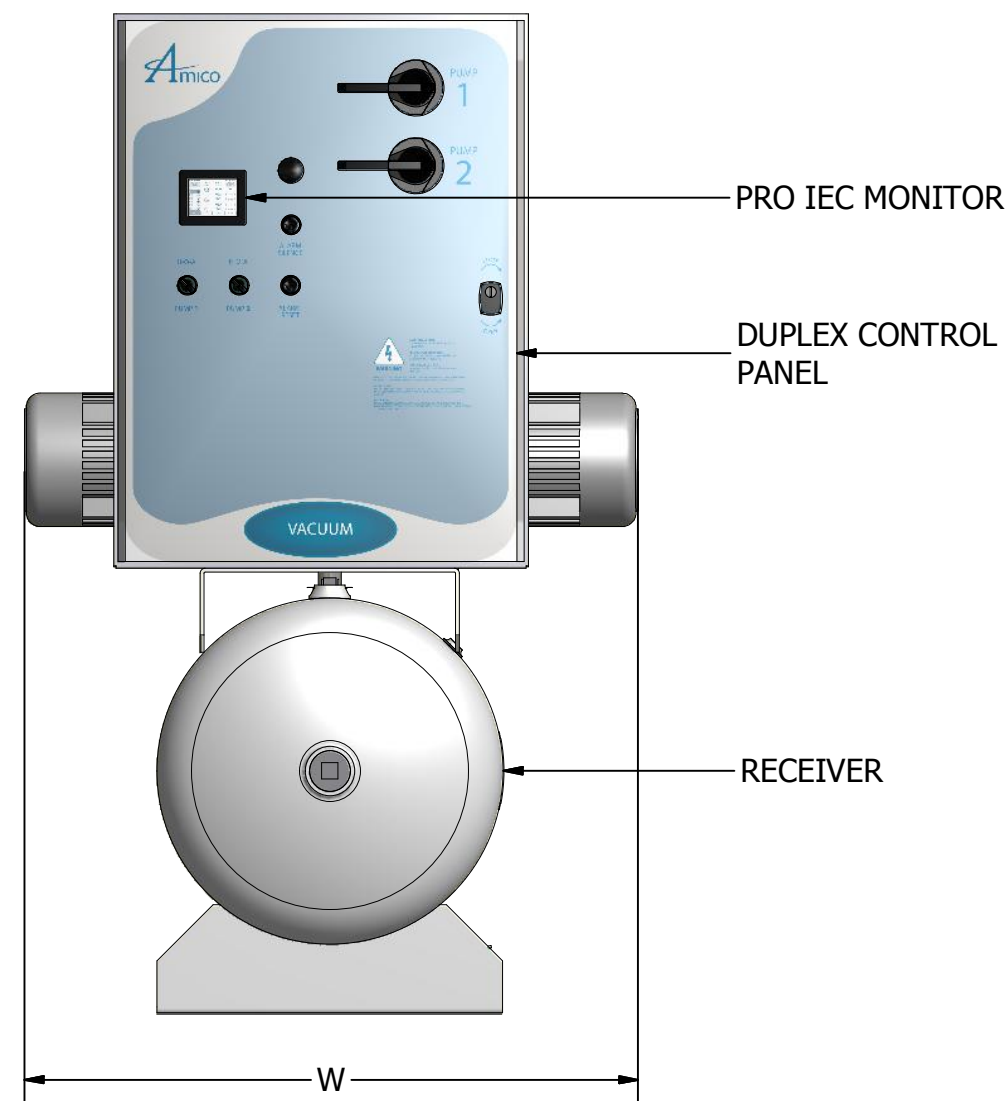
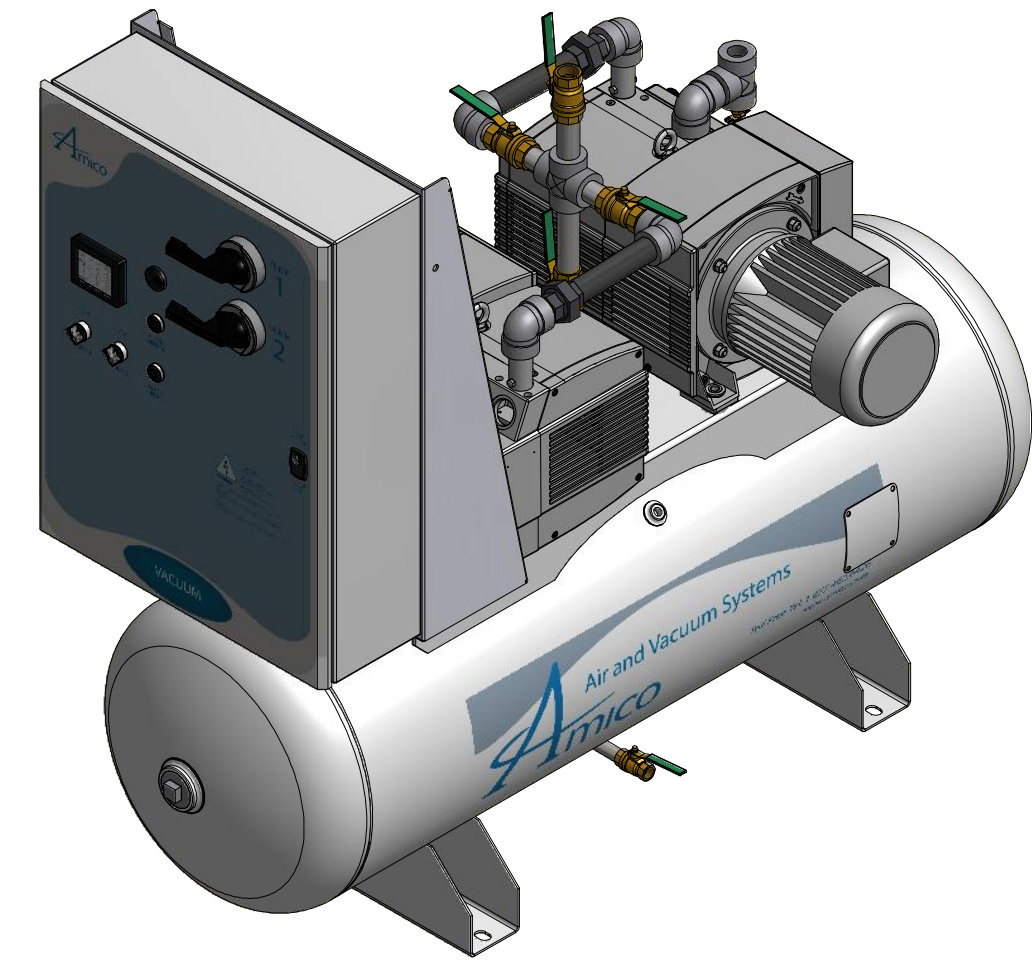
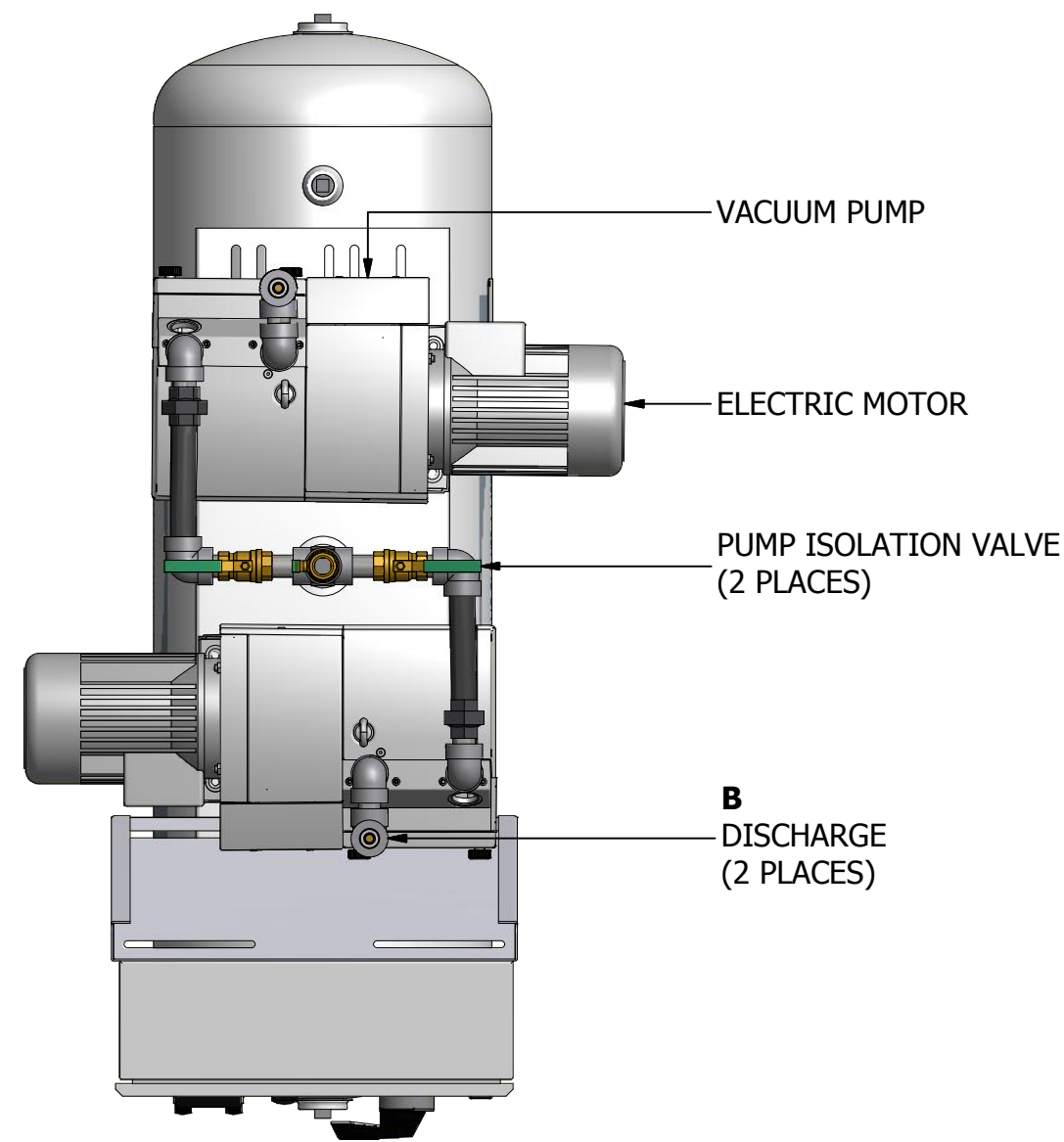

DIMENSIONS SUBJECT TO CHANGE WITHOUT NOTICE

ADDITIONAL MODELS AVAILABLE UPON REQUEST

MODEL	HP (kW)	A INLET NPT	B OUTLET NPT	TANK SIZE GALLON (LITRE)	PUMP SCFM @ 19" HG (LPM)		NFPA SYSTEM CAPACITIES WITH ONE COMPRESSOR ON STANDBY @ 19" HG (LPM)		WEIGHT IN LBS (KG)	SQ. FT. REQUIRED (M <sup>2</sup> )	SYSTEM FLA (WITH ALL COMPRESSORS RUNNING)					SYSTEM BTU/HR	SOUND LEVEL dB (A)	W (M)	L (M)	H (M)
					50 Hz Motor	60 Hz Motor	50 Hz Motor	60 Hz Motor			208V	230V	380V	460V	575V					
V-RVD-D-080P-TH-N-012	1.2 (0.89)	0.75	1.0	80 (303)	4.4 (126)	5.3 (151)	4.4 (126)	5.3 (151)	865 (393)	16.1 (1.49)	8	8	4	4	4	3,056	67	34 (0.86)	68 (1.73)	60 (1.52)
V-RVD-D-080P-TH-N-020	2 (1.49)	0.75	1.0	80 (303)	6.9 (195)	8.3 (234)	6.9 (195)	8.3 (234)	920 (417)	17.0 (1.58)	13	13	8	7	5	5,091	72	36 (0.91)	68 (1.73)	60 (1.52)
V-RVD-D-080P-TH-N-030	3 (2.24)	1.0	1.0	80 (303)	10.4 (295)	12.5 (354)	10.4 (295)	12.5 (354)	1145 (519)	19.4 (1.81)	18	16	13	8	6	7,636	73	40 (1.02)	70 (1.78)	60 (1.52)
V-RVD-D-080P-TH-N-048	4.8 (3.58)	1.5	1.5	120 (454)	18.4 (522)	22.1 (626)	18.4 (522)	22.1 (626)	1455 (660)	23.9 (2.22)	29	27	15	13	10	12,213	77	43 (1.09)	80 (2.03)	64 (1.63)
V-RVD-D-120P-TH-N-064	6.4 (4.77)	2.0	2.0	120 (454)	34.2 (967)	41.0 (1161)	34.2 (967)	41.0 (1161)	2154 (977)	28.9 (2.68)	48	45	26	22	17	16,284	78	52 (1.32)	80 (2.03)	64 (1.63)
V-RVD-D-120P-TH-N-089	8.9 (6.64)	2.0	2.0	120 (454)	42.7 (1209)	51.3 (1451)	42.7 (1209)	51.3 (1451)	2050 (972)	28.9 (2.68)	55	51	30	25	19	22,645	79	52 (1.32)	80 (2.03)	64 (1.63)



85 Fulton Way, Richmond Hill  
Ontario, L4B 2N4 Canada  
71 East Industry Court  
Deer Park, NY 11729  
Direct Tel: 905.764.0800  
Tel: 1.877.462.6426  
Fax: 1.866.440.4986

# ROTARY VANE - DRY DUPLEX STACK MOUNTED VACUUM SYSTEM (1.2 HP - 17.7 HP)

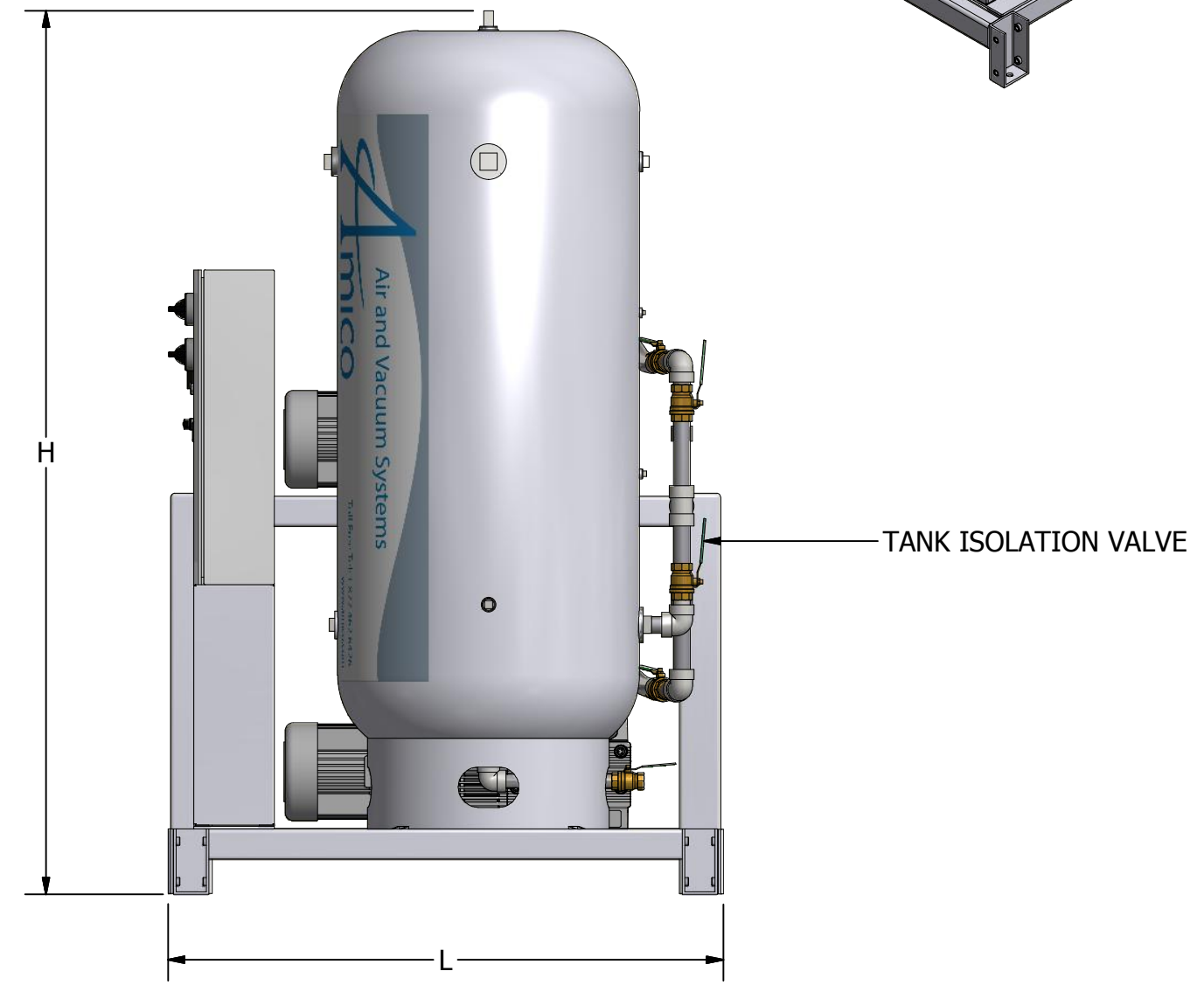
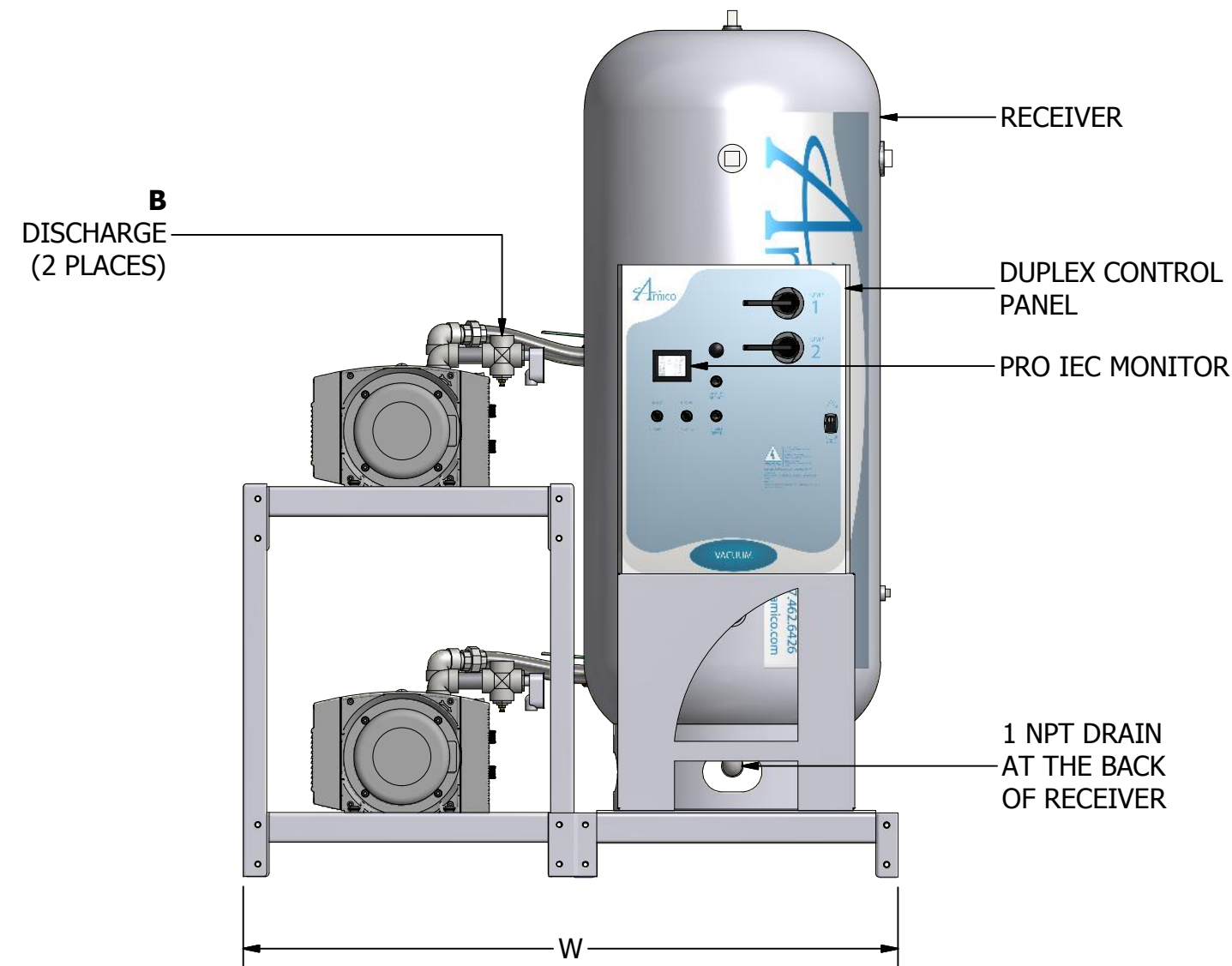
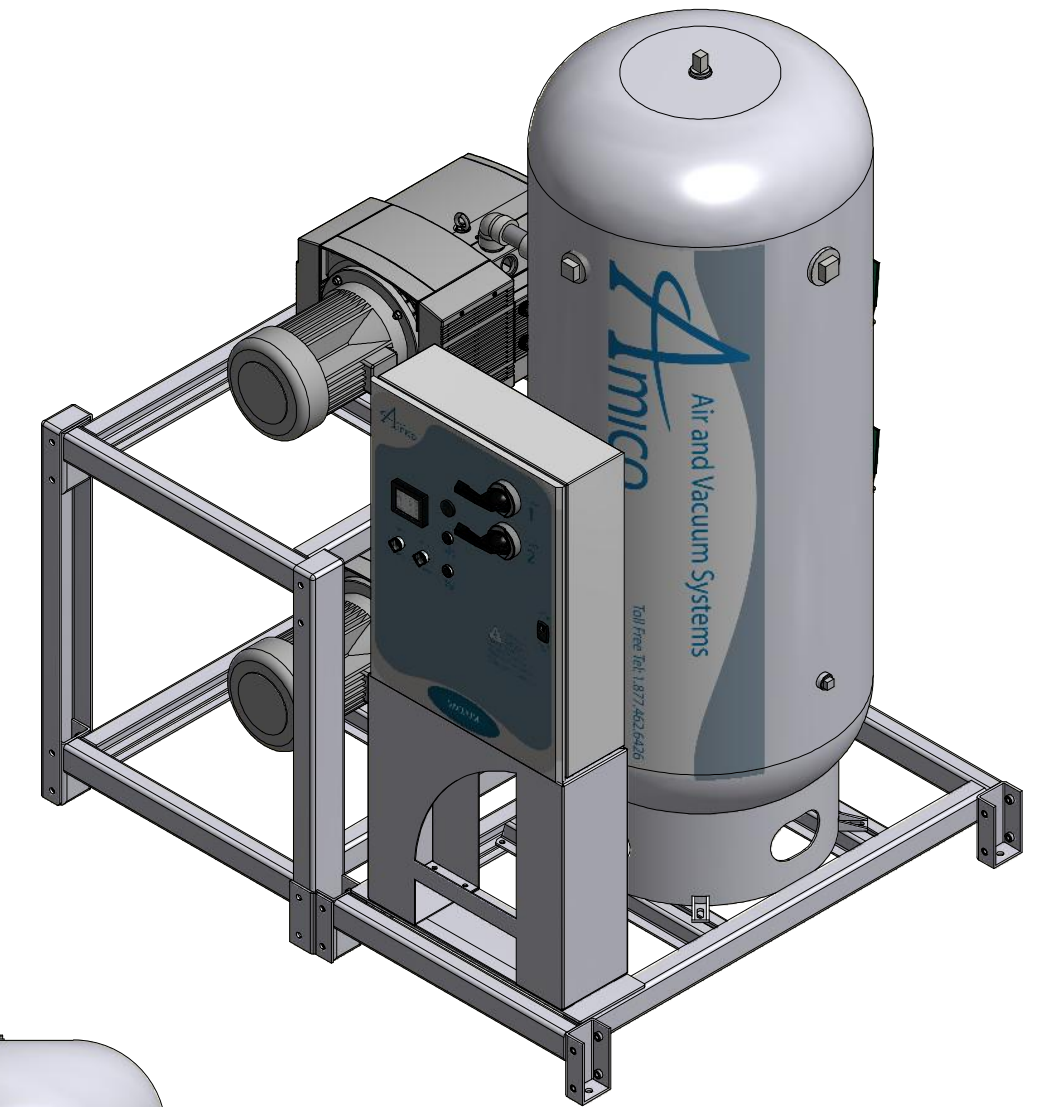
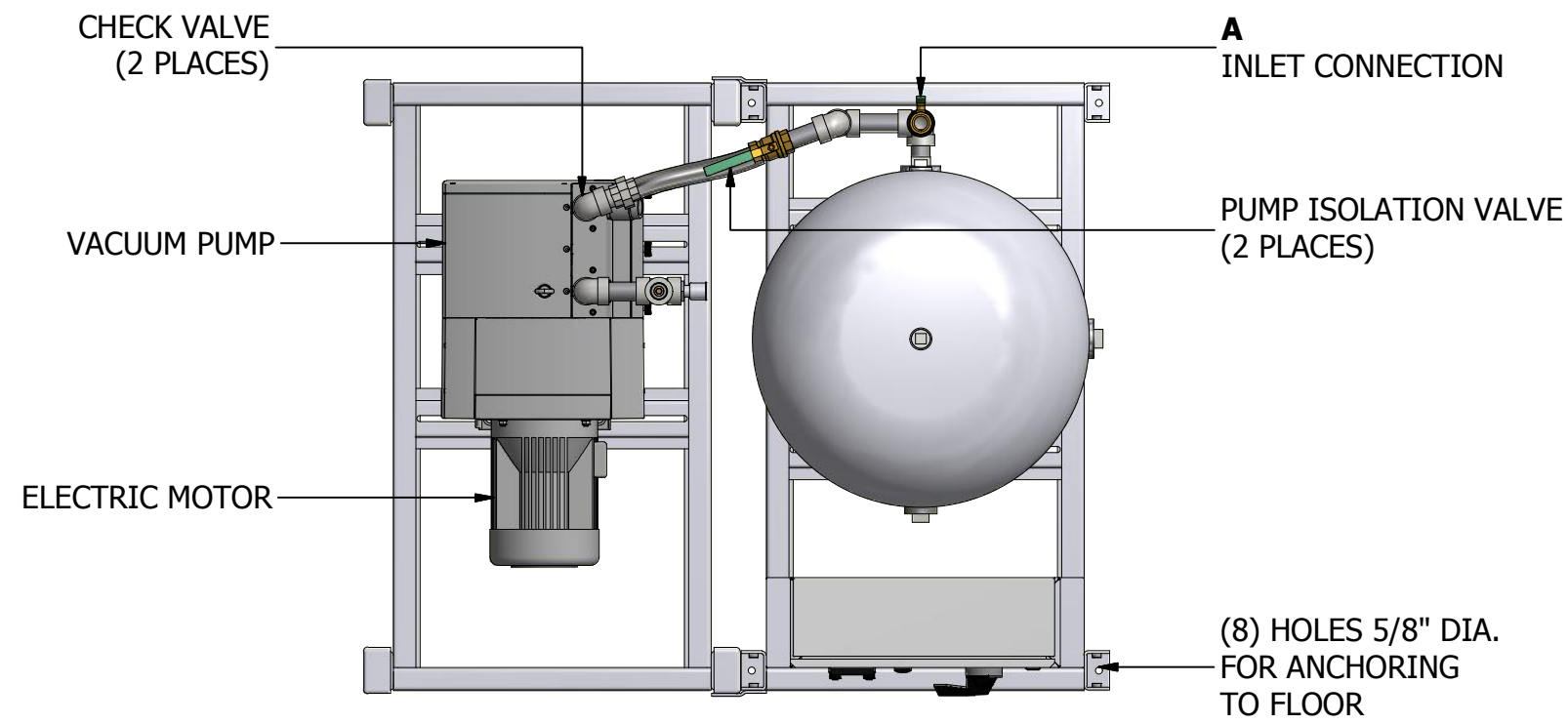

DIMENSIONS SUBJECT TO CHANGE WITHOUT NOTICE

MODEL	HP (kW)	A INLET NPT	B OUTLET NPT	TANK SIZE GALLON (LITRE)	PUMP SCFM @ 19" HG (LPM)		NFPA SYSTEM CAPACITIES WITH ONE COMPRESSOR ON STANDBY @ 19" HG (LPM)		WEIGHT IN LBS (KG)	SQ. FT. REQUIRED (M <sup>2</sup> )	SYSTEM FLA (WITH ALL COMPRESSORS RUNNING)					SYSTEM BTU/HR	SOUND LEVEL dB (A)	W (M)	L (M)	H (M)
					50 Hz Motor	60 Hz Motor	50 Hz Motor	60 Hz Motor			208V	230V	380V	460V	575V					
V-RVD-D-200P-SS-N-012*	1.2 (0.89)	0.75	1.0	200 (757)	4.4 (126)	5.3 (151)	4.4 (126)	5.3 (151)	1375 (624)	25.7 (2.38)	8	8	4	4	4	3,056	67	66 (1.68)	56 (1.42)	91 (2.31)
V-RVD-D-200P-SS-N-020*	2 (1.49)	0.75	1.0	200 (757)	6.9 (195)	8.3 (234)	6.9 (195)	8.3 (234)	1430 (649)	25.7 (2.38)	13	13	8	7	5	5,091	72	66 (1.68)	56 (1.42)	91 (2.31)
V-RVD-D-200P-SS-N-030*	3 (2.24)	1.0	1.0	200 (757)	10.4 (295)	12.5 (354)	10.4 (295)	12.5 (354)	1655 (751)	25.7 (2.38)	18	16	13	8	6	7,636	73	66 (1.68)	56 (1.42)	91 (2.31)
V-RVD-D-200P-SS-N-048	4.8 (3.58)	1.5	1.5	200 (757)	18.4 (522)	22.1 (626)	18.4 (522)	22.1 (626)	1989 (902)	26.1 (2.42)	29	27	15	13	10	12,213	77	67 (1.70)	56 (1.42)	91 (2.31)
V-RVD-D-200P-SS-N-064	6.4 (4.77)	2.0	2.0	200 (757)	34.2 (968)	41.0 (1161)	34.2 (968)	41.0 (1161)	2738 (1242)	30.2 (2.81)	48	45	26	22	17	16,284	78	67 (1.70)	65 (1.65)	91 (2.31)
V-RVD-D-200P-SS-N-089	8.9 (6.64)	2.0	2.0	200 (757)	42.7 (1209)	51.3 (1451)	42.7 (1209)	51.3 (1451)	2617 (1187)	30.2 (2.81)	55	51	30	25	19	22,645	79	67 (1.70)	65 (1.65)	91 (2.31)
V-RVD-D-200P-SS-N-121	12.1 (9.02)	4.0	4.0	200 (757)	64.8 (1836)	77.8 (2203)	64.8 (1836)	77.8 (2203)	3311 (1502)	30.2 (2.81)	76	71	42	36	31	30,788	79	67 (1.70)	65 (1.65)	91 (2.31)
V-RVD-D-200P-SS-N-177*	17.7 (13.2)	4.0	4.0	200 (757)	86.2 (2440)	103.4 (2928)	86.2 (2440)	103.4 (2928)	3453 (1566)	51.1 (4.75)	105	96	54	48	46	45,036	80	92 (2.34)	83 (2.11)	90 (2.29)

\*SYSTEM CONFIGURATION DIFFERS FROM MODEL SHOWN  
ADDITIONAL MODELS AVAILABLE UPON REQUEST



85 Fulton Way, Richmond Hill  
Ontario, L4B 2N4 Canada  
71 East Industry Court  
Deer Park, NY 11729  
Direct Tel: 905.764.0800  
Tel: 1.877.462.6426  
Fax: 1.866.440.4986

# ROTARY VANE - DRY DUPLEX "SPACE SAVER" VACUUM SYSTEM (1.2 HP - 8.9 HP)

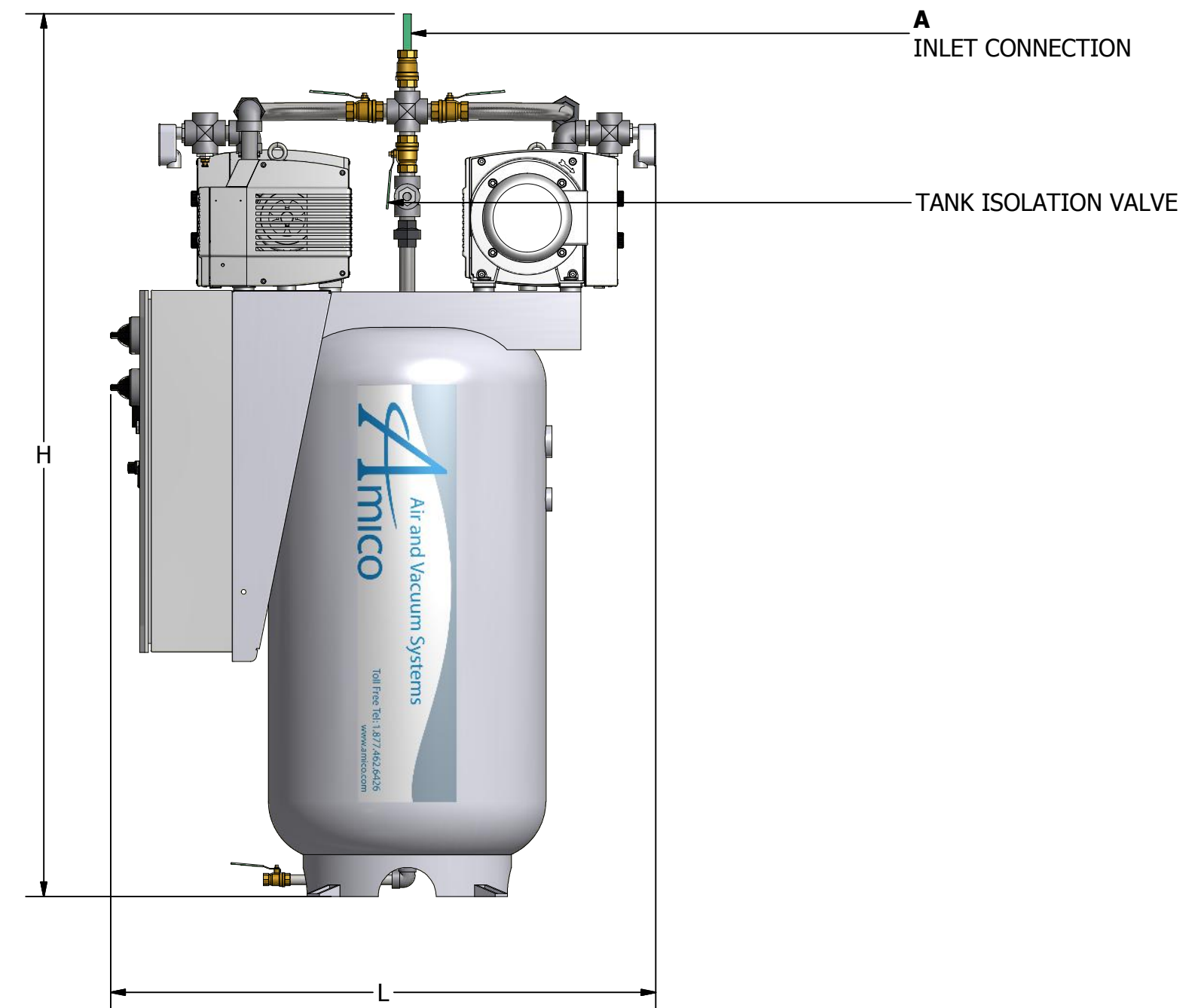
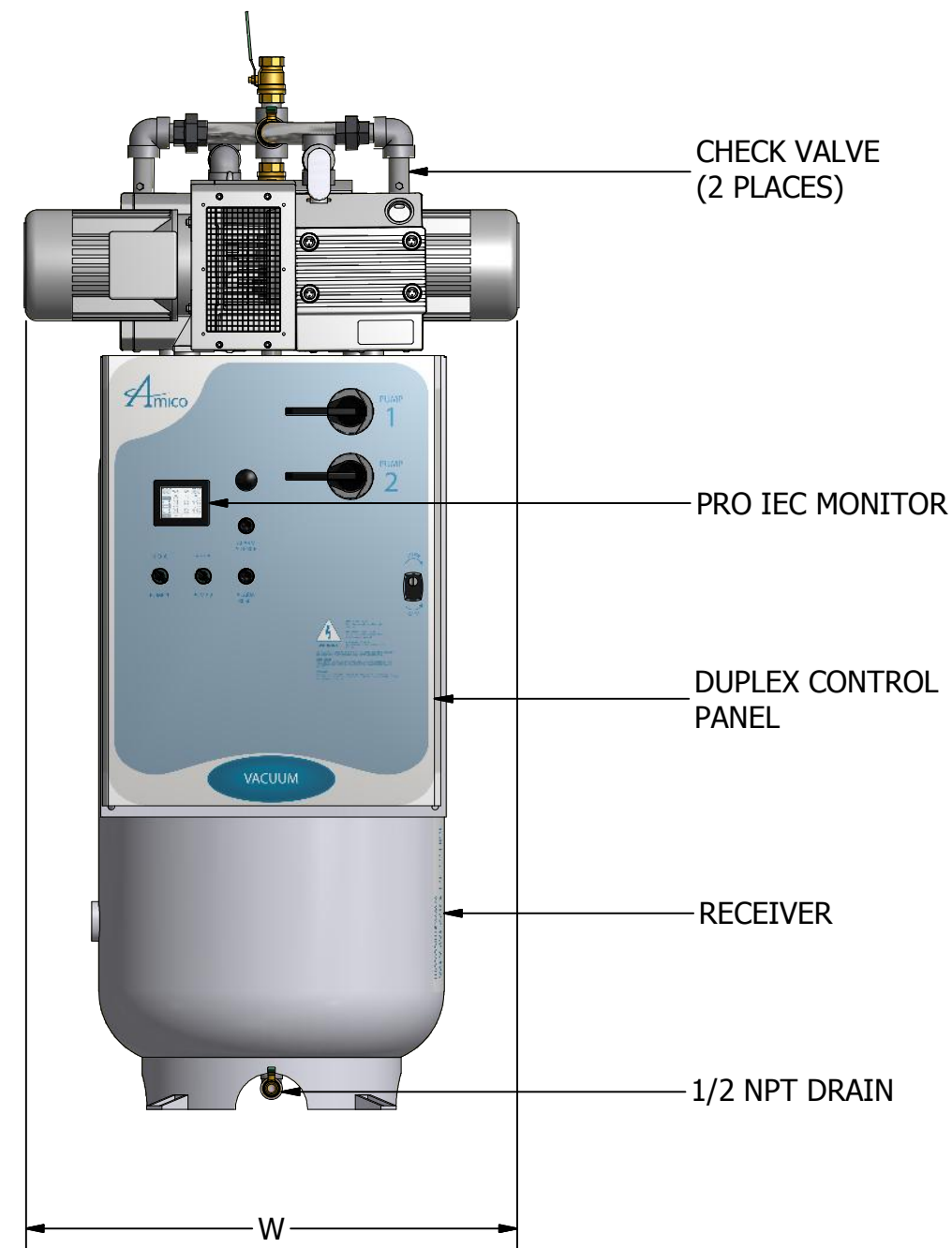
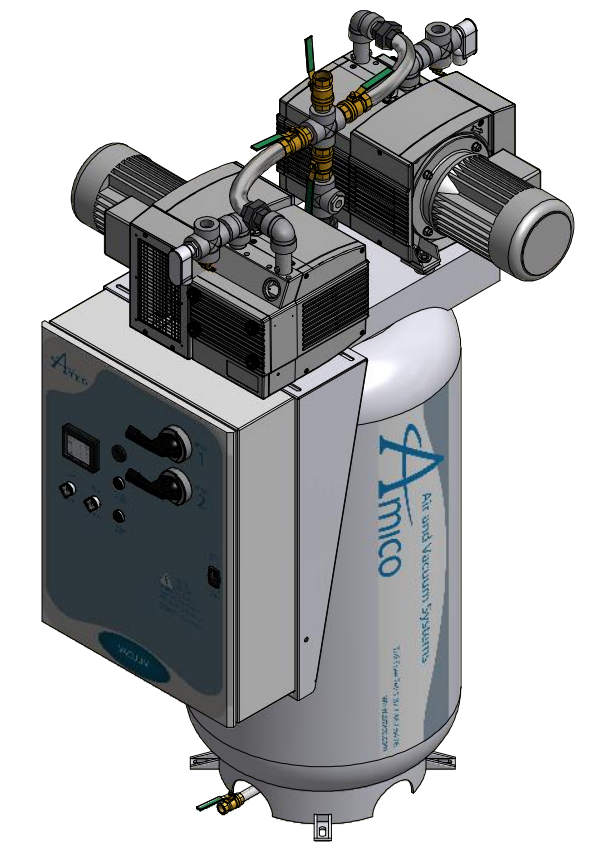
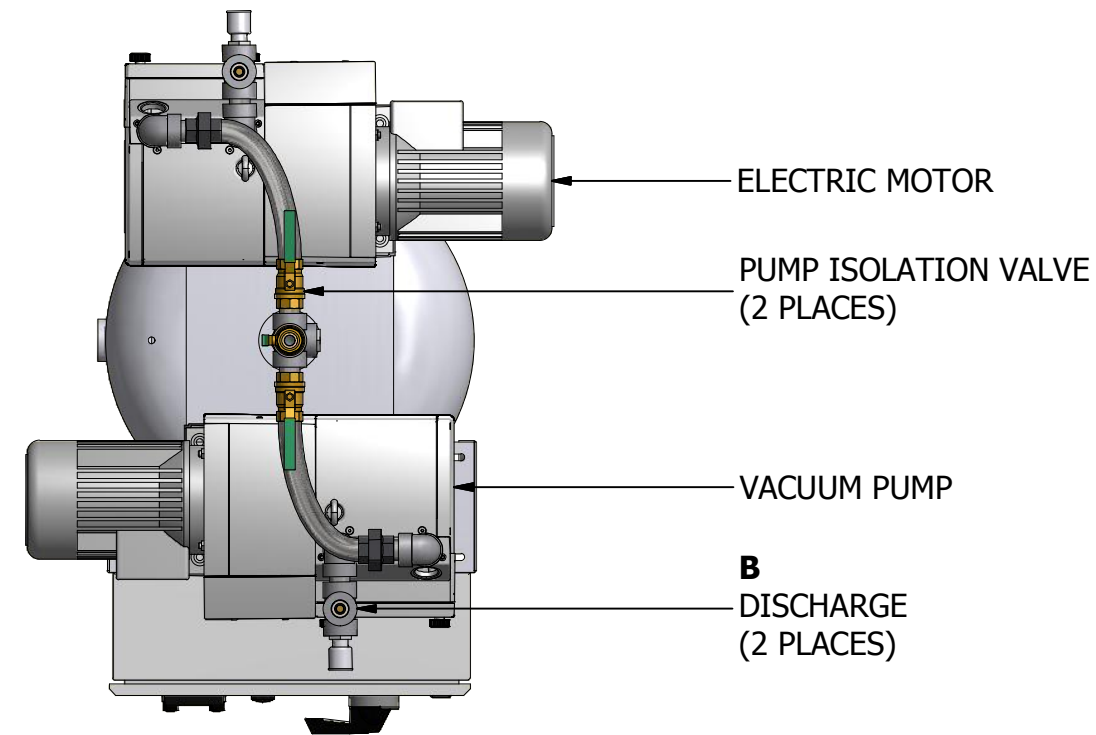

DIMENSIONS SUBJECT TO CHANGE WITHOUT NOTICE

MODEL	HP (kW)	A INLET NPT	B OUTLET NPT	TANK SIZE GALLON (LITRE)	PUMP SCFM @ 19" HG (LPM)		NFPA SYSTEM CAPACITIES WITH ONE COMPRESSOR ON STANDBY @ 19" HG (LPM)		WEIGHT IN LBS (KG)	SQ. FT. REQUIRED (M <sup>2</sup> )	SYSTEM FLA (WITH ALL COMPRESSORS RUNNING)					SYSTEM BTU/HR	SOUND LEVEL dB (A)	W (M)	L (M)	H (M)
					50 Hz Motor	60 Hz Motor	50 Hz Motor	60 Hz Motor			208V	230V	380V	460V	575V					
					V-RVD-D-080P-TS-N-012	1.2 (0.89)	0.75	1.0			80 (303)	4.4 (126)	5.3 (151)	4.4 (126)	5.3 (151)					
V-RVD-D-080P-TS-N-020	2 (1.49)	0.75	1.0	80 (303)	6.9 (195)	8.3 (234)	6.9 (195)	8.3 (234)	914 (415)	10.9 (1.02)	13	13	8	7	5	5,091	72	35 (0.89)	45 (1.14)	77 (1.96)
V-RVD-D-080P-TS-N-030	3 (2.24)	1.0	1.0	80 (303)	10.4 (295)	12.5 (354)	10.4 (295)	12.5 (354)	1089 (494)	12.8 (1.19)	18	16	13	8	6	7,636	73	37 (0.94)	50 (1.27)	80 (2.03)
V-RVD-D-080P-TS-N-048	4.8 (3.58)	1.5	1.5	120 (454)	18.4 (522)	22.1 (626)	18.4 (522)	22.1 (626)	1438 (652)	17.3 (1.61)	29	27	15	13	10	12,213	77	47 (1.19)	53 (1.35)	86 (2.18)
V-RVD-D-120P-TS-N-064	6.4 (4.77)	1.5	1.5	120 (454)	25.4 (718)	30.4 (862)	25.4 (718)	30.4 (862)	1537 (697)	17.3 (1.61)	36	34	19	17	15	16,284	79	47 (1.19)	53 (1.35)	86 (2.18)
V-RVD-D-120P-TS-N-089	8.9 (6.64)	2.0	2.0	120 (454)	42.7 (1209)	51.3 (1451)	42.7 (1209)	51.3 (1451)	2033 (922)	27.5 (2.55)	55	51	30	25	19	22,645	79	60 (1.52)	66 (1.68)	86 (2.18)

ADDITIONAL MODELS AVAILABLE UPON REQUEST



85 Fulton Way, Richmond Hill  
Ontario, L4B 2N4 Canada  
71 East Industry Court  
Deer Park, NY 11729  
Direct Tel: 905.764.0800  
Tel: 1.877.462.6426  
Fax: 1.866.440.4986

# ROTARY VANE - DRY QUADRAPLEX STACK MOUNTED VACUUM SYSTEM (1.2 HP - 17.7 HP)

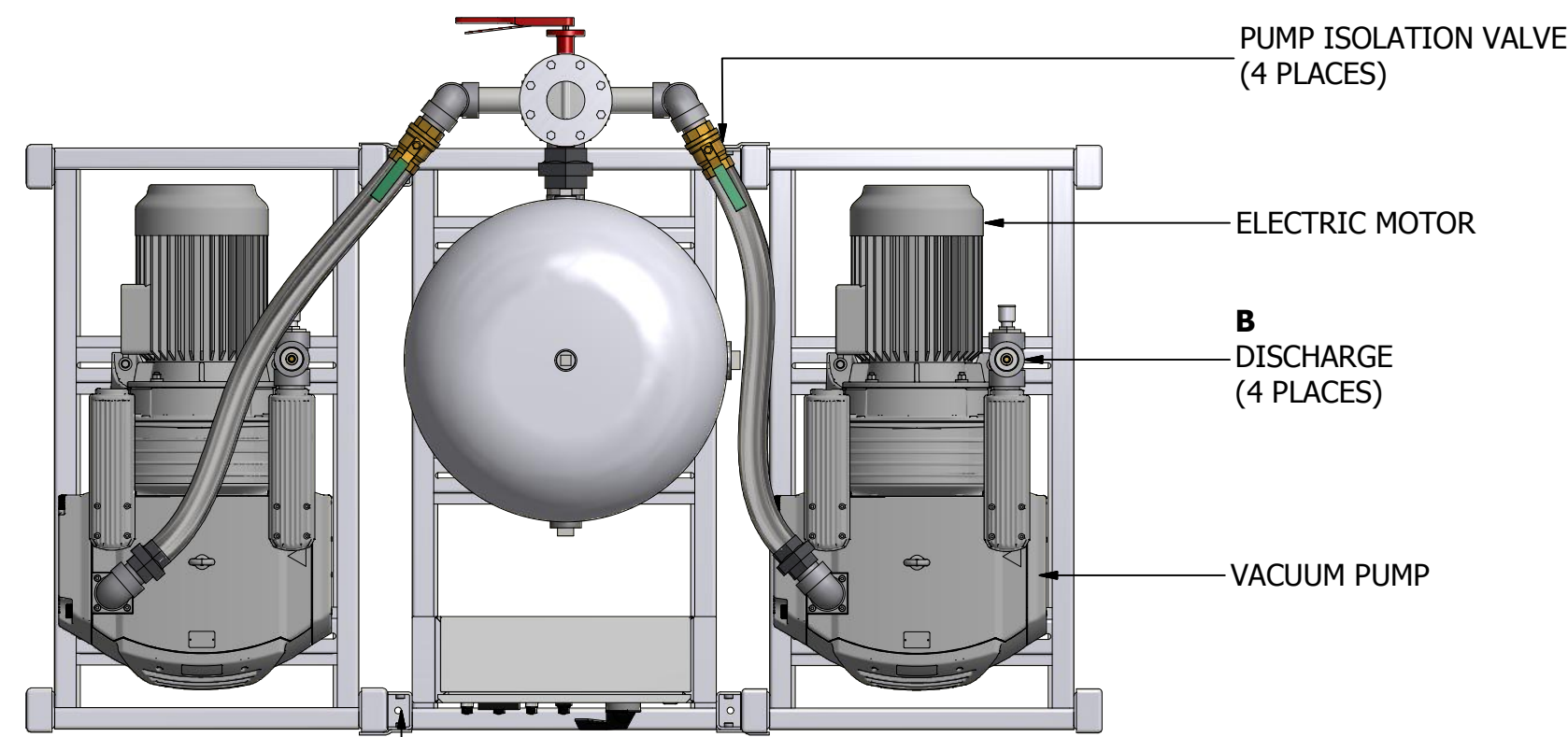

(12) HOLES 5/8" DIA.  
FOR ANCHORING  
TO FLOOR

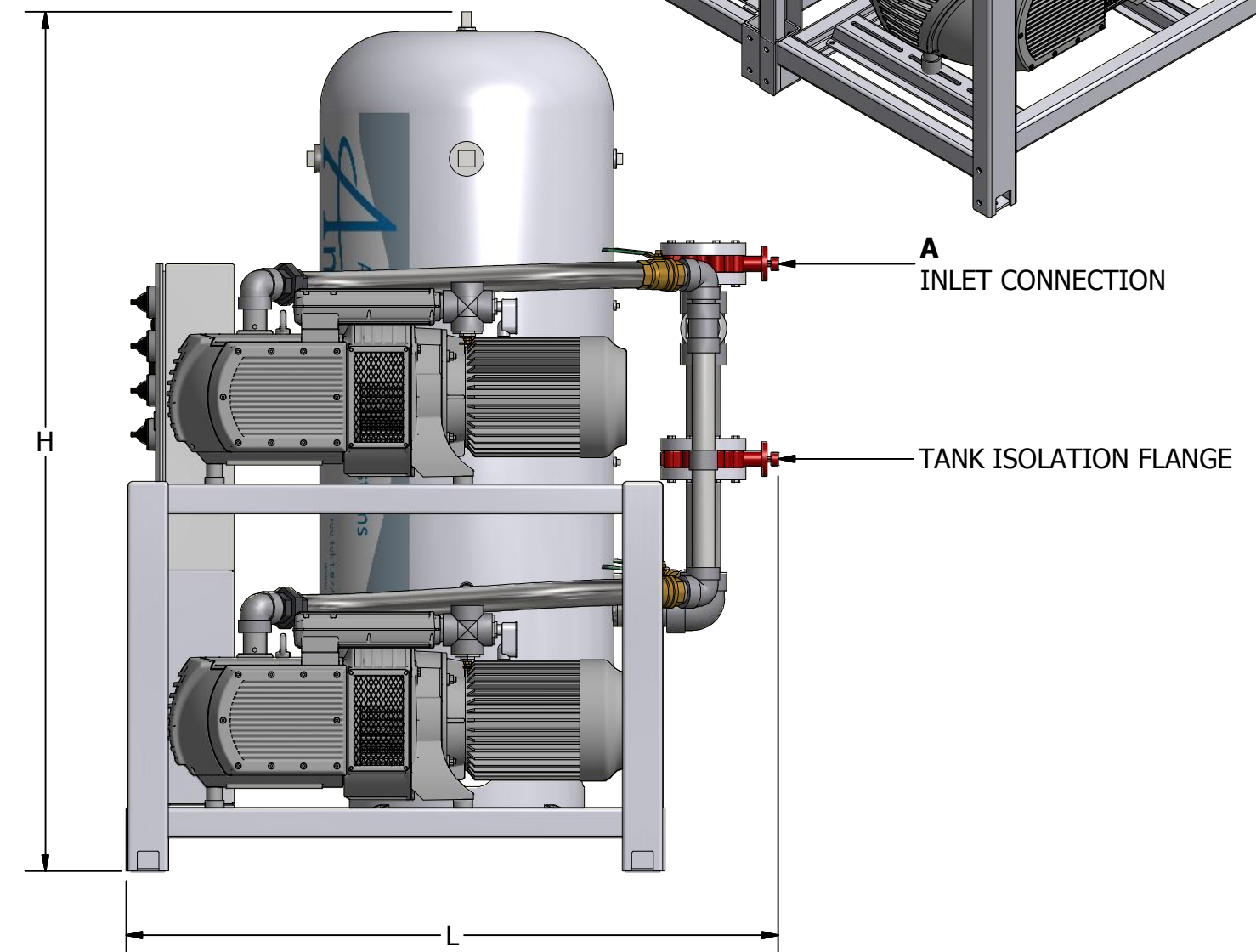
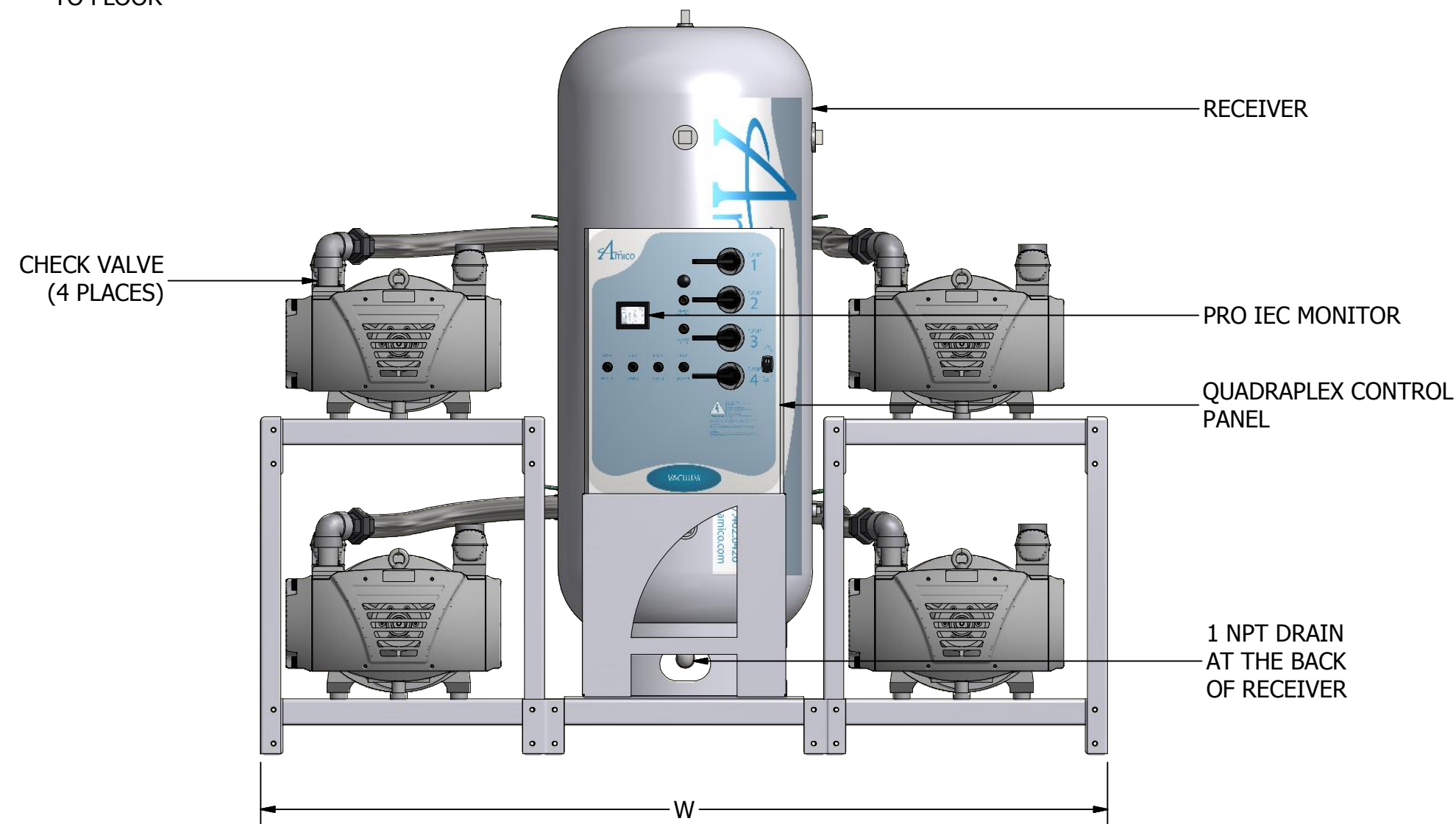
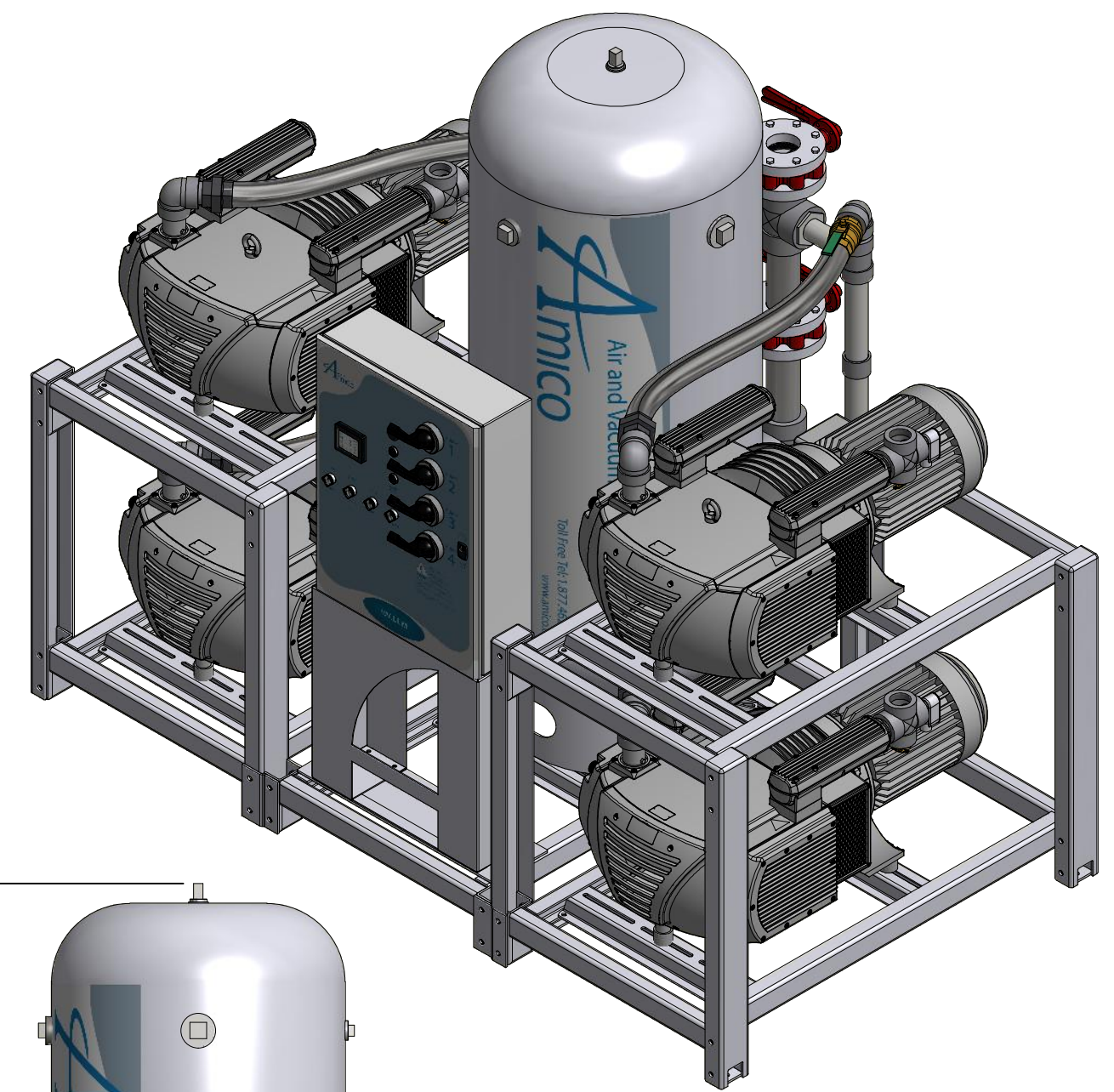

DIMENSIONS SUBJECT TO CHANGE WITHOUT NOTICE

MODEL	HP (kW)	A INLET NPT	B OUTLET NPT	TANK SIZE GALLON (LITRE)	PUMP SCFM @ 19" HG (LPM)		NFPA SYSTEM CAPACITIES WITH ONE COMPRESSOR ON STANDBY @ 19" HG (LPM)		WEIGHT IN LBS (KG)	SQ. FT. REQUIRED (M <sup>2</sup> )	SYSTEM FLA (WITH ALL COMPRESSORS RUNNING)					SYSTEM BTU/HR	SOUND LEVEL dB (A)	W (M)	L (M)	H (M)
					50 Hz Motor	60 Hz Motor	50 Hz Motor	60 Hz Motor			208V	230V	380V	460V	575V					
V-RVD-Q-200P-SS-N-012*	1.2 (0.89)	1.25	1.0	200 (757)	4.4 (126)	5.3 (151)	13.3 (377)	16.0 (452)	1836 (833)	26.1 (2.42)	16	15	9	9	8	9,168	72	67 (1.70)	56 (1.42)	91 (2.31)
V-RVD-Q-200P-SS-N-020*	2 (1.49)	1.25	1.0	200 (757)	6.9 (195)	8.3 (234)	20.7 (585)	24.8 (703)	1946 (883)	26.1 (2.42)	27	26	15	14	9	15,273	77	67 (1.70)	56 (1.42)	91 (2.31)
V-RVD-Q-200P-SS-N-030*	3 (2.24)	1.5	1.0	200 (757)	10.4 (295)	12.5 (354)	31.3 (885)	37.5 (1062)	2345 (1064)	26.1 (2.42)	35	32	26	16	12	22,908	78	67 (1.70)	56 (1.42)	91 (2.31)
V-RVD-Q-200P-SS-N-048	4.8 (3.58)	3.0	1.5	200 (757)	18.4 (522)	22.1 (626)	55.3 (1565)	66.3 (1877)	2871 (1302)	45.6 (4.24)	57	54	31	27	20	36,639	82	101 (2.57)	65 (1.65)	91 (2.31)
V-RVD-Q-200P-SS-N-064	6.4 (4.77)	4.0	2.0	200 (757)	34.2 (968)	41.0 (1161)	102.5 (2904)	123 (3483)	4269 (1936)	45.6 (4.24)	96	90	52	45	33	48,852	83	101 (2.57)	65 (1.65)	91 (2.31)
V-RVD-Q-200P-SS-N-089	8.9 (6.64)	4.0	2.0	200 (757)	42.7 (1209)	51.3 (1451)	128.3 (3632)	153.9 (4358)	4027 (1827)	45.6 (4.24)	109	102	59	51	39	67,935	84	101 (2.57)	65 (1.65)	91 (2.31)
V-RVD-Q-200P-SS-N-121	12.1 (9.02)	6.0	4.0	200 (757)	64.8 (1836)	77.8 (2203)	194.5 (5508)	233.4 (6609)	5365 (2433)	49.1 (4.57)	152	142	83	71	63	92,364	84	101 (2.57)	70 (1.78)	91 (2.31)
V-RVD-Q-200P-SS-N-177*	17.7 (13.2)	6.0	4.0	200 (757)	86.2 (2440)	103.4 (2928)	258.5 (7320)	310.2 (8784)	5615 (2547)	80.0 (7.43)	209	192	108	96	92	135,108	85	144 (3.66)	80 (2.03)	90 (2.29)

\*SYSTEM CONFIGURATION DIFFERS FROM MODEL SHOWN

ADDITIONAL MODELS AVAILABLE UPON REQUEST



85 Fulton Way, Richmond Hill  
Ontario, L4B 2N4 Canada  
71 East Industry Court  
Deer Park, NY 11729  
Direct Tel: 905.764.0800  
Tel: 1.877.462.6426  
Fax: 1.866.440.4986

# ROTARY VANE - DRY TRIPLEX STACK MOUNTED VACUUM SYSTEM (1.2 HP - 17.7 HP)

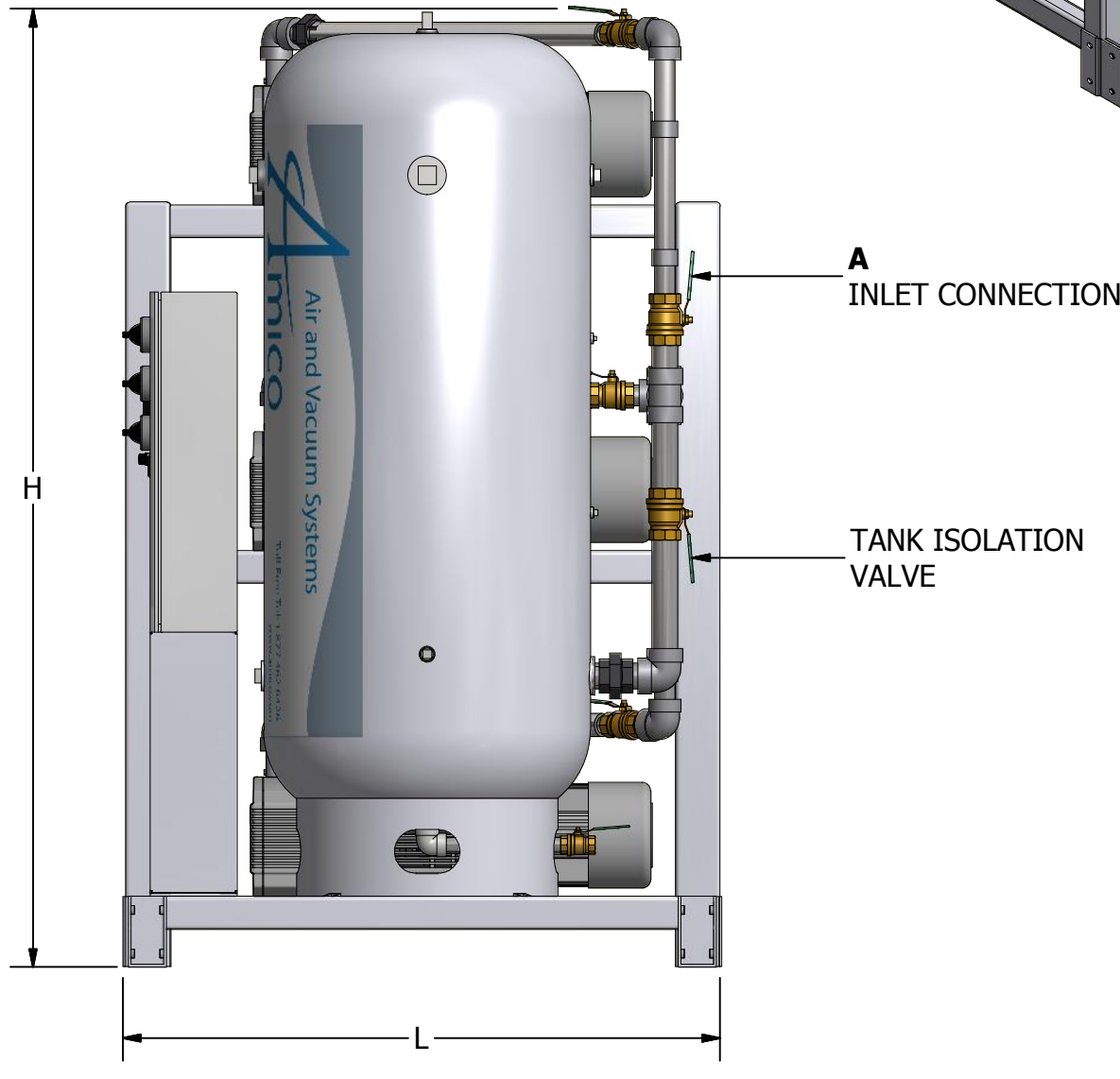
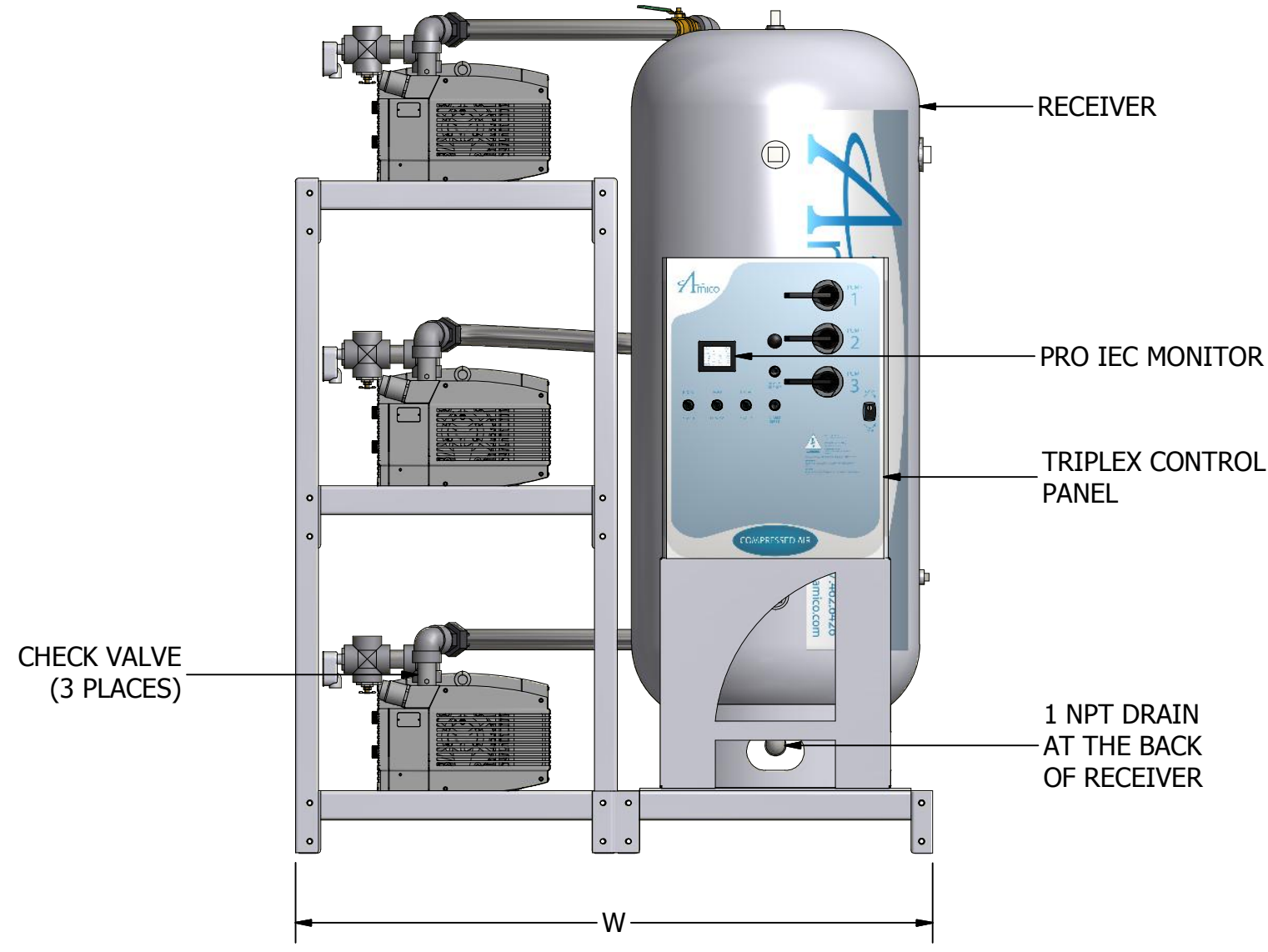
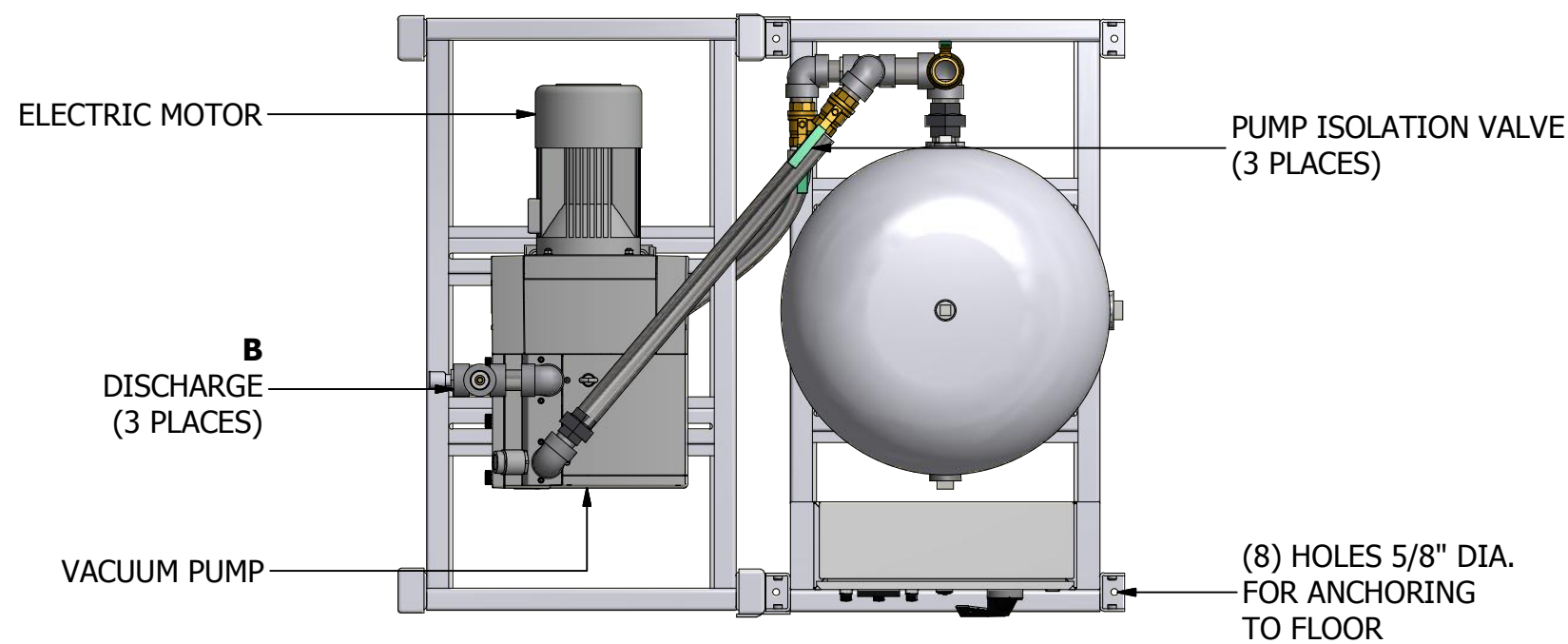

DIMENSIONS SUBJECT TO CHANGE WITHOUT NOTICE

MODEL	HP (kW)	A INLET NPT	B OUTLET NPT	TANK SIZE GALLON (LITRE)	PUMP SCFM @ 19" HG (LPM)		NFPA SYSTEM CAPACITIES WITH ONE COMPRESSOR ON STANDBY @ 19" HG (LPM)		WEIGHT IN LBS (KG)	SQ. FT. REQUIRED (M <sup>2</sup> )	SYSTEM FLA (WITH ALL COMPRESSORS RUNNING)					SYSTEM BTU/HR	SOUND LEVEL dB (A)	W (M)	L (M)	H (M)
					50 Hz Motor	60 Hz Motor	50 Hz Motor	60 Hz Motor			208V	230V	380V	460V	575V					
V-RVD-T-200P-SS-N-012*	1.2 (0.89)	1.0	1.0	200 (757)	4.4 (126)	5.3 (151)	8.9 (251)	10.6 (301)	1682 (763)	26.1 (2.42)	12	12	7	6	6	6,112	70	67 (1.70)	56 (1.42)	91 (2.31)
V-RVD-T-200P-SS-N-020*	2 (1.49)	1.0	1.0	200 (757)	6.9 (195)	8.3 (234)	13.8 (390)	16.5 (468)	1764 (800)	26.1 (2.42)	20	19	11	11	7	10,182	75	67 (1.70)	56 (1.42)	91 (2.31)
V-RVD-T-200P-SS-N-030*	3 (2.24)	1.25	1.0	200 (757)	10.4 (295)	12.5 (354)	20.8 (589)	25.0 (708)	2076 (942)	26.1 (2.42)	26	24	19	12	9	15,272	76	67 (1.70)	56 (1.42)	91 (2.31)
V-RVD-T-200P-SS-N-048	4.8 (3.58)	2.0	1.5	200 (757)	18.4 (522)	22.1 (626)	36.8 (1043)	44.2 (1252)	2442 (1107)	26.1 (2.42)	43	40	23	20	15	24,426	80	67 (1.70)	56 (1.42)	91 (2.31)
V-RVD-T-200P-SS-N-064	6.4 (4.77)	3.0	2.0	200 (757)	34.2 (968)	41.0 (1161)	68.4 (1937)	82.0 (2322)	3515 (1594)	30.2 (2.81)	72	67	39	34	25	32,568	81	67 (1.70)	65 (1.65)	91 (2.31)
V-RVD-T-200P-SS-N-089	8.9 (6.64)	3.0	2.0	200 (757)	42.7 (1209)	51.3 (1451)	85.4 (2419)	102.5 (2902)	3334 (1512)	30.2 (2.81)	82	76	44	38	29	45,290	82	67 (1.70)	65 (1.65)	97 (2.46)
V-RVD-T-200P-SS-N-121	12.1 (9.02)	5.0	4.0	200 (757)	64.8 (1836)	77.8 (2203)	129.7 (3672)	155.6 (4406)	4279 (1941)	48.6 (4.52)	114	107	62	53	47	61,576	82	100 (2.54)	70 (1.78)	91 (2.31)
V-RVD-T-200P-SS-N-177*	17.7 (13.2)	5.0	4.0	200 (757)	86.2 (2440)	103.4 (2928)	172.3 (4880)	206.8 (5856)	4461 (2024)	80.0 (7.43)	157	144	81	72	69	90,072	83	144 (3.66)	80 (2.03)	90 (2.29)

\*SYSTEM CONFIGURATION DIFFERS FROM MODEL SHOWN  
ADDITIONAL MODELS AVAILABLE UPON REQUEST



85 Fulton Way, Richmond Hill  
Ontario, L4B 2N4 Canada  
71 East Industry Court  
Deer Park, NY 11729  
Direct Tel: 905.764.0800  
Tel: 1.877.462.6426  
Fax: 1.866.440.4986  
[www.amico.com](http://www.amico.com)