

CONTACTLESS CLAW - DRY DUPLEX TANK MOUNTED VACUUM SYSTEM (2.0 HP - 10.0 HP)

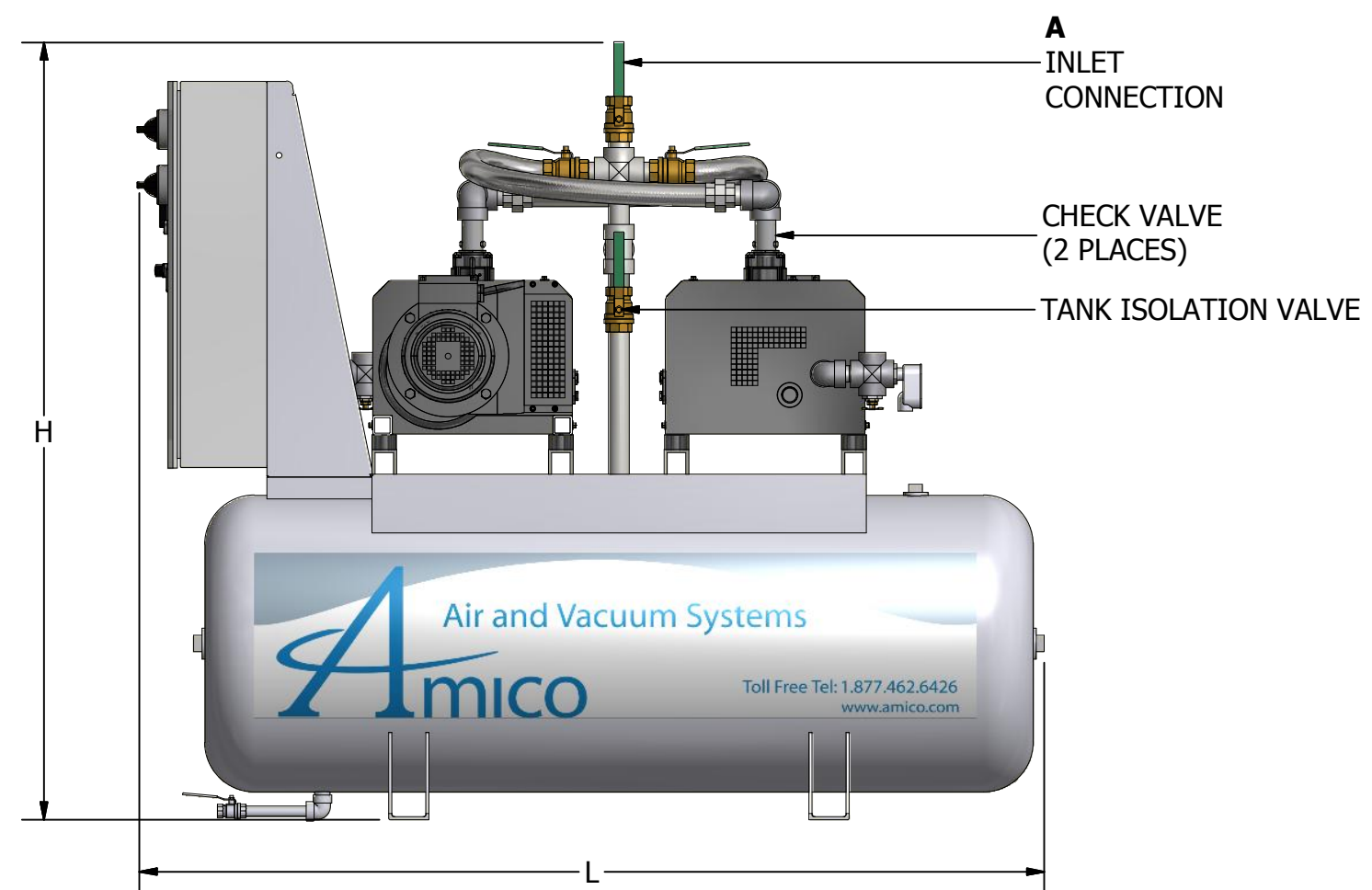
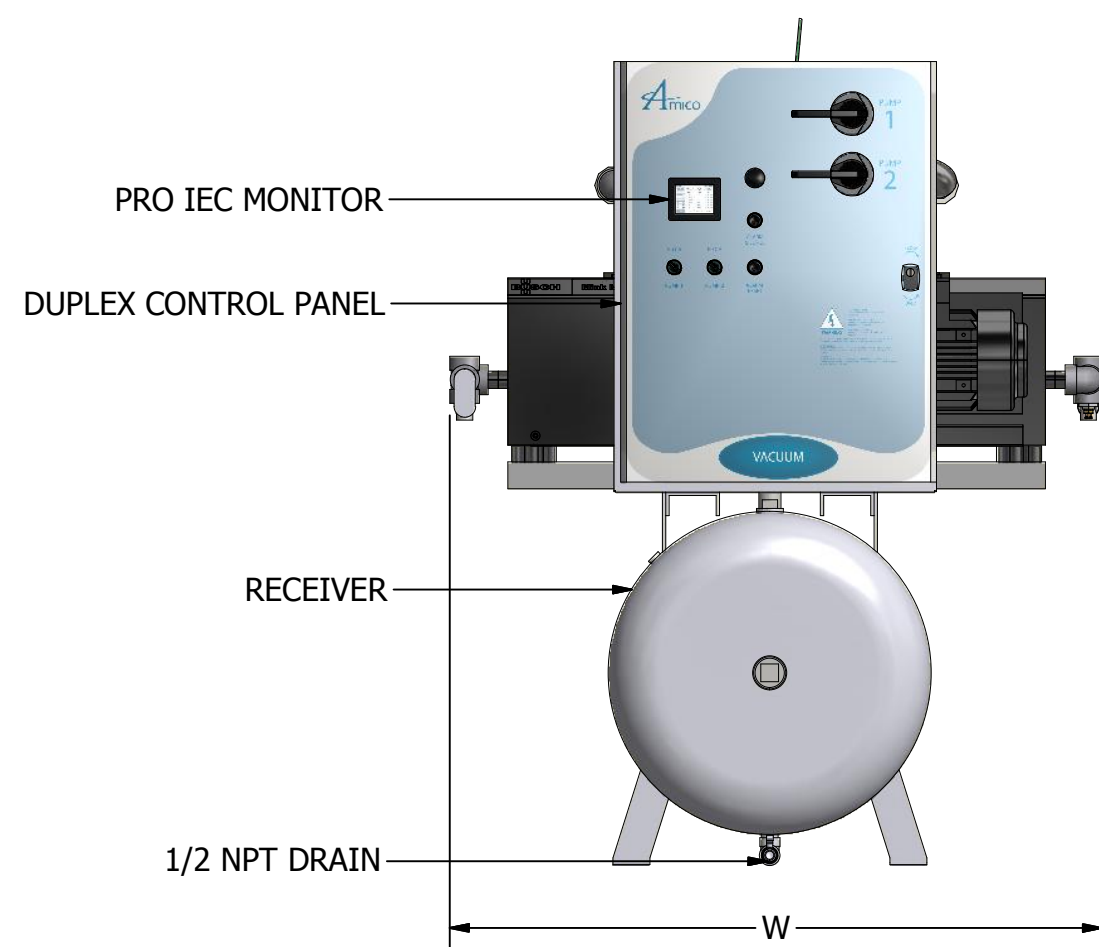
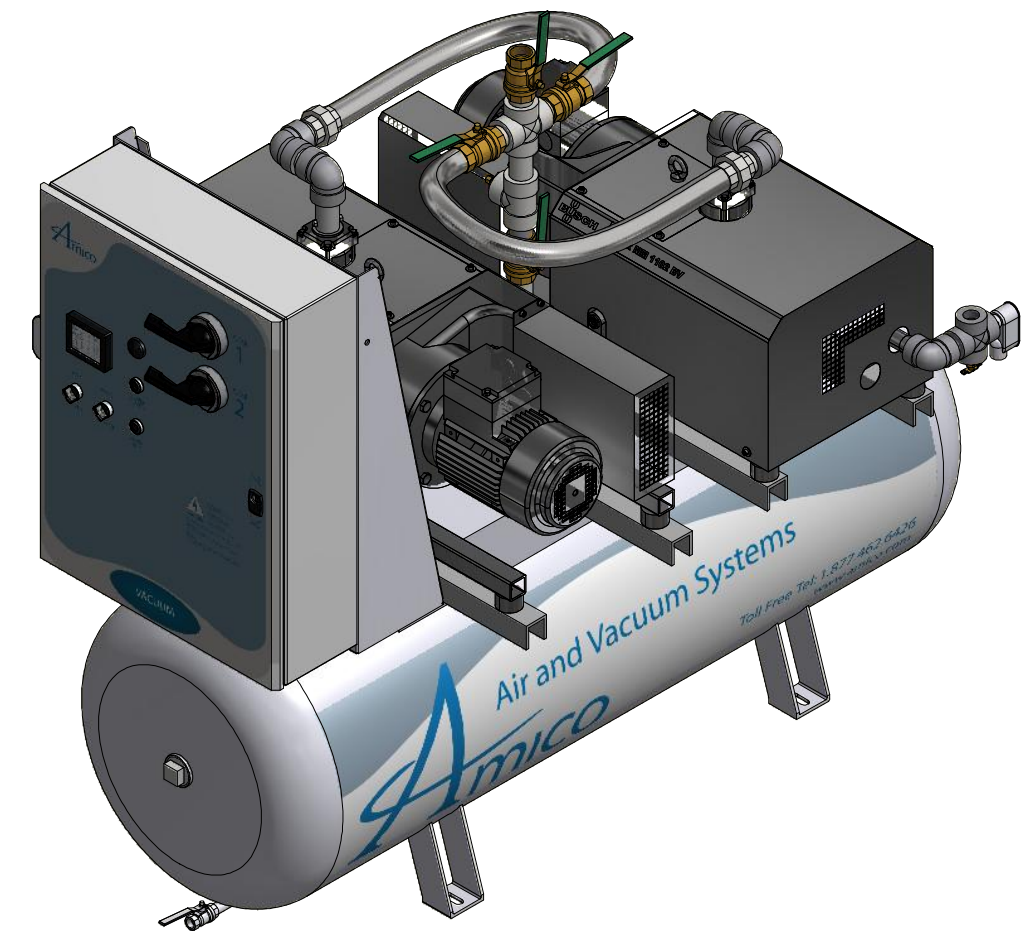
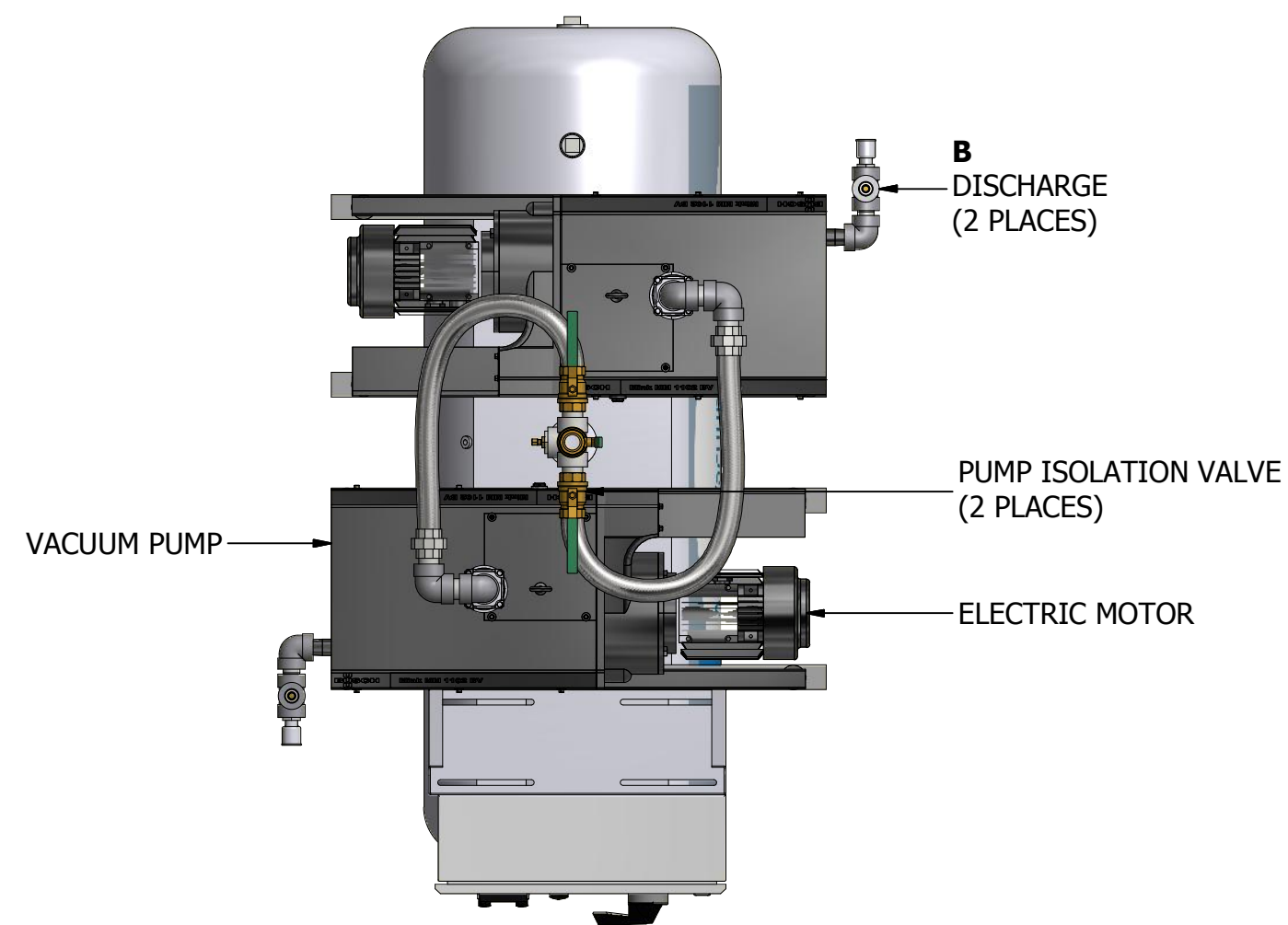

DIMENSIONS SUBJECT TO CHANGE WITHOUT NOTICE

ADDITIONAL MODELS AVAILABLE UPON REQUEST

MODEL	HP (KW)	A INLET NPT	B OUTLET NPT	TANK SIZE GALLON (LITRE)	PUMP SCFM @ 19" HG (LPM)		NFPA SYSTEM CAPACITIES WITH ONE COMPRESSOR ON STANDBY @ 19" HG (LPM)		WEIGHT IN LBS (KG)	SQ. FT. REQUIRED (M ²)	SYSTEM FLA (WITH ALL COMPRESSORS RUNNING)				SYSTEM BTU/HR	SOUND LEVEL dB (A)	W (M)	L (M)	H (M)
					50 Hz Motor	60 Hz Motor	50 Hz Motor	60 Hz Motor			208V	230V	380V	460V					
					V-CCD-D-080P-TH-N-020	2 (1.49)	1.25	1.0			80 (303)	13.3 (378)	16.0 (453)	13.3 (378)					
V-CCD-D-080P-TH-N-030	3 (2.24)	1.25	1.0	80 (303)	17.5 (496)	21.0 (595)	17.5 (496)	21.0 (595)	1657 (751)	28.6 (2.66)	20	19	10	9	7,636	70	55 (1.40)	75 (1.91)	65 (1.65)
V-CCD-D-080P-TH-N-040	4 (2.98)	1.25	1.0	80 (303)	24.2 (684)	29.0 (821)	24.2 (684)	29.0 (821)	1635 (741)	28.6 (2.66)	25	23	12	11	10,178	79	55 (1.40)	75 (1.91)	65 (1.65)
V-CCD-D-080P-TH-N-054	5.4 (4.03)	1.25	1.0	80 (303)	31.7 (897)	38.0 (1076)	31.7 (897)	38.0 (1076)	1657 (751)	28.6 (2.66)	34	30	17	15	13,740	79	55 (1.40)	75 (1.91)	65 (1.65)
V-CCD-D-120P-TH-N-064	6.4 (4.77)	2.0	1.0	120 (454)	43.3 (1227)	52.0 (1472)	43.3 (1227)	52.0 (1472)	2024 (918)	36.7 (3.41)	37	35	19	17	16,284	79	60 (1.52)	88 (2.24)	70 (1.78)
V-CCD-D-120P-TH-N-075	7.5 (5.59)	2.0	1.0	120 (454)	54.2 (1534)	65.0 (1841)	54.2 (1534)	65.0 (1841)	2046 (928)	36.7 (3.41)	48	45	24	23	19,091	79	60 (1.52)	88 (2.24)	70 (1.78)
V-CCD-D-120P-TH-N-100	10 (7.46)	2.0	1.25	120 (454)	60.8 (1722)	73.0 (2067)	60.8 (1722)	73.0 (2067)	2250 (1020)	36.7 (3.41)	54	50	28	25	25,455	82	60 (1.52)	88 (2.24)	70 (1.78)



85 Fulton Way, Richmond Hill
Ontario, L4B 2N4 Canada
71 East Industry Court
Deer Park, NY 11729
Direct Tel: 905.764.0800
Tel: 1.877.462.6426
Fax: 1.866.440.4986

CONTACTLESS CLAW - DRY DUPLEX STACK MOUNTED VACUUM SYSTEM (2.0 HP - 30.0 HP)

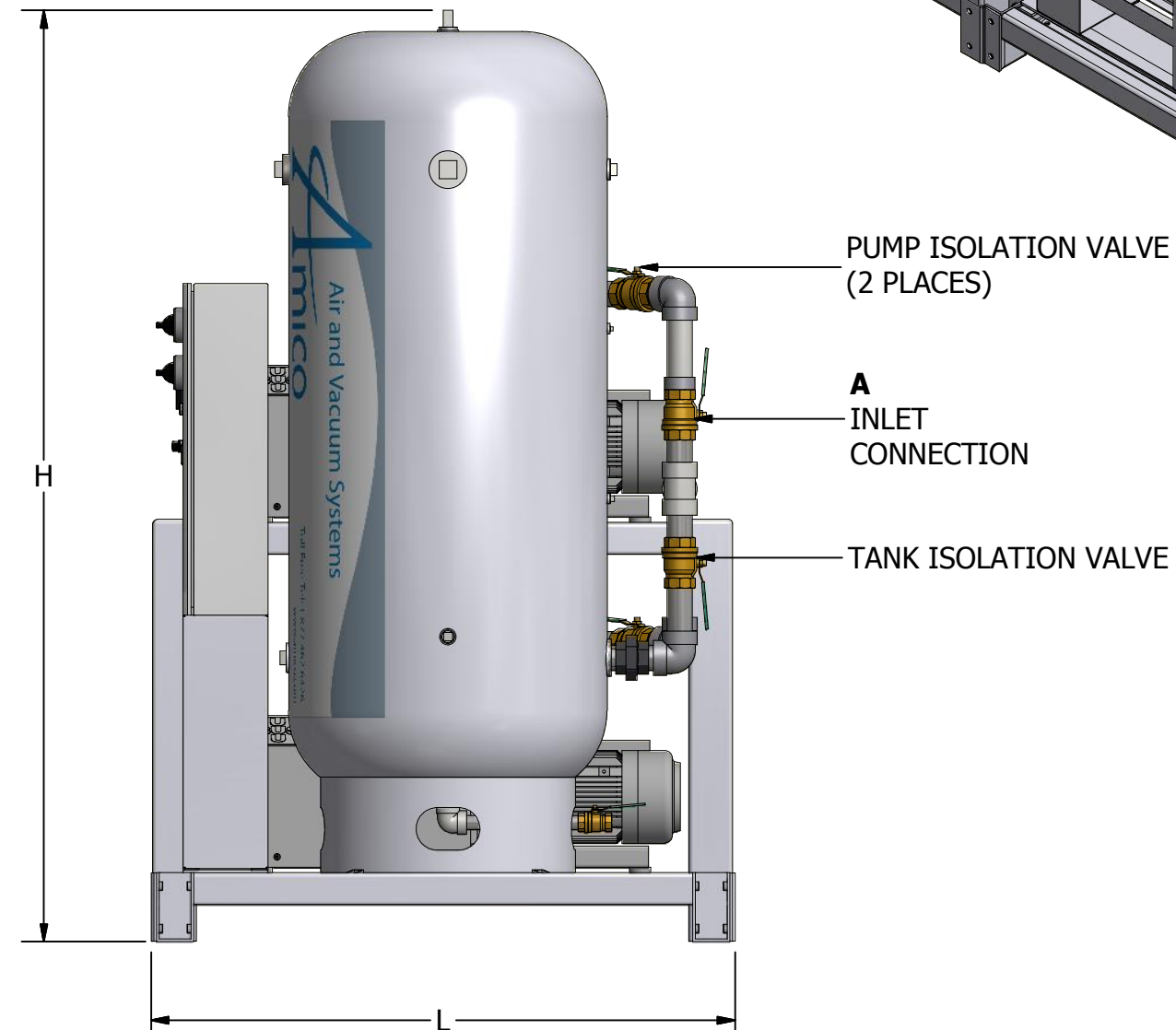
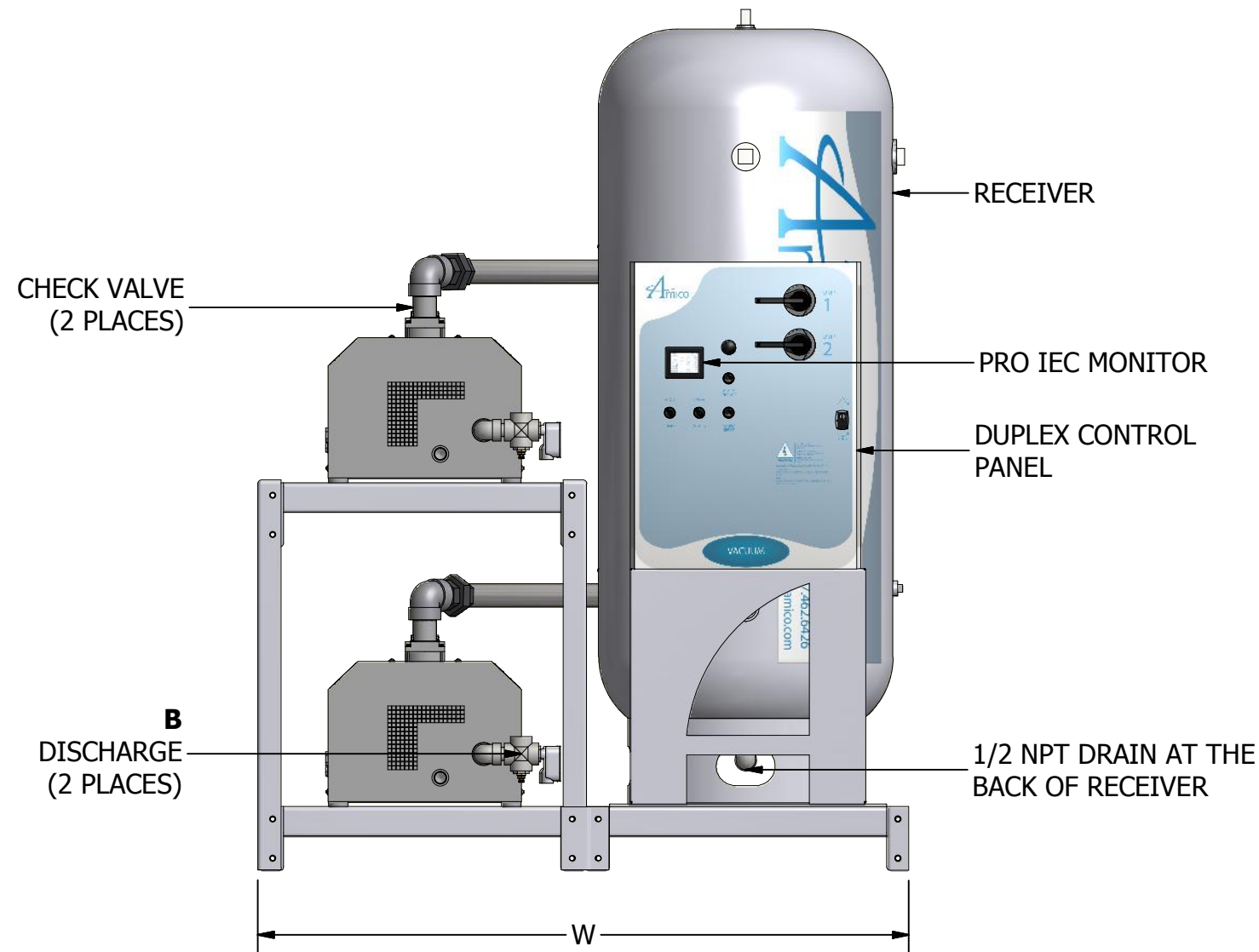
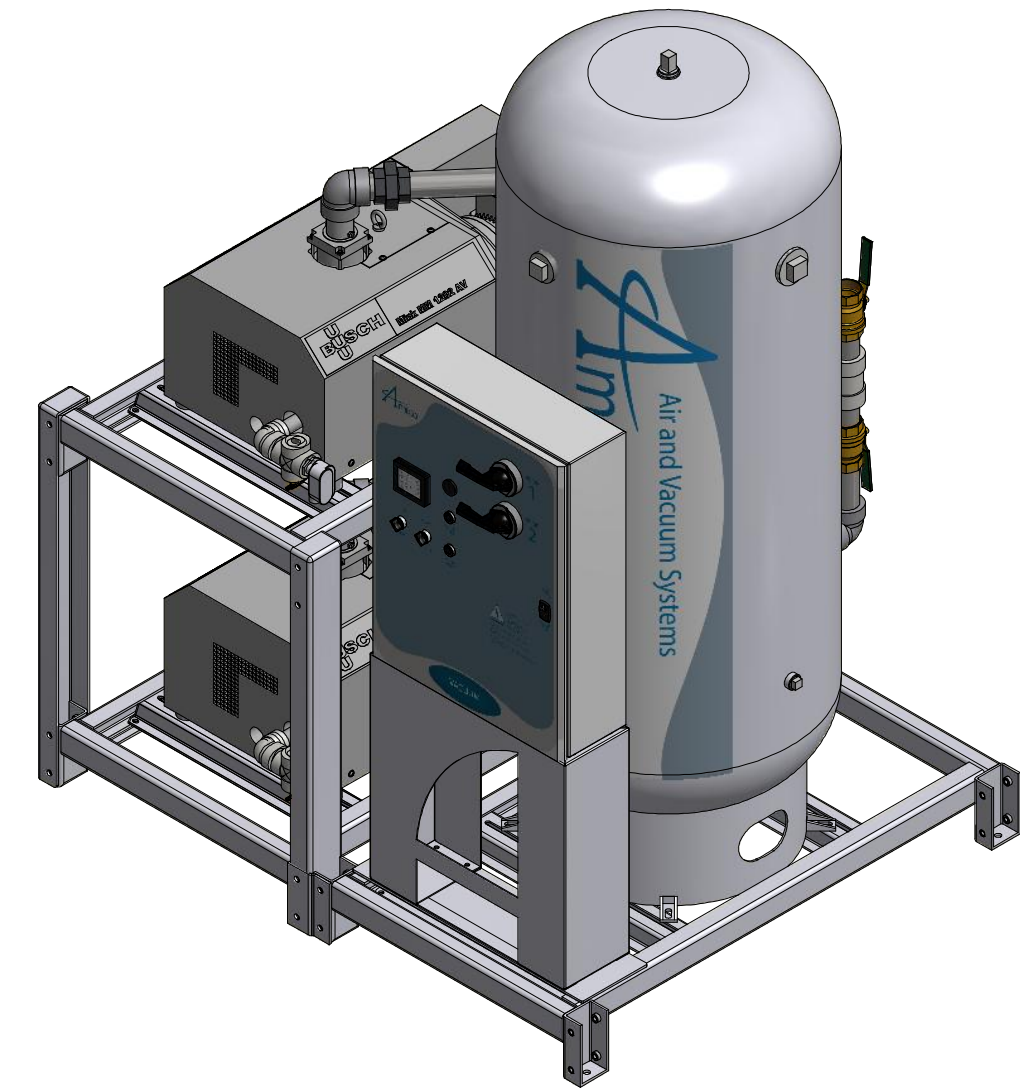
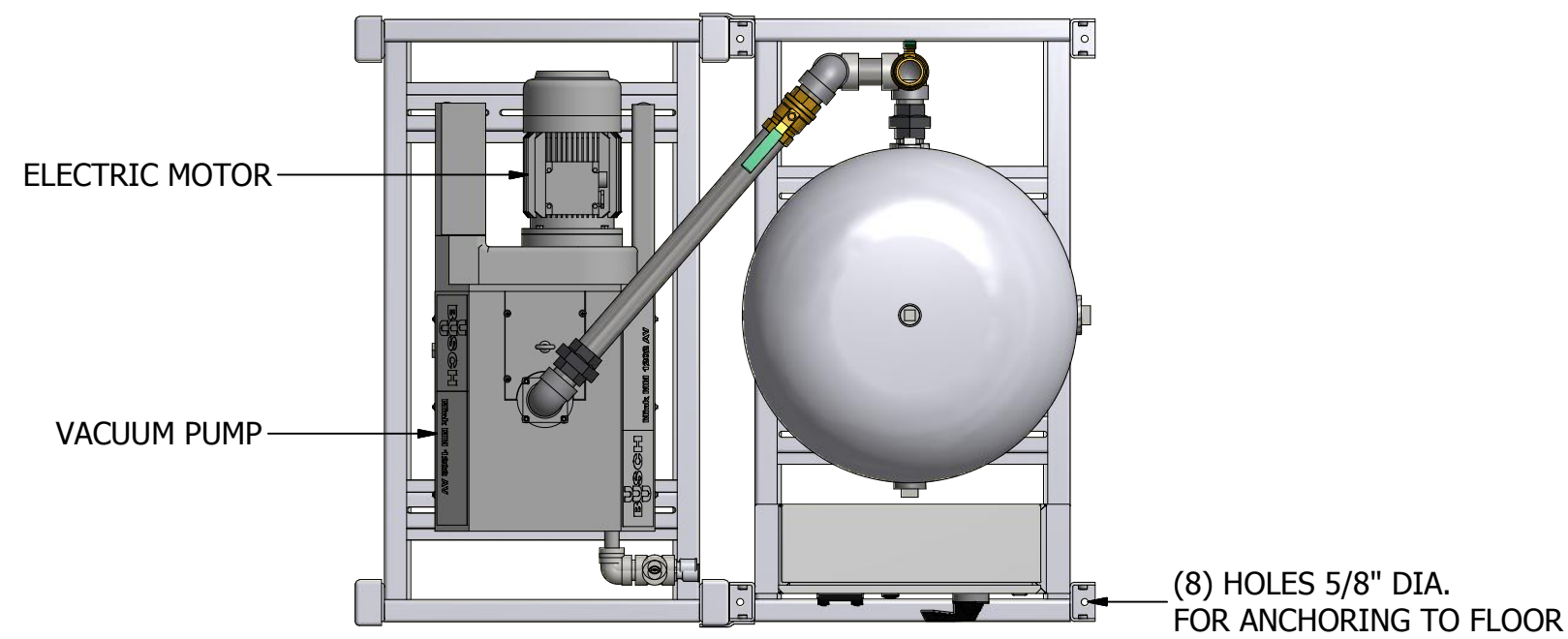

DIMENSIONS SUBJECT TO CHANGE WITHOUT NOTICE

*SYSTEM CONFIGURATION DIFFERS FROM MODEL SHOWN
ADDITIONAL MODELS AVAILABLE UPON REQUEST

MODEL	HP (kW)	A INLET NPT	B OUTLET NPT	TANK SIZE GALLON (LITRE)	PUMP SCFM @ 19" HG (LPM)		NFPA SYSTEM CAPACITIES WITH ONE COMPRESSOR ON STANDBY @ 19" HG (LPM)		WEIGHT IN LBS (KG)	SQ. FT. REQUIRED (M ²)	SYSTEM FLA (WITH ALL COMPRESSORS RUNNING)				SYSTEM BTU/HR	SOUND LEVEL dB (A)	W (M)	L (M)	H (M)
					50 Hz Motor	60 Hz Motor	50 Hz Motor	60 Hz Motor			208V	230V	380V	460V					
V-CCD-D-200P-SS-N-020	2 (1.49)	1.25	1.0	200 (757)	13.3 (378)	16.0 (453)	13.3 (378)	16.0 (453)	2304 (1045)	26.1 (2.41)	14	14	7	7	5,091	70	67 (1.70)	56 (1.42)	91 (2.31)
V-CCD-D-200P-SS-N-030	3 (2.24)	1.25	1.0	200 (757)	17.5 (496)	21.0 (595)	17.5 (496)	21.0 (595)	2326 (1055)	26.1 (2.41)	20	19	10	9	7,636	70	67 (1.70)	56 (1.42)	91 (2.31)
V-CCD-D-200P-SS-N-040	4 (2.98)	1.25	1.0	200 (757)	24.2 (684)	29.0 (821)	24.2 (684)	29.0 (821)	2304 (1045)	26.1 (2.41)	25	23	12	11	10,178	79	67 (1.70)	56 (1.42)	91 (2.31)
V-CCD-D-200P-SS-N-054	5.4 (4.03)	1.25	1.0	200 (757)	31.7 (897)	38.0 (1076)	31.7 (897)	38.0 (1076)	2326 (1055)	26.1 (2.41)	34	30	17	15	13,740	79	67 (1.70)	56 (1.42)	91 (2.31)
V-CCD-D-200P-SS-N-064	6.4 (4.77)	2.0	1.0	200 (757)	43.3 (1227)	52.0 (1472)	43.3 (1227)	52.0 (1472)	2574 (1168)	26.1 (2.41)	37	35	19	17	16,284	79	67 (1.70)	56 (1.42)	91 (2.31)
V-CCD-D-200P-SS-N-075	7.5 (5.59)	2.0	1.0	200 (757)	54.2 (1534)	65.0 (1841)	54.2 (1534)	65.0 (1841)	2596 (1178)	26.1 (2.41)	48	45	24	23	19,091	79	67 (1.70)	56 (1.42)	91 (2.31)
V-CCD-D-200P-SS-N-100	10 (7.46)	3.0	2.0	200 (757)	91.7 (2597)	110.0 (3115)	91.7 (2597)	110.0 (3115)	3000 (1361)	30.2 (2.81)	54	48	-	24	25,455	83	67 (1.70)	65 (1.65)	91 (2.31)
V-CCD-D-200P-SS-N-150	15 (11.2)	3.0	2.0	200 (757)	107.5 (3044)	129.0 (3653)	107.5 (3044)	129.0 (3653)	3022 (1371)	34.9 (3.24)	79	70	-	35	38,182	82	67 (1.70)	75 (1.91)	91 (2.31)
V-CCD-D-200P-SS-N-300*	30 (22.4)	4.0	4.0	200 (757)	179.4 (5081)	215.3 (6097)	179.4 (5081)	215.3 (6097)	5153 (2337)	66.7 (6.19)	160	144	92	72	76,333	83	120 (3.05)	80 (2.03)	92 (2.34)



85 Fulton Way, Richmond Hill
Ontario, L4B 2N4 Canada
71 East Industry Court
Deer Park, NY 11729
Direct Tel: 905.764.0800
Tel: 1.877.462.6426
Fax: 1.866.440.4986

CONTACTLESS CLAW - DRY DUPLEX "SPACE SAVER" VACUUM SYSTEM (2.0 HP - 10.0 HP)

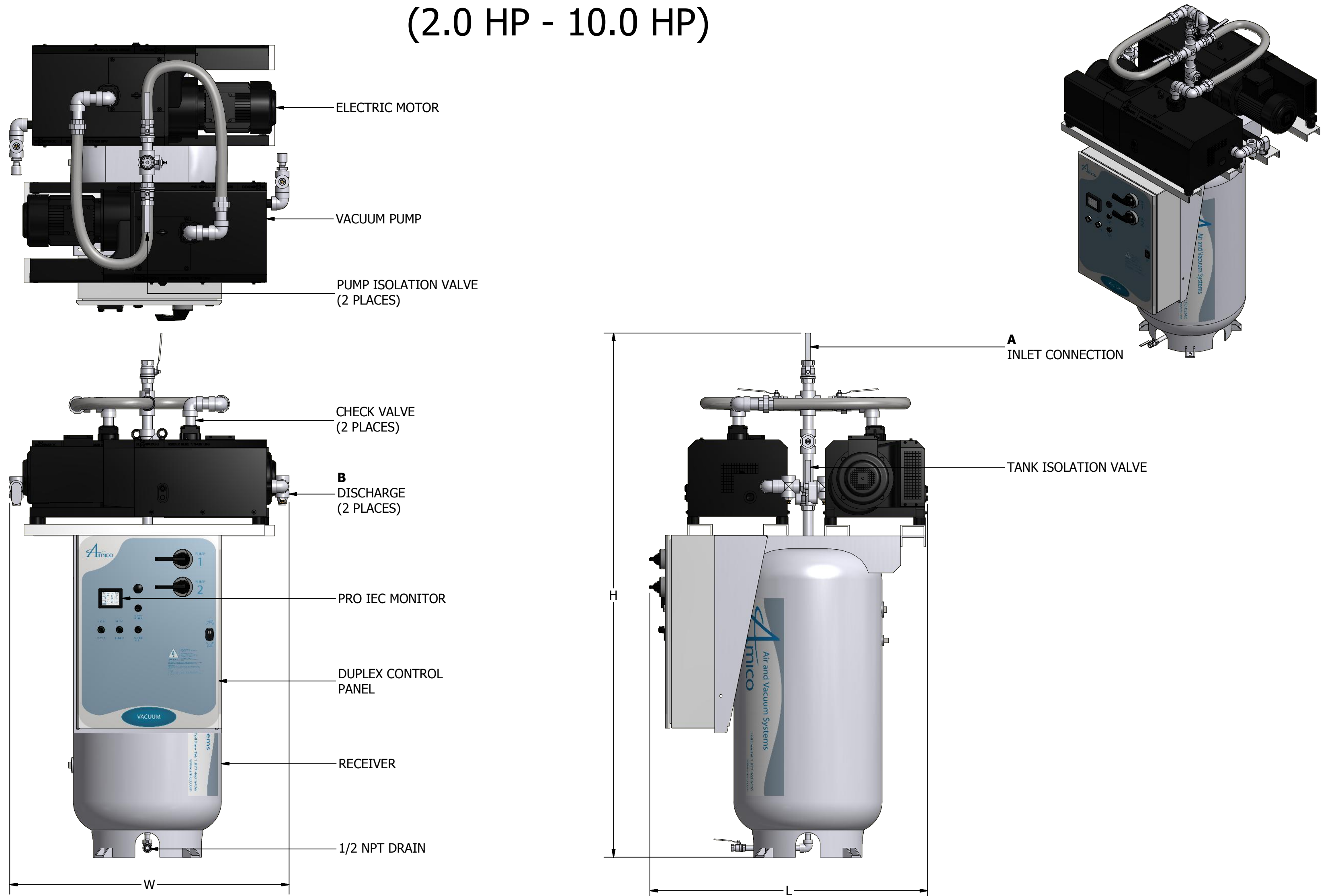

DIMENSIONS SUBJECT TO CHANGE WITHOUT NOTICE

ADDITIONAL MODELS AVAILABLE UPON REQUEST

MODEL	HP (KW)	A INLET NPT	B OUTLET NPT	TANK SIZE GALLON (LITRE)	PUMP SCFM @ 19" HG (LPM)		NFPA SYSTEM CAPACITIES WITH ONE COMPRESSOR ON STANDBY @ 19" HG (LPM)		WEIGHT IN LBS (KG)	SQ. FT. REQUIRED (M ²)	SYSTEM FLA (WITH ALL COMPRESSORS RUNNING)				SYSTEM BTU/HR	SOUND LEVEL dB (A)	W (M)	L (M)	H (M)
					50 Hz Motor	60 Hz Motor	50 Hz Motor	60 Hz Motor			208V	230V	380V	460V					
					V-CCD-D-080P-TS-N-020	2 (1.49)	1.25	1.0			80 (303)	13.3 (378)	16.0 (453)	13.3 (378)					
V-CCD-D-080P-TS-N-030	3 (2.24)	1.25	1.0	80 (303)	17.5 (496)	21.0 (595)	17.5 (496)	21.0 (595)	1601 (726)	19.9 (1.85)	20	19	10	9	7,636	70	55 (1.40)	52 (1.32)	92 (2.34)
V-CCD-D-080P-TS-N-040	4 (2.98)	1.25	1.0	80 (303)	24.2 (684)	29.0 (821)	24.2 (684)	29.0 (821)	1579 (716)	19.9 (1.85)	25	23	12	11	10,178	79	55 (1.40)	52 (1.32)	92 (2.34)
V-CCD-D-080P-TS-N-054	5.4 (4.03)	1.25	1.0	80 (303)	31.7 (897)	38.0 (1076)	31.7 (897)	38.0 (1076)	1601 (726)	19.9 (1.85)	34	30	17	15	13,740	79	55 (1.40)	52 (1.32)	92 (2.34)
V-CCD-D-120P-TS-N-064	6.4 (4.77)	2.0	1.0	120 (454)	43.3 (1227)	52.0 (1472)	43.3 (1227)	52.0 (1472)	2007 (910)	23.0 (2.13)	37	35	19	17	16,284	79	57 (1.45)	58 (1.47)	95 (2.41)
V-CCD-D-120P-TS-N-075	7.5 (5.59)	2.0	1.0	120 (454)	54.2 (1534)	65.0 (1841)	54.2 (1534)	65.0 (1841)	2029 (920)	23.0 (2.13)	48	45	24	23	19,091	79	57 (1.45)	58 (1.47)	95 (2.41)
V-CCD-D-120P-TS-N-100	10 (7.46)	2.0	1.25	120 (454)	60.8 (1723)	73.0 (2067)	60.8 (1723)	73.0 (2067)	2233 (1013)	23.0 (2.13)	54	50	28	25	25,455	82	57 (1.45)	58 (1.47)	95 (2.41)



85 Fulton Way, Richmond Hill
Ontario, L4B 2N4 Canada
71 East Industry Court
Deer Park, NY 11729
Direct Tel: 905.764.0800
Tel: 1.877.462.6426
Fax: 1.866.440.4986

CONTACTLESS CLAW - DRY QUADRAPLEX STACK MOUNTED VACUUM SYSTEM (2.0 HP - 30.0 HP)

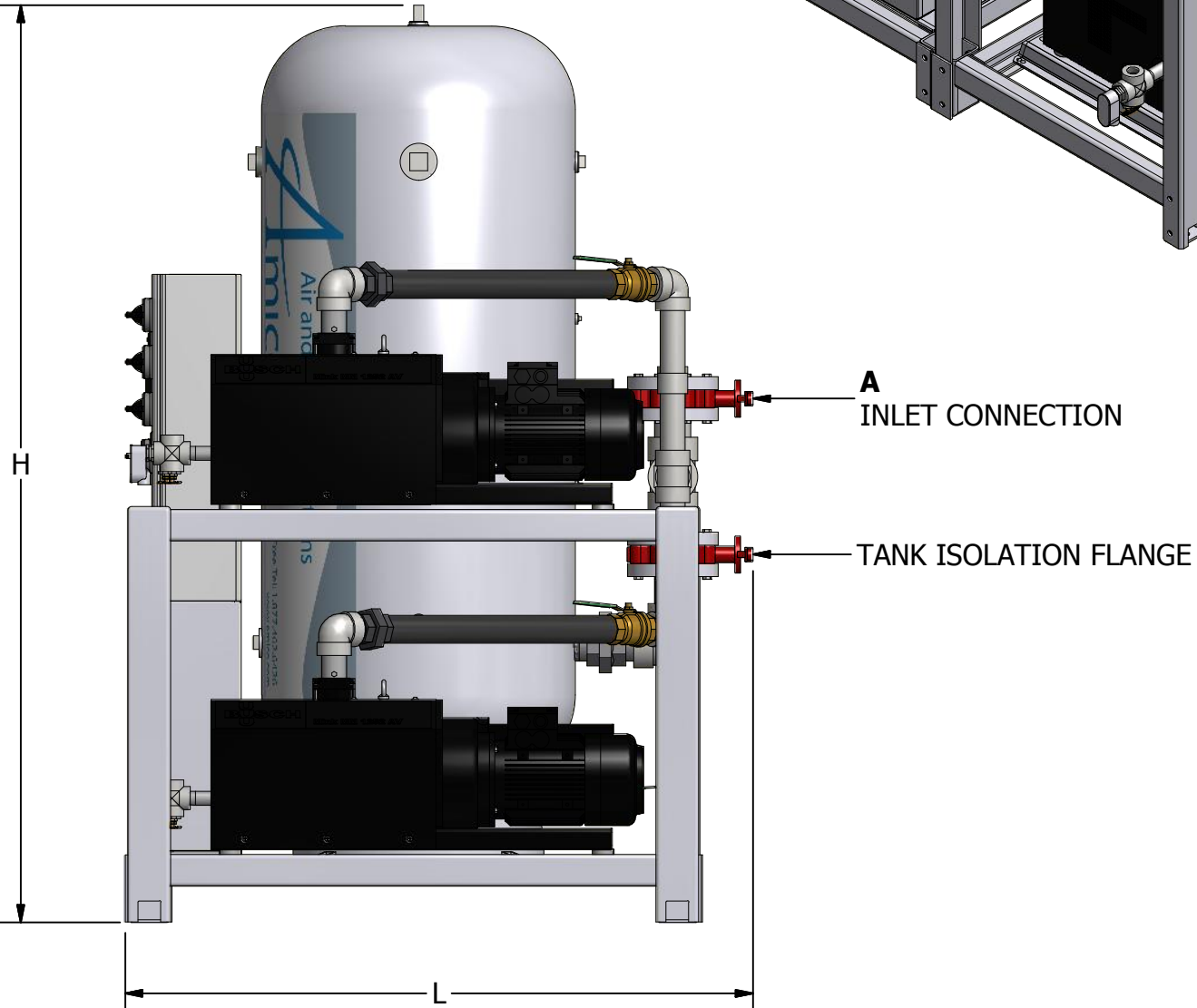
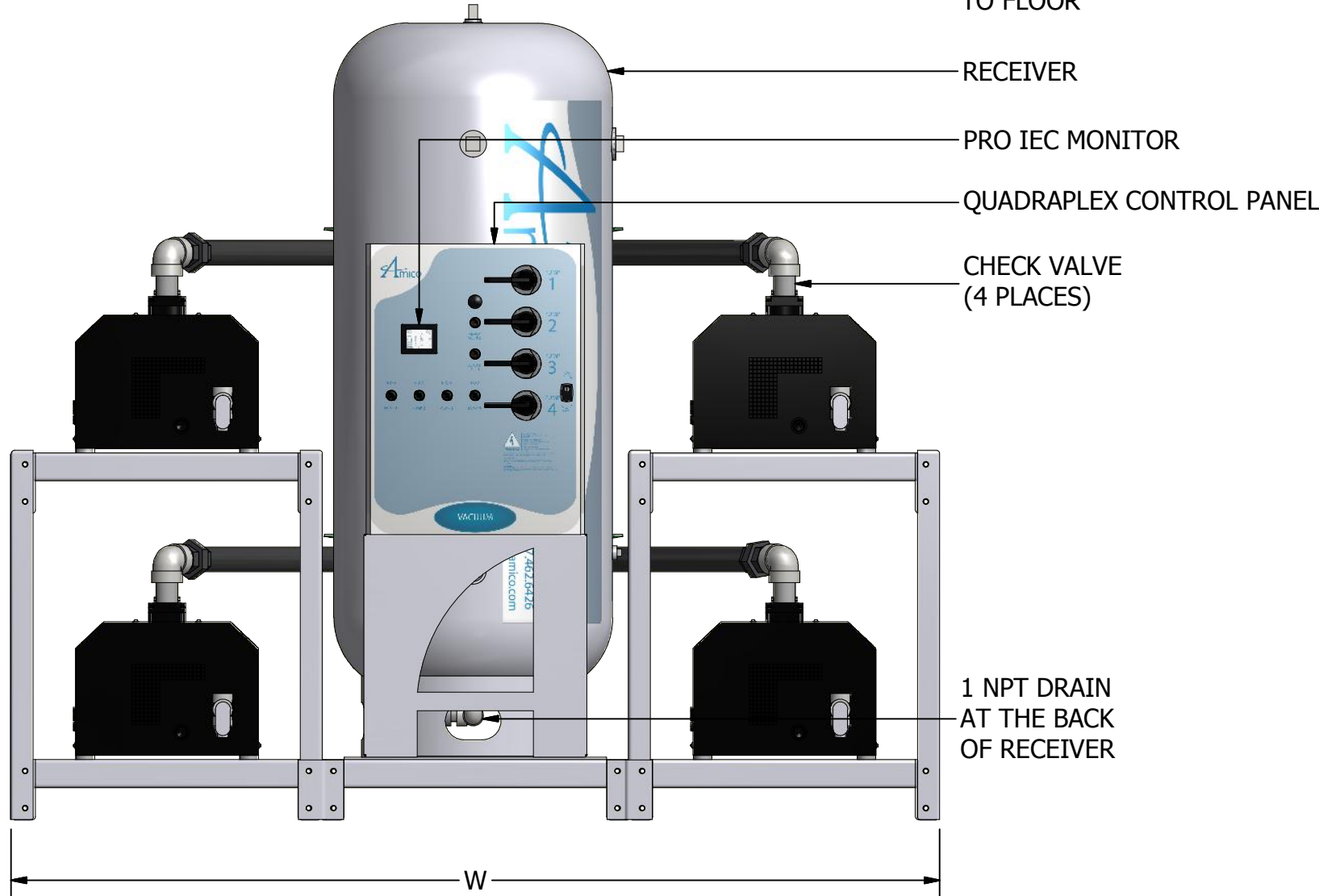
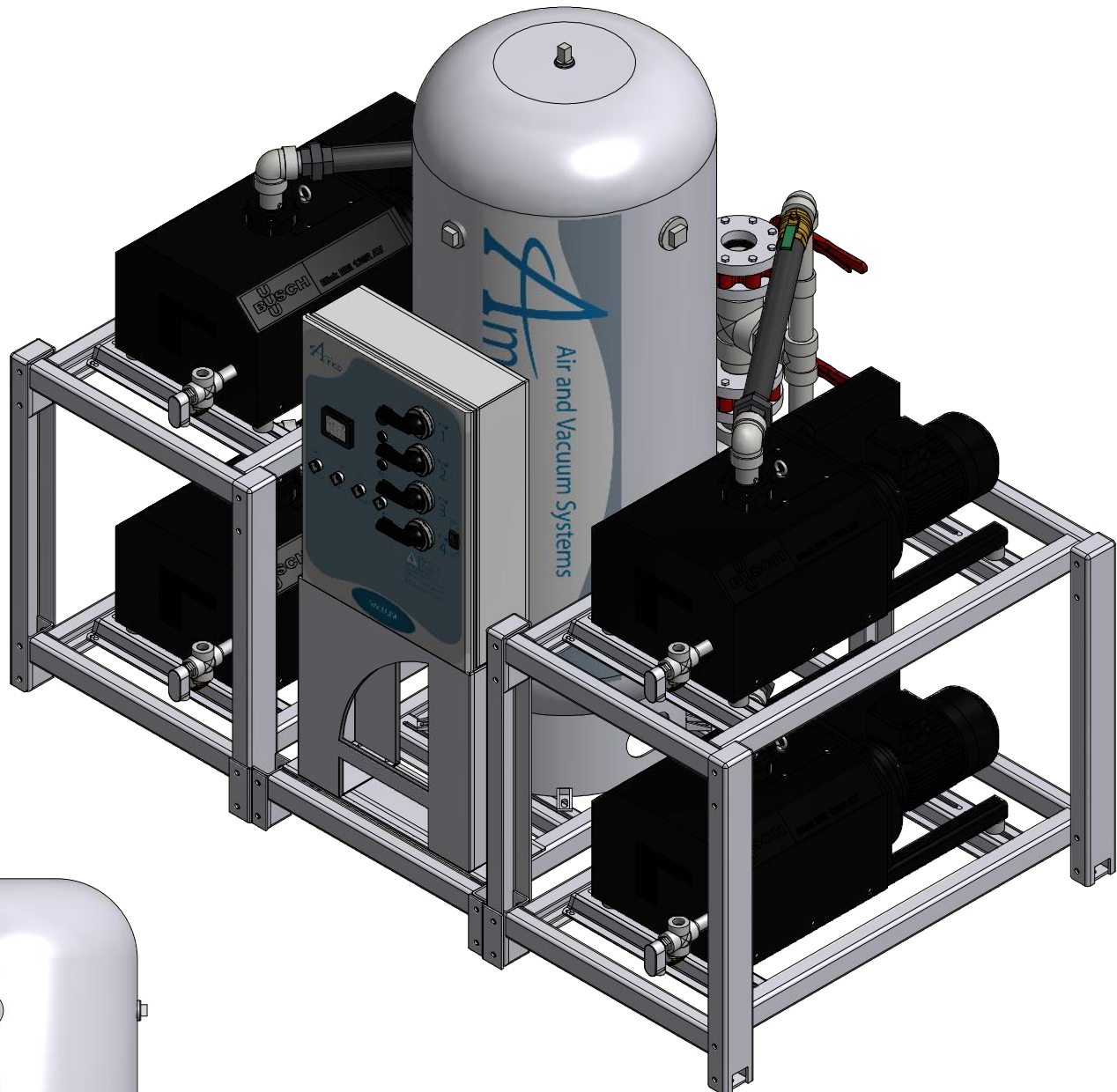
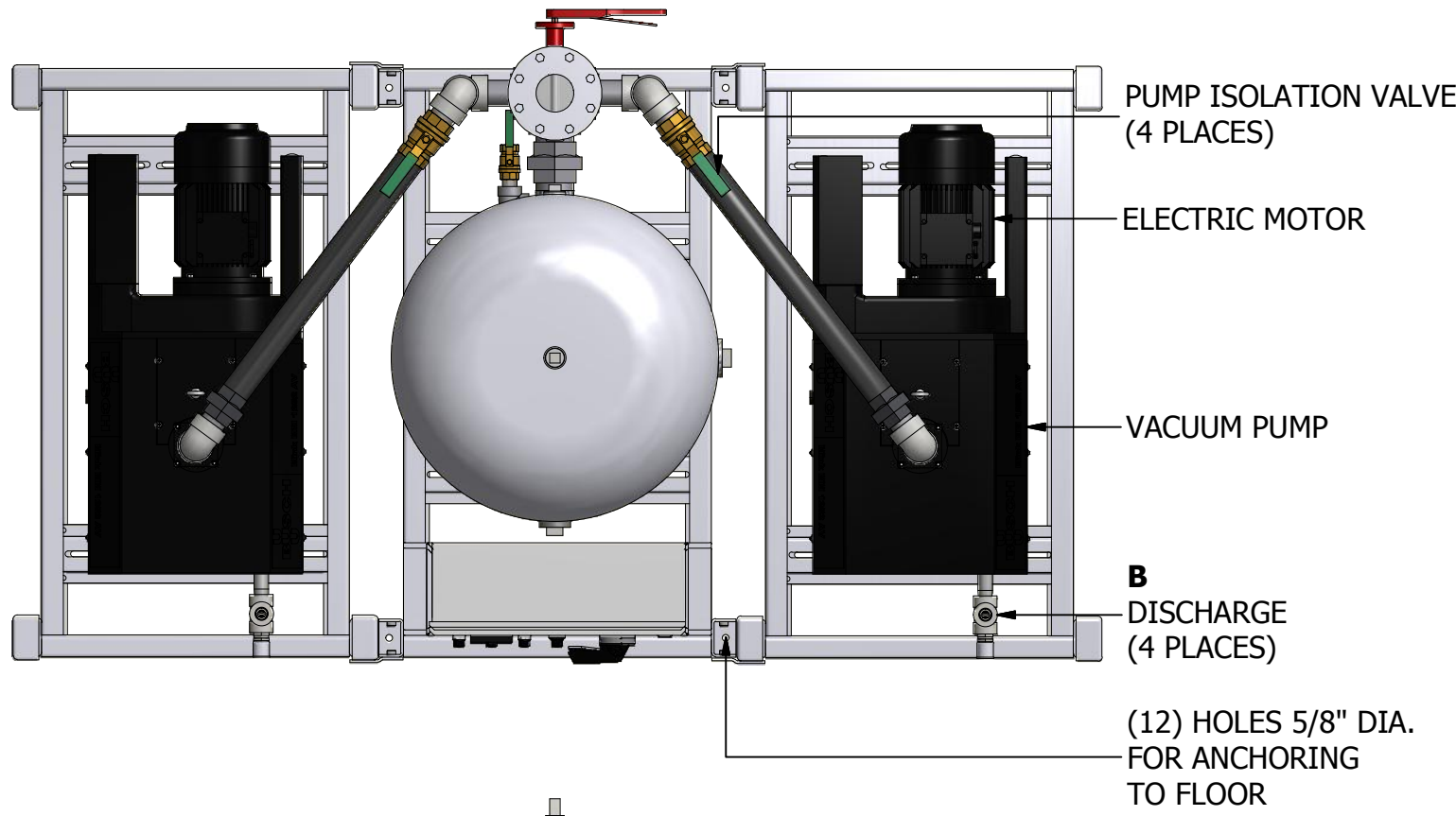

DIMENSIONS SUBJECT TO CHANGE WITHOUT NOTICE

MODEL	HP (kW)	A INLET NPT	B OUTLET NPT	TANK SIZE GALLON (LITRE)	PUMP SCFM @ 19" HG (LPM)		NFPA SYSTEM CAPACITIES WITH ONE COMPRESSOR ON STANDBY @ 19" HG (LPM)		WEIGHT IN LBS (KG)	SQ. FT. REQUIRED (M ²)	SYSTEM FLA (WITH ALL COMPRESSORS RUNNING)				SYSTEM BTU/HR	SOUND LEVEL dB (A)	W (M)	L (M)	H (M)
					50 Hz Motor	60 Hz Motor	50 Hz Motor	60 Hz Motor			208V	230V	380V	460V					
V-CCD-Q-200P-SS-N-020	2 (1.49)	2.0	1.0	200 (757)	13.3 (378)	16.0 (453)	40.0 (1133)	48.0 (1359)	3551 (1611)	39.3 (3.65)	29	27	14	14	15,273	75	101 (2.57)	56 (1.42)	95 (2.41)
V-CCD-Q-200P-SS-N-030	3 (2.24)	2.0	1.0	200 (757)	17.5 (496)	21.0 (595)	52.5 (1487)	63.0 (1784)	3595 (1631)	39.3 (3.65)	39	38	20	19	22,908	75	101 (2.57)	56 (1.42)	95 (2.41)
V-CCD-Q-200P-SS-N-040	4 (2.98)	2.0	1.0	200 (757)	24.2 (684)	29.0 (821)	72.5 (2053)	87.0 (2464)	3551 (1611)	39.3 (3.65)	50	46	25	23	30,534	84	101 (2.57)	56 (1.42)	95 (2.41)
V-CCD-Q-200P-SS-N-054	5.4 (4.03)	2.0	1.0	200 (757)	31.7 (897)	38.0 (1076)	95.0 (2690)	114.0 (3228)	3595 (1631)	39.3 (3.65)	68	60	34	30	41,220	84	101 (2.57)	56 (1.42)	97 (2.46)
V-CCD-Q-200P-SS-N-064	6.4 (4.77)	4.0	1.0	200 (757)	43.3 (1227)	52.0 (1472)	130.0 (3681)	156.0 (4417)	4041 (1833)	45.6 (4.24)	74	70	37	35	48,852	84	101 (2.57)	65 (1.65)	97 (2.46)
V-CCD-Q-200P-SS-N-075	7.5 (5.59)	4.0	1.0	200 (757)	54.2 (1534)	65.0 (1841)	162.5 (4601)	195.0 (5522)	4085 (1853)	45.6 (4.24)	95	90	48	45	57,273	84	101 (2.57)	65 (1.65)	97 (2.46)
V-CCD-Q-200P-SS-N-100	10 (7.46)	5.0	2.0	200 (757)	91.7 (2597)	110.0 (3115)	275.0 (7787)	330.0 (9345)	4887 (2217)	49.1 (4.57)	107	95	-	48	76,365	88	101 (2.57)	70 (1.78)	91 (2.31)
V-CCD-Q-200P-SS-N-150	15 (11.2)	5.0	2.0	200 (757)	107.5 (3044)	129.0 (3653)	322.5 (9132)	387.0 (10959)	5819 (2639)	52.6 (4.91)	158	140	-	70	114,546	87	101 (2.57)	75 (1.91)	91 (2.31)
V-CCD-Q-200P-SS-N-300*	30 (22.4)	6.0	4.0	200 (757)	179.4 (5081)	215.3 (6097)	538.3 (15242)	645.9 (18290)	9061 (4110)	111.1 (10.3)	320	288	183	144	228,999	88	200 (5.08)	80 (2.03)	92 (2.34)

*SYSTEM CONFIGURATION DIFFERS FROM MODEL SHOWN

ADDITIONAL MODELS AVAILABLE UPON REQUEST



85 Fulton Way, Richmond Hill
Ontario, L4B 2N4 Canada
71 East Industry Court
Deer Park, NY 11729
Direct Tel: 905.764.0800
Tel: 1.877.462.6426
Fax: 1.866.440.4986

CONTACTLESS CLAW - DRY TRIPLEX STACK MOUNTED VACUUM SYSTEM (2.0 HP - 30.0 HP)

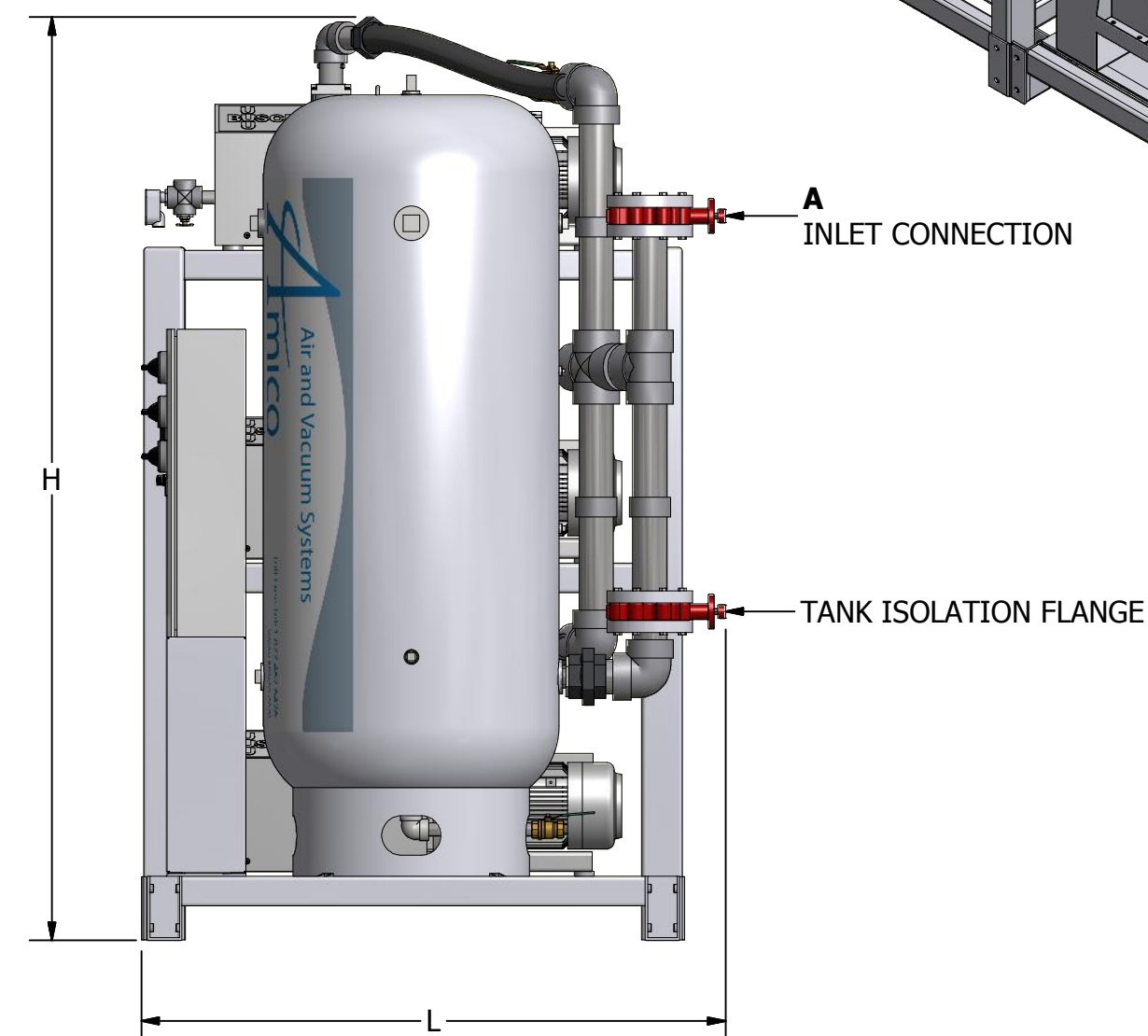
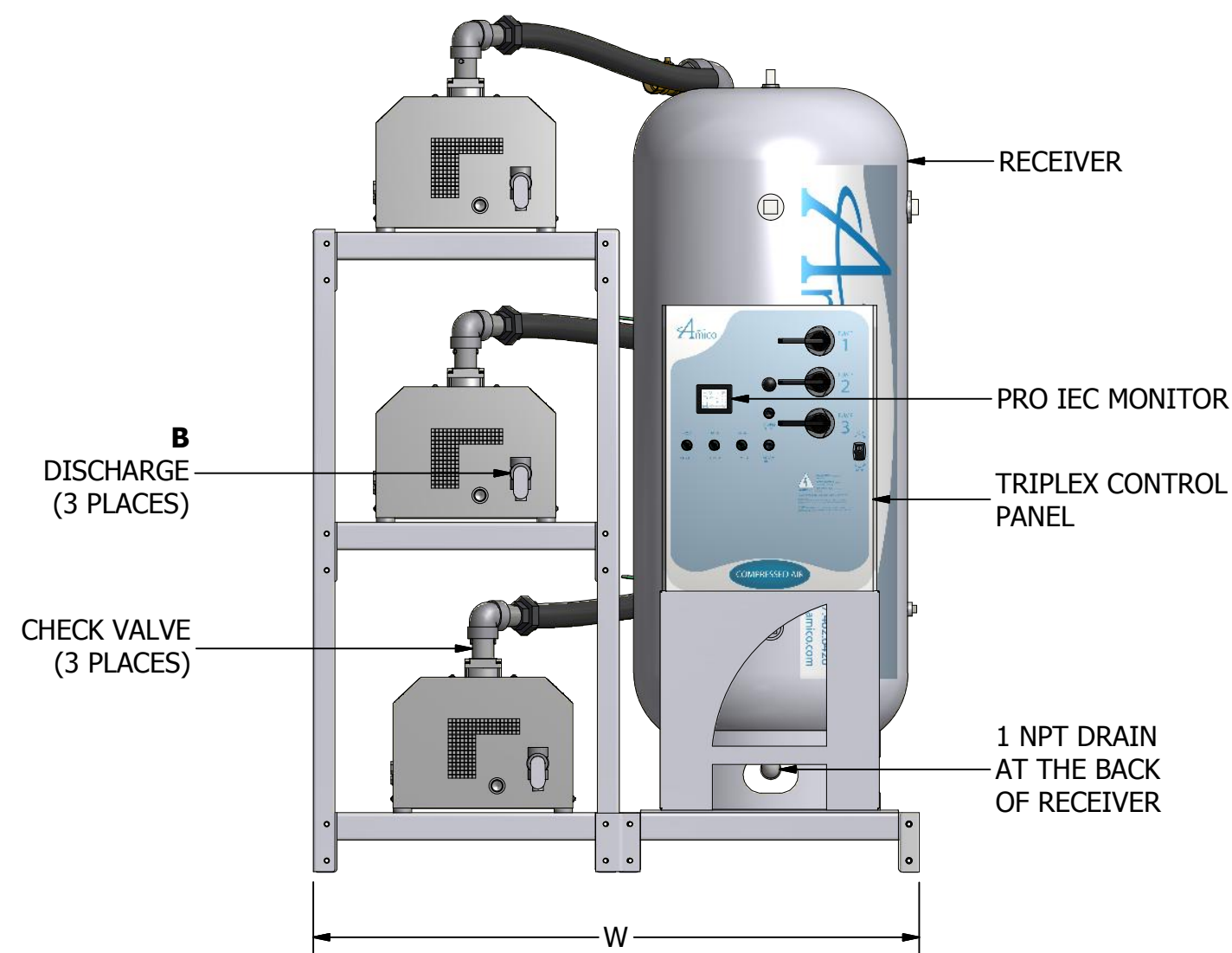
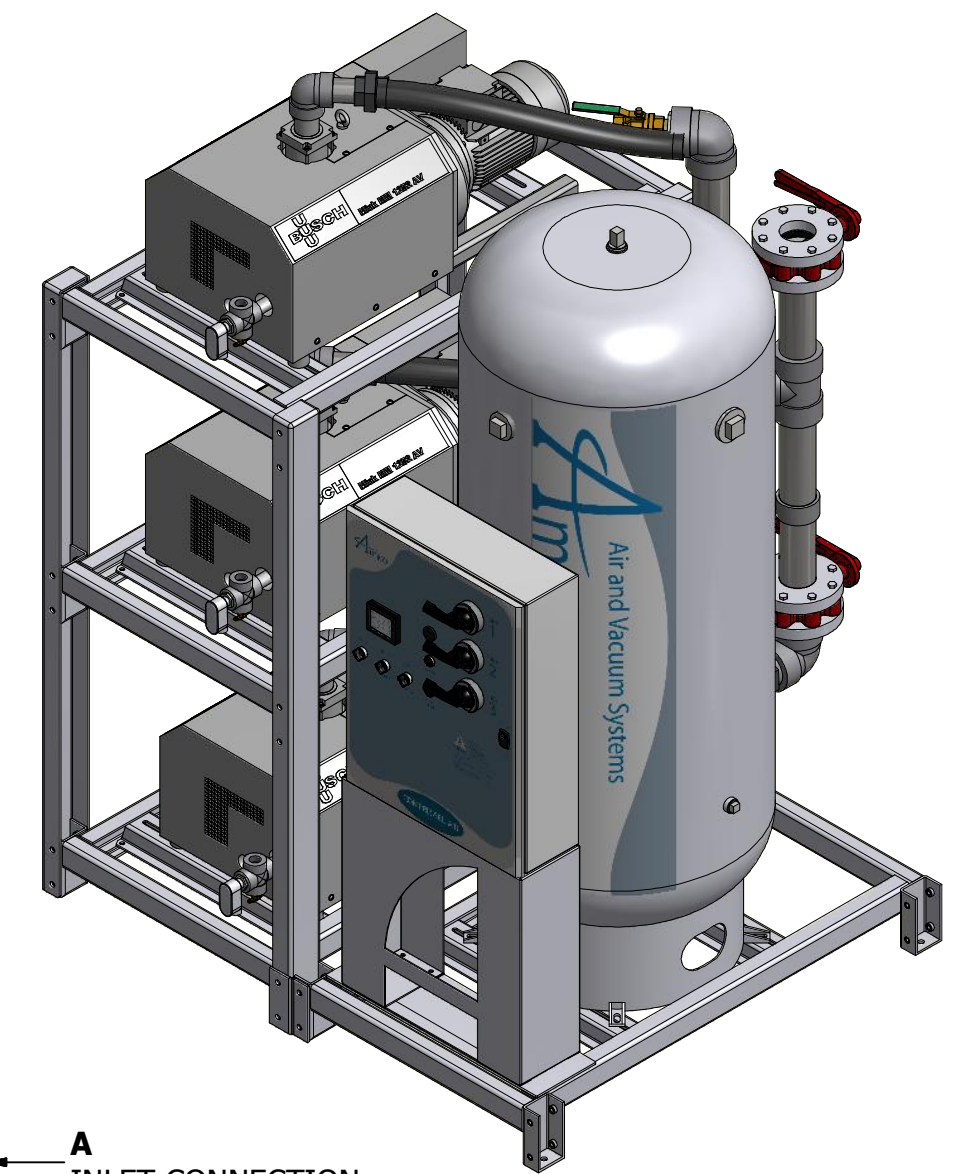
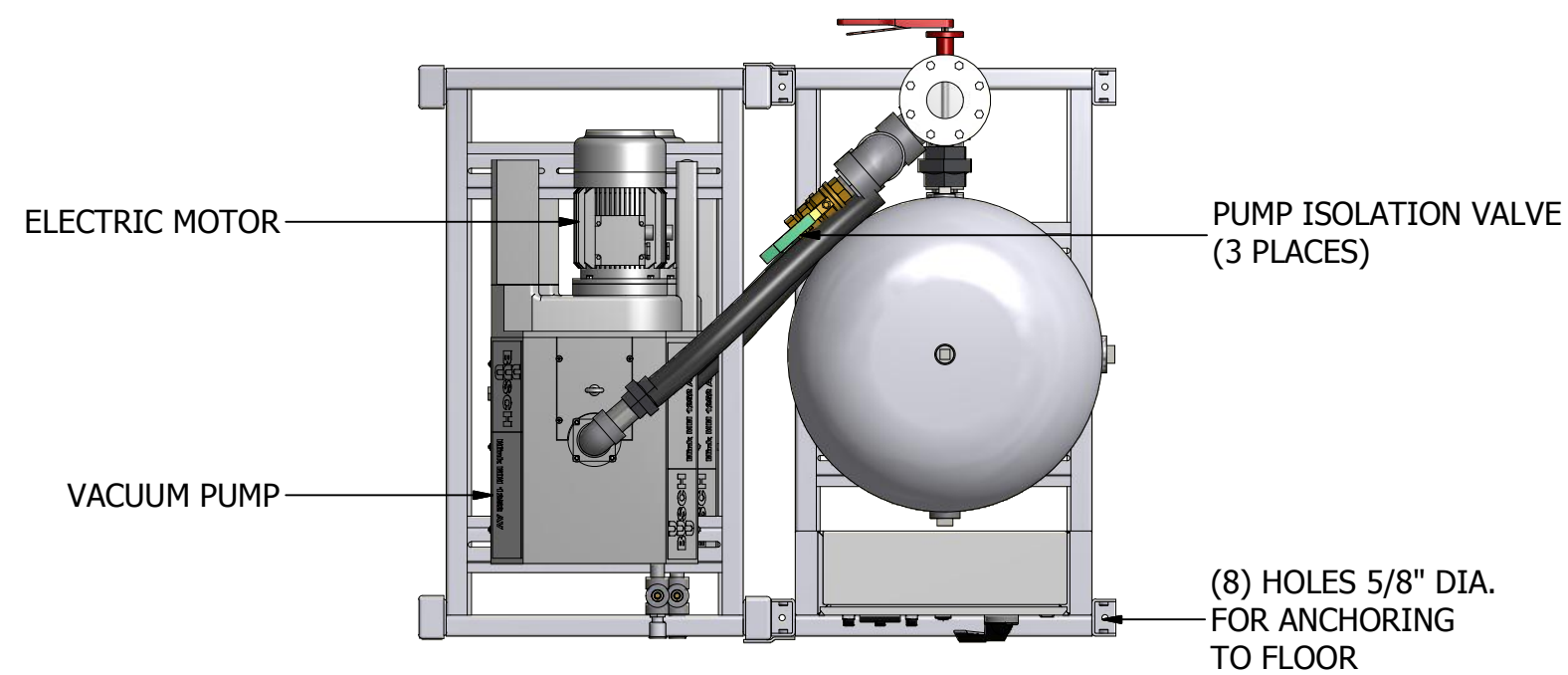

DIMENSIONS SUBJECT TO CHANGE WITHOUT NOTICE

MODEL	HP (kW)	A INLET NPT	B OUTLET NPT	TANK SIZE GALLON (LITRE)	PUMP SCFM @ 19" HG (LPM)		NFPA SYSTEM CAPACITIES WITH ONE COMPRESSOR ON STANDBY @ 19" HG (LPM)		WEIGHT IN LBS (KG)	SQ. FT. REQUIRED (M ²)	SYSTEM FLA (WITH ALL COMPRESSORS RUNNING)				SYSTEM BTU/HR	SOUND LEVEL dB (A)	W (M)	L (M)	H (M)
					50 Hz Motor	60 Hz Motor	50 Hz Motor	60 Hz Motor			208V	230V	380V	460V					
					V-CCD-T-200P-SS-N-020	2 (1.49)	1.5	1.0			200 (757)	13.3 (378)	16.0 (453)	26.7 (755)					
V-CCD-T-200P-SS-N-030	3 (2.24)	1.5	1.0	200 (757)	17.5 (496)	21.0 (595)	35 (991)	42.0 (1189)	2972 (1348)	26.1 (2.41)	29	28	15	14	15,272	73	67 (1.70)	56 (1.42)	95 (2.41)
V-CCD-T-200P-SS-N-040	4 (2.98)	1.5	1.0	200 (757)	24.2 (684)	29.0 (821)	48.3 (1369)	58.0 (1642)	2939 (1333)	26.1 (2.41)	37	34	19	17	20,356	82	67 (1.70)	56 (1.42)	95 (2.41)
V-CCD-T-200P-SS-N-054	5.4 (4.03)	1.5	1.0	200 (757)	31.7 (897)	38.0 (1076)	63.3 (1793)	76.0 (2152)	2972 (1348)	26.1 (2.41)	51	45	26	23	27,480	82	67 (1.70)	56 (1.42)	97 (2.46)
V-CCD-T-200P-SS-N-064	6.4 (4.77)	3.0	1.0	200 (757)	43.3 (1227)	52.0 (1472)	86.7 (2454)	104.0 (2945)	3319 (1505)	30.2 (2.81)	56	52	28	26	32,568	82	67 (1.70)	65 (1.65)	97 (2.46)
V-CCD-T-200P-SS-N-075	7.5 (5.59)	3.0	1.0	200 (757)	54.2 (1534)	65.0 (1841)	108.3 (3068)	130.0 (3681)	3352 (1320)	30.2 (2.81)	71	68	36	34	38,182	82	67 (1.70)	65 (1.65)	97 (2.46)
V-CCD-T-200P-SS-N-100	10 (7.46)	4.0	2.0	200 (757)	91.7 (2597)	110.0 (3115)	183.4 (5193)	220.0 (6230)	3933 (1784)	48.6 (4.52)	80	71	-	36	50,910	86	100 (2.54)	70 (1.78)	91 (2.31)
V-CCD-T-200P-SS-N-150	15 (11.2)	4.0	2.0	200 (757)	107.5 (3044)	129.0 (3653)	215 (6088)	258.0 (7306)	3966 (1799)	52.1 (4.84)	119	105	-	53	76,364	85	100 (2.54)	75 (1.91)	91 (2.31)
V-CCD-T-200P-SS-N-300*	30 (22.4)	5.0	4.0	200 (757)	179.4 (5081)	215.3 (6097)	358.8 (10161)	430.6 (12193)	7092 (3217)	88.9 (8.24)	240	216	137	108	152,666	86	160 (4.06)	80 (2.03)	92 (2.34)

*SYSTEM CONFIGURATION DIFFERS FROM MODEL SHOWN

ADDITIONAL MODELS AVAILABLE UPON REQUEST



85 Fulton Way, Richmond Hill
Ontario, L4B 2N4 Canada
71 East Industry Court
Deer Park, NY 11729
Direct Tel: 905.764.0800
Tel: 1.877.462.6426
Fax: 1.866.440.4986