

Installation Instructions

ARS (Amico Rail Systems)



Preface

Important, Please Read Carefully

Thank you for your purchase with Amico Accessories Inc.

This unit is designed for long lasting performance, providing the end user complies with assembly and maintenance procedures. This Instruction Manual is your guide to ensure that you get the best performance out of the equipment. Amico Accessories Inc. is not responsible for any damage as a result of **(but not limited to)** abuse and other problems that may be a direct or indirect result of failure to comply with the instructions provided in this manual.

The tools used in this manual are either imperial or metric. Any metric conversions included for imperial measurements are approximate and may be omitted if only imperial tools and/or hardware are compatible.

Please Note These Key Words and Symbols:



WARNING

Steps where extra care should be taken to prevent injuries and damage.



NOTE

Steps that point out helpful information.

Medical Facility Responsibilities

Preventive maintenance checks must be performed regularly to maintain the quality and performance of this product. Any parts that may be broken, missing, worn, distorted or contaminated in any way should not be used and all affected parts should be replaced immediately. Should the necessity of any repair be suspected, please contact your local distributor or call 877.264.2697.

Table of Contents

Section 1: Product Specifications

Features 3

Section 2: Installation Preparation

Installation Tools and Parts Required 3

Pre-Installation Information 4

Section 3: Installation on Mounting Platform

Instructions for Installation 5

ARS/VRS Mounting 6

Section 4: Device Installation

6

Section 5: Maintenance, Troubleshooting and Product Classification

Troubleshooting 7

Preventive Maintenance 7

Cleaning 8

Warranty

9

Section 1: Product Specifications

Features

Amico Accessories Inc. Horizontal Rails are an integral part of equipment management systems used to improve ergonomics and room efficiency for healthcare providers. With direct wall mount capabilities, horizontal use of space and vertical mounting options you are guaranteed to cover all angles for your mounting solutions.

ARS (Amico Horizontal Rail System)

1. Integrated mounting plate
2. Negative profile allows for ease of maintenance and infection control
3. Designed for horizontal applications
4. Direct wall mount and vertical rail mounting options
5. Available in a wide variety of lengths

Section 2: Installation Preparation

Installation Tools and Parts Required

 **NOTE:** Amico Accessories Inc. does not provide any tools or hardware necessary for installation.

Wall Mount:

ARS Bracket, ARS Rail, Sheet Metal Screws, Pan Head Machine Screws

 **NOTE:** Amount of screws varies depending on channel length.

Vertical Rail Mounting:

ARS Bracket, ARS Rail, Vertical Rail, (2) BASK-VTRK-X Adapters

Section 2: Installation Preparation

Pre-Installation Information (PLEASE READ CAREFULLY BEFORE STARTING)

Although considerable effort has been made in this manual to ensure safety, the installation itself is beyond the control of Amico Accessories Inc. Accordingly, Amico Accessories Inc. will not be responsible for the failure of any such installation.

⚠ WARNING: It shall be the responsibility of the hospital, its consultants and/or contractors to determine that the wall is adequate to safely mount the specific instrument. This includes the selection of appropriate fasteners and proper installation. The following is guideline information only. See rail instructions for specific wall channel guideline information.

FOR OTHER WALL BACKINGS NOT SPECIFIED IN THIS MANUAL:

Contact your structural engineer or contact Amico Accessories Inc. to discuss solutions.

Section 3: Installation on Mounting Platform

Instructions for Installation

1. To mount the center of the rail channel at distance X from the floor, insert hardware through the rail bracket at distance $X+0.0375$ " ($X+ 0.9525$ mm) from the floor as shown below.

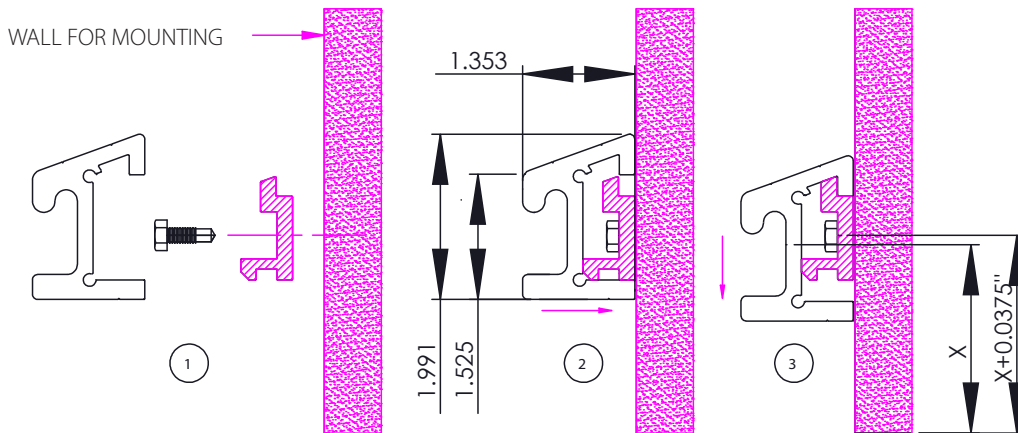

2. Remove the rail bracket from the rail channel by loosening the set screws on the bottom of the rail channel and sliding the rail bracket out.
3. Using the ID mark on the bracket, drill holes approximately 2.5" (6.35 cm) from ends, maximum 16" (40.64 cm) apart.
4. Ensure there is adequate structural support for the planned usage of the rail. Determine hardware necessary for installation and confirm hardware spacing by consulting with engineers on the specific wall construction and building codes.
5. After mounting the bracket to the wall, attach the rail channel as shown below. Tighten the set screws and ensure everything is secure.

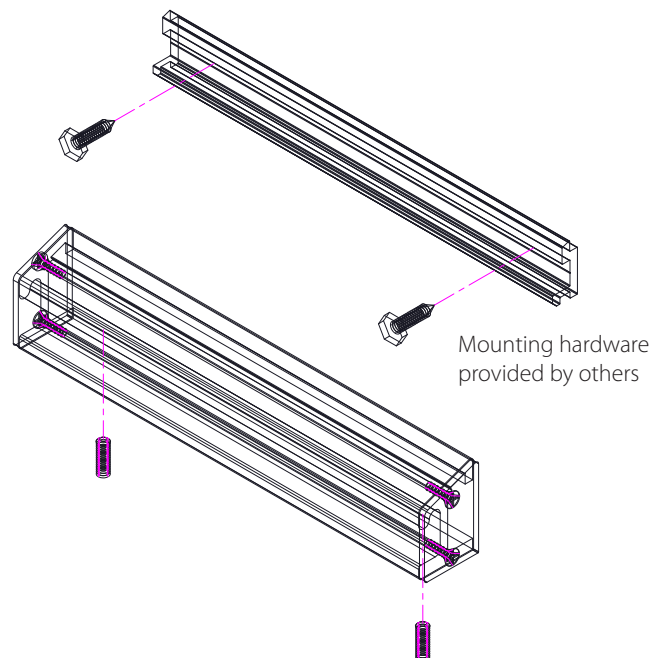

Section 3: Installation on Mounting Platform

ARS/VRS Mounting

ARS Mounting Systems can be used in conjunction with vertical rails, giving you the option for horizontal and vertical adjustments by easily sliding the ARS Rail in the tracks of the vertical rails.

NOTE: The ARS Rail now has the capability to move vertically and can be locked in your desired position by turning the black knob at the top of the BASK-VTRK-X adapter clockwise. Ensure that you tighten the knob to the tightest position to prevent the adapter from sliding down the channel.

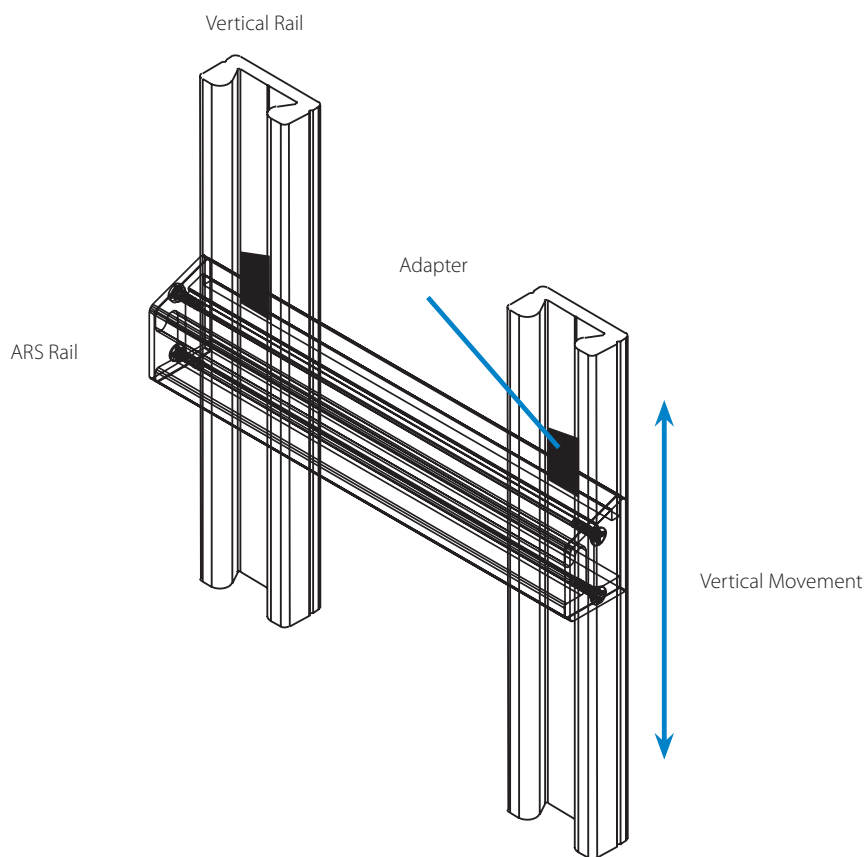

Section 4: Device Installation

Refer to specific device instruction manual.

Section 5: Maintenance, Troubleshooting and Product Classification

Troubleshooting

Symptom	Possible Cause	Solution
The rail is loose/unstable	The mounting screws have loosened	Contact structural engineer to discuss solution

Preventive Maintenance

⚠ WARNING: All products require periodic inspection and maintenance to perform optimally and achieve maximum operation life.

⚠ WARNING: The intervals shown below are recommended. Maintenance schedules should be more frequent for products that see heavy use.

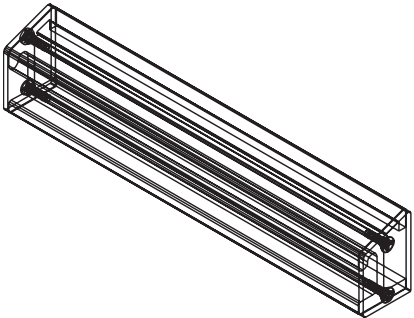
Area	Maintenance	Period (Months)
	<p>Entire ARS rail.</p> <p>A) Visually inspect for any loosening of any mounting screws on any ARS.</p> <p>B) Check rail screws every six months.</p>	6

Section 5: Maintenance, Troubleshooting and Product Classification

Cleaning

 **WARNING:** The cleaning chemicals and methods below are not meant for controlling any infections. It shall be the responsibility of the hospital or the hospital's infection control officer to sanitize the equipment.

 **WARNING:** Please do not spray any chemical directly onto the product. Apply onto a soft cloth and wipe clean to prevent chemicals getting into the internal components of the product.

The mounting assembly may be cleaned with most mild, non-abrasive solutions commonly used in the hospital environment (e.g. diluted bleach, ammonia, or alcohol solutions). The surface finish will be permanently damaged by strong chemicals and solvents such as acetone and trichloroethylene. Steel wool or other abrasive material should never be used. Damage caused by the use of unapproved substances or processes will not be warranted. It is recommended that you test any cleaning solution on a small area of the product that is not visible to verify compatibility. Never submerge the product and do not allow liquids to enter it. Wipe any cleaning agents off the product immediately using a water-dampened cloth. Dry the product thoroughly after cleaning.

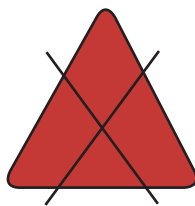

Acetone

(Figure 1)

No Acetone
Acetone is a colorless,
mobile, flammable liquid

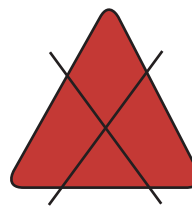

Trichloroethylene

(Figure 2)

No Trichloroethylene
Trichloroethylene is a chlorinated
hydrocarbon commonly used as
an industrial solvent.



Warranty Policy

Amico Accessories Inc. warrants all mounting accessories to be free from defects in material and workmanship for a period of twelve (12) months from the date of shipment. Within this period Amico Accessories Inc. will repair or replace any part which is proven to be defective.

Amico Accessories Inc. will warrant its materials to be free from defect for an additional period of four (4) years, five (5) years from the date of shipment. Within this period, Amico Accessories Inc. will replace any part at no charge, which is proven to be defective. Shipping and Installation costs after the first twelve (12) months will be borne by the customer.

This warranty is valid only when the product has been properly installed according to Amico Accessories Inc. specifications, used in a normal manner and serviced according to factory recommendations. It does not cover products that are not manufactured by Amico Accessories Inc. It does not cover failures due to damage which occurs in shipments or failures which resulted from accidents, misuse, abuse, neglect, mishandling, alteration, misapplication or damage that may be attributable to acts of God.

Amico Accessories Inc. shall not be liable for incidental or consequential damages resulting from use of equipment.

All claims for warranty must first be approved by Amico Accessories Inc. A valid Return Goods Authorization (RGA) number must be obtained from Amico Accessories Inc. prior to commencement of any service work. Warranty work, which has not been pre-authorized by Amico Accessories Inc., will not be reimbursed.

AMICO ACCESSORIES INC. DOES NOT HONOR VERBAL STATEMENTS CONCERNING THE WARRANTY.

The distributor and/or dealer are not sanctioned to create verbal warranties about the product described in this agreement. Any statements will not be honored or be made part of the agreement of sale. This document is the final complete and exclusive terms of the agreement.

THIS WARRANTY IS INCLUSIVE AND REPLACES ALL OTHER WARRANTIES.

Amico Accessories Inc. shall not, under any circumstances be liable for incidental or consequential damages including, but not limited to, profit, loss of sales or injuries to person(s) or property. Correction of noncompliance as noted above will result in completion of all liabilities of Amico Accessories Inc., whether based on agreement, neglect or changed materials, designs or specifications without notice.

All claims for warranty must first be approved by Amico Accessories Inc. Service Department: accessories@amico.com or 1.877.264.2697). A valid Return Goods Authorization number must be obtained from Amico Accessories Inc. prior to commencement of any warranty claim.

www.amico.com

Amico Accessories Inc. | www.amico.com

85 Fulton Way, Richmond Hill
Ontario, L4B 2N4, Canada

71 East Industry Court, Deer Park
NY 11729, U.S.A.

Toll Free Tel: 1.877.264.2697
Toll Free Fax: 1.866.440.4986
Tel:905.763.7778
Fax:905.763.8587
Email: info@amico.com