

Air and Vacuum Systems

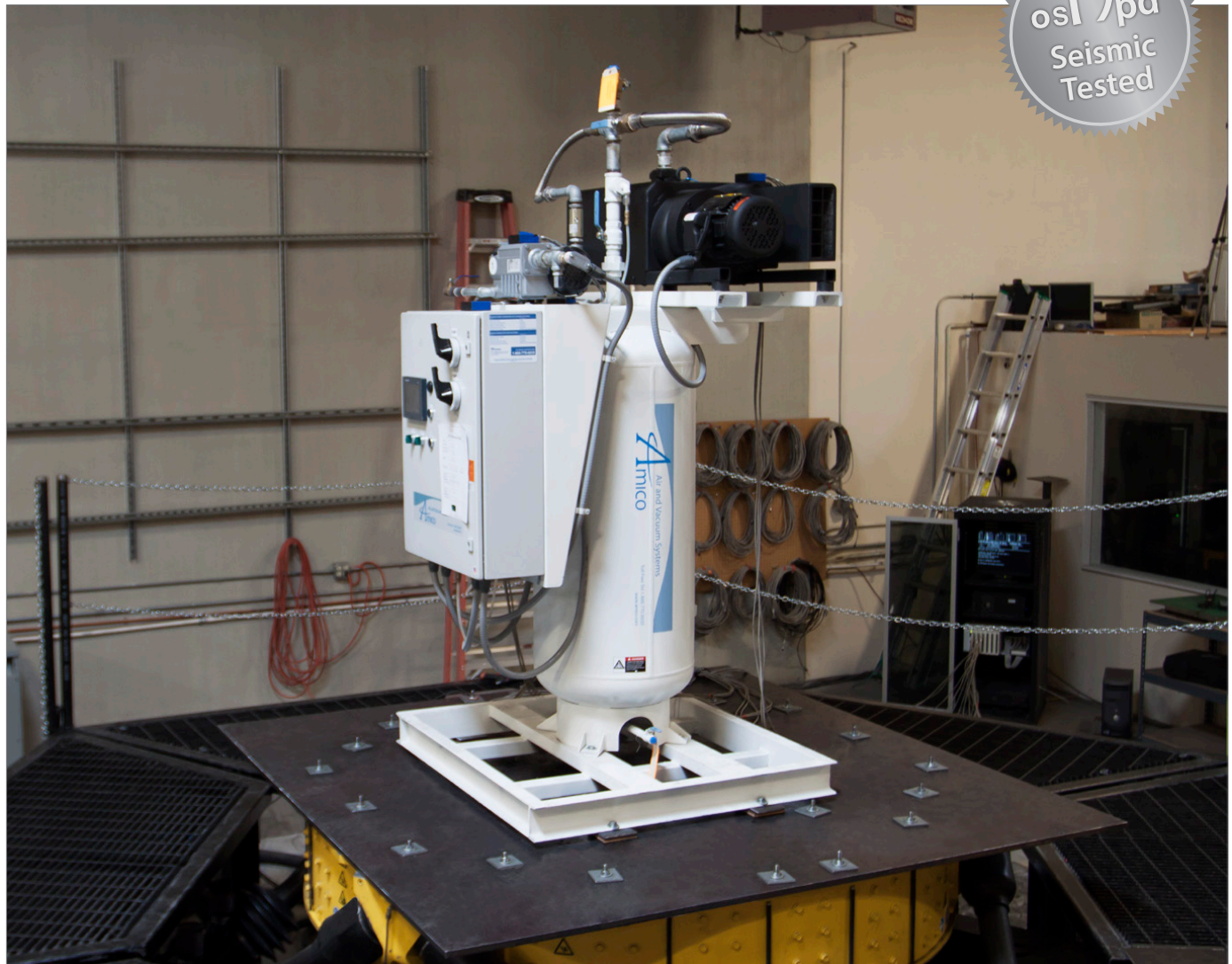

Seismic Testing

Amico Air Compressors and Vacuum Systems are now Seismic Approved!



We are pleased to announce that Amico Source now offers a full line of Medical Air Compressors and Vacuum Systems approved by OSHPD under the Special Seismic Certification Pre-approval Program OSP-0447-10. Achieving this Earthquake Resistant certification emphasizes the high caliber of engineering that goes into our Source Systems.

Amico Source Corporation is the first in the industry to offer Dry Vane Vacuum Systems and Reciprocating Medical Air Systems that are OSHPD approved under the OSP. We are also the first to offer Scroll Medical Air Systems at 20 hp that are OSHPD approved under the OSP — giving us the most comprehensive Seismic Approved product offering in the industry.

This milestone allows Amico Source Corporation to be the first to offer larger horsepower systems to the customer, providing more flow with less components. Our systems are Seismic Safe and easy to service.

To obtain Seismic approval, Amico Air Compressors and Vacuum Systems must be subjected to a physical, full system shaker table test. The system must also be in operation before and after the testing is complete. If the system were unable to produce air or vacuum without repair, after being shaken on the shaker table, it would fail the test. To further prove the quality of our products, we tested the largest possible unit with a configuration that is the most prone to failure.

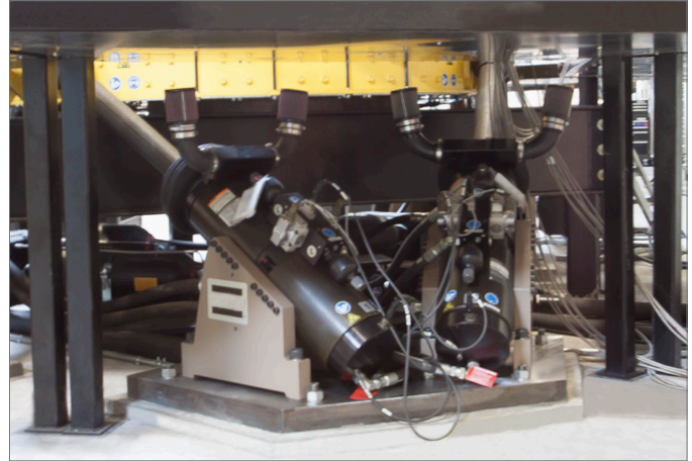

Shaker Table Hydraulics Control



Unit Under Test UUT14:
Triplex Stack Mounted Contact-less Claw Vacuum System

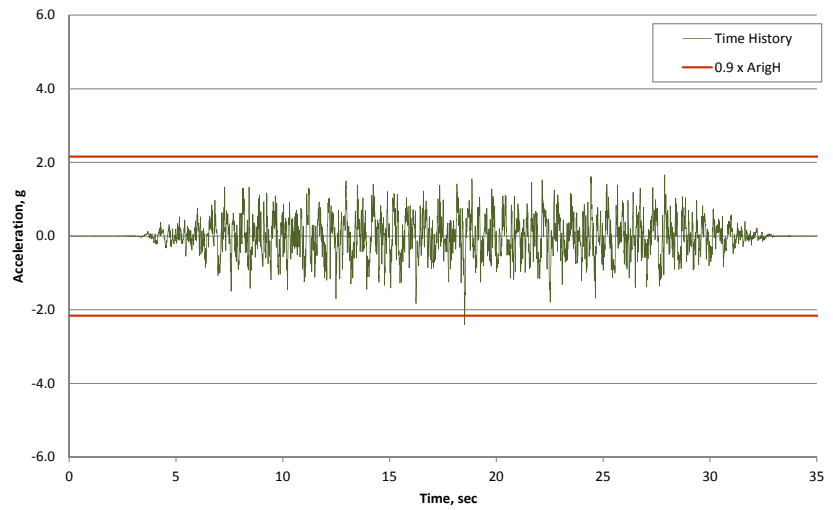

UUT14 Shaker Table Acceleration (X Axis, Horiz), Sds 2.5 g, z/h=1

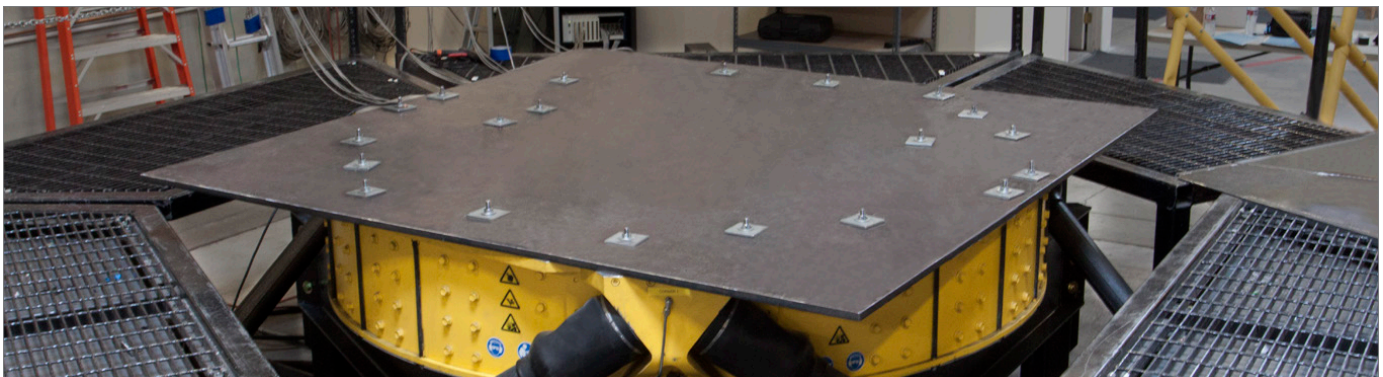

Shaker Table

Scroll Compressors

Medical Air Systems

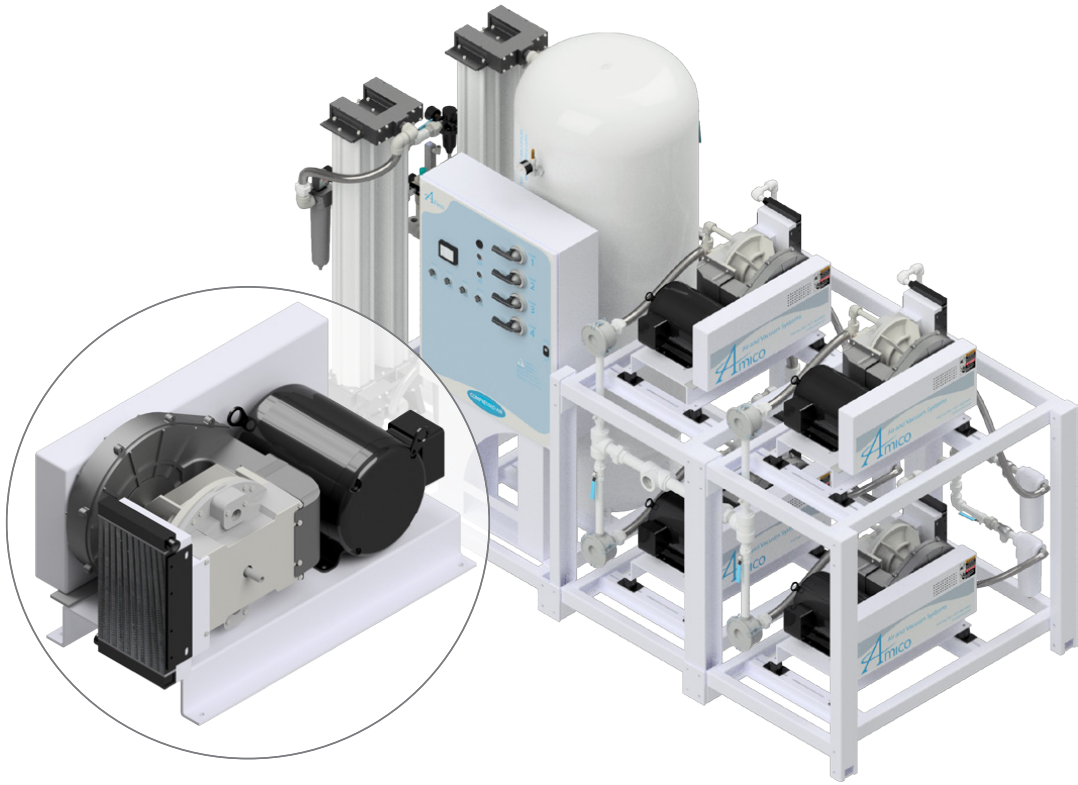

Operating without the application of oil during the compression process, Amico's scroll compressors will deliver the high quality, oil-less compressed air your facility demands. By utilizing Amico's scroll compressors, end users can rest assured that the system will run quietly with little vibration, low starting torque and low maintenance.

Our scroll compressor systems ensure pollutants and environmental contaminants are removed from the compressed air stream at all times, resulting in further savings for our customers on operating and maintenance costs.

Configurations

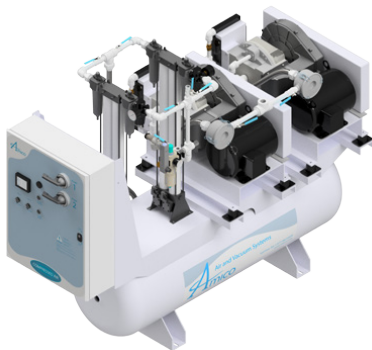

Duplex Horizontal Tank Mount



Low hp - Duplex Modular Stack Mount



High hp - Duplex Modular Stack Mount

Scroll Air Technology

Scroll compressors are orbital motion, positive displacement compressors whereby suction and compression are obtained through the utilization of two mating, spiral shaped scroll halves (one fixed and one orbiting).

The fixed scroll is attached to the compressor body and the orbiting scroll is coupled to the crankshaft and rotates rather than being stationary. The orbiting motion creates a series of gas pockets traveling between the two scrolls. On the outer portion of the scroll, the pockets draw in gas and move to the center of the scroll where the gas will be discharged.

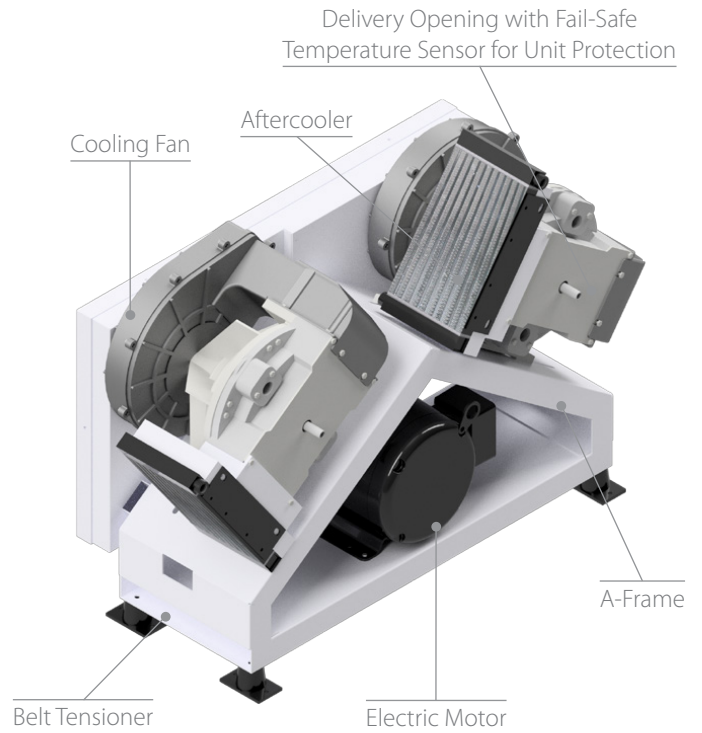

Low hp - Triplex Modular Stack Mount

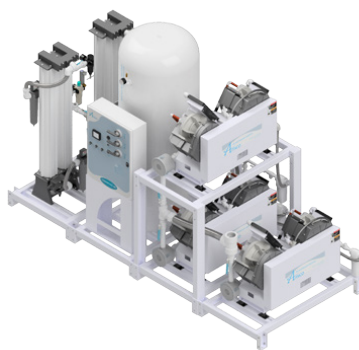

High hp - Triplex Modular Stack Mount



Quadruplex Modular Stack Mount

Reciprocating Compressors

Medical Air Systems

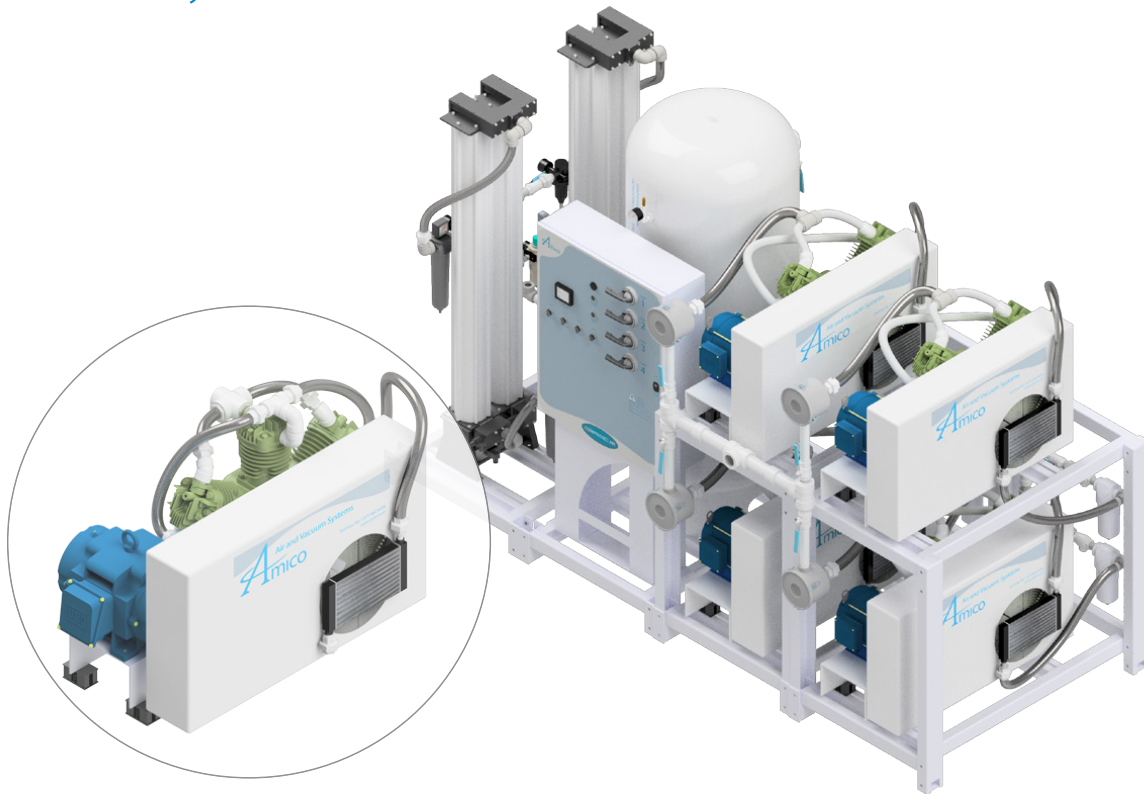

With decades of accumulated experience, our proficiency in evaluating and applying air compressors, filters, regulators, dryers and dew point/CO instrumentation has enabled us to develop and manufacture the newest class of reciprocating air compressors.

What differentiates Amico's reciprocating air compressors from the rest is that we have a renowned reputation for manufacturing the most reliable and efficient compressors. Our mandate at Amico is to reduce unnecessary expense for our clients while ensuring each assembly is vigilantly designed for reliability and air purity.

Configurations



Horizontal Tank Mount



Low hp - Duplex Modular Stack Mount



High hp - Duplex Modular Stack Mount

Reciprocating Air Technology

The reciprocating air compressor system is the most widely used equipment for gas service. The basic design consists of a piston in a cylinder with pressure-actuated check valves to control suction and discharge flow through the cylinder.

Standard practice is to have the piston driven by a rod passing through a packing case to seal against pressure leaks. With this design, gas can be compressed on both sides of the piston.

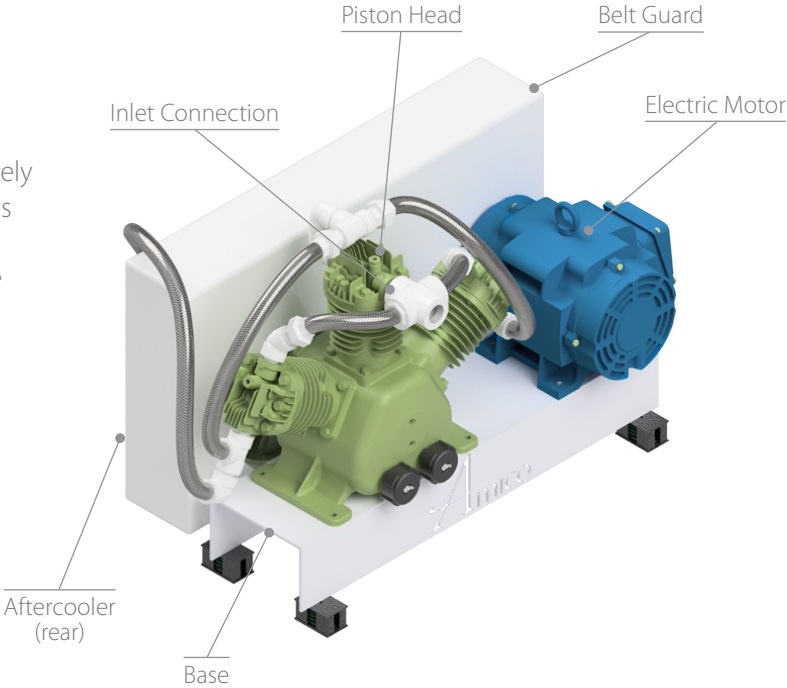

Low hp - Triplex Modular Stack Mount



High hp - Triplex Modular Stack Mount



Quadruplex Modular Stack Mount

Contact-Less Claw Vacuum Systems

Medical Vacuum Systems

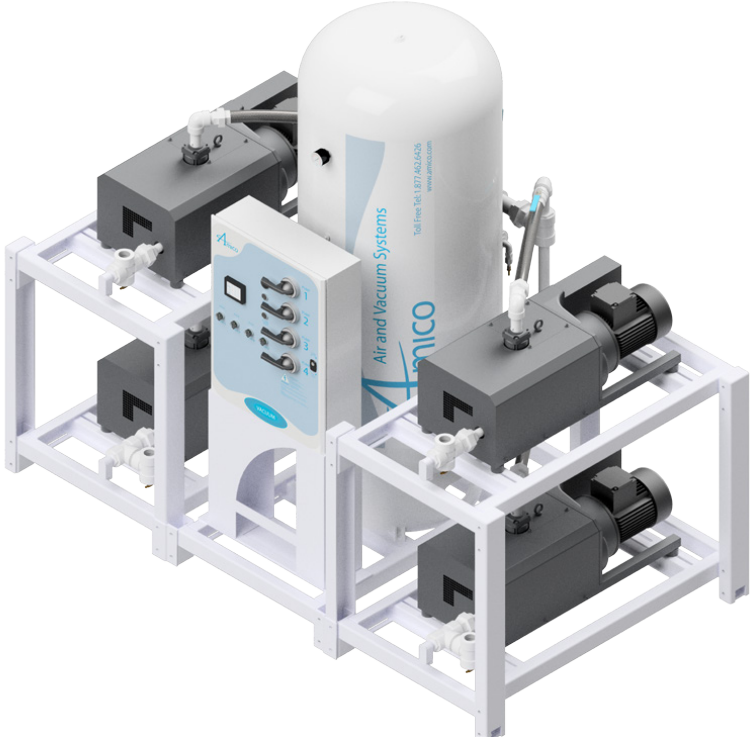

Amico's contact-less claw vacuum systems are refined and economical in design. Utilizing the most advanced technology of an oil-less, high efficiency, frictionless claw mechanism, end users are provided with the most energy saving and high performance system possible.

Operating friction-free with no lubrication necessary for proper functioning, selecting Amico guarantees cost effectiveness. Capable of producing the most CFM per HP of any medical vacuum technology, our contact-less claw is capable of running reliably for a lengthy duration without the necessity of frequent maintenance.

Configurations

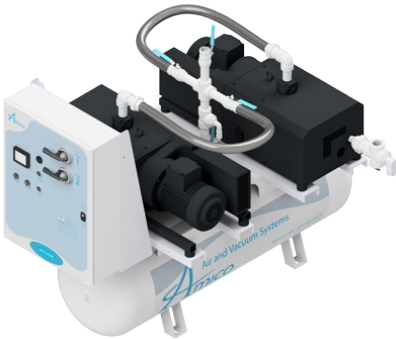

Duplex Horizontal Tank Mount



Duplex Vertical Tank Mount



Duplex Modular Stack Mount

Claw System Technology

Located within the compression chambers are two claw shaped rotors which trap air as they rotate in opposite directions without the use of friction or lubrication. Subsequently, the air is compressed by the rotor and released through a silencer into the atmosphere.

The non-return valve incorporated into the inlet flange prevents air from flowing back into the vacuum chamber when the pump is shut off.

The contact-less claw vacuum pumps are direct driven by a flanged motor and coupling is synchronized via precision gears.

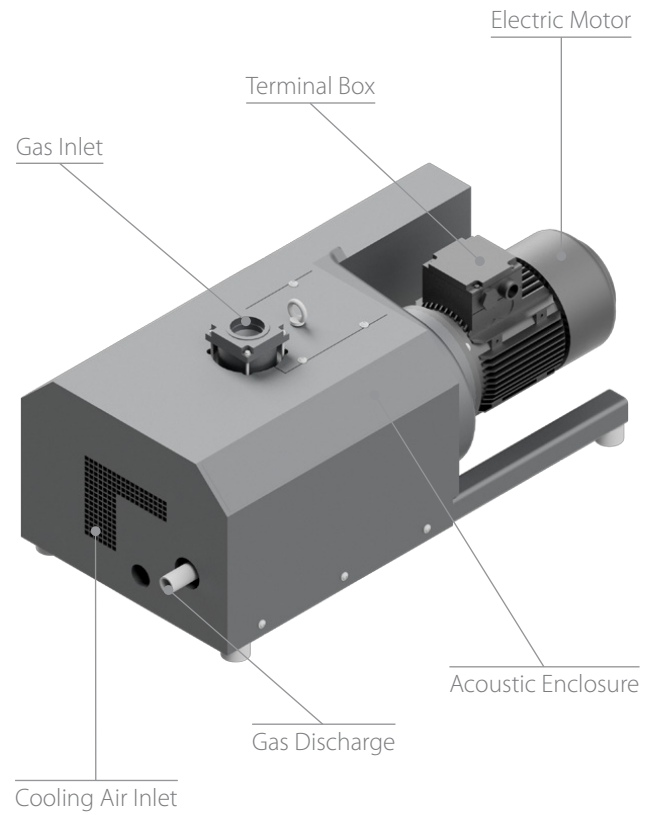

Triplex Modular Stack Mount

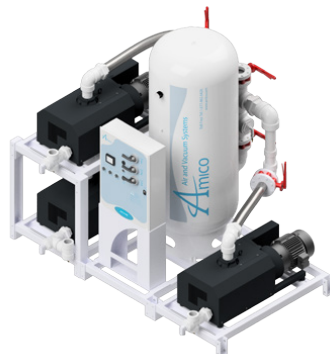

Triplex Modular Stack Mount

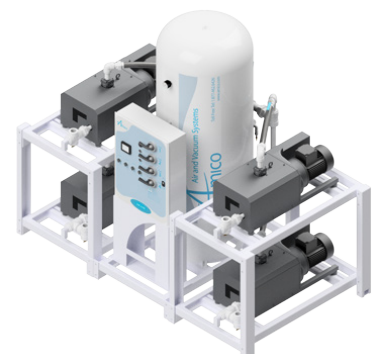

Quadruplex Modular Stack Mount

Lubricated Rotary Vane Vacuum Systems

Medical Vacuum Systems

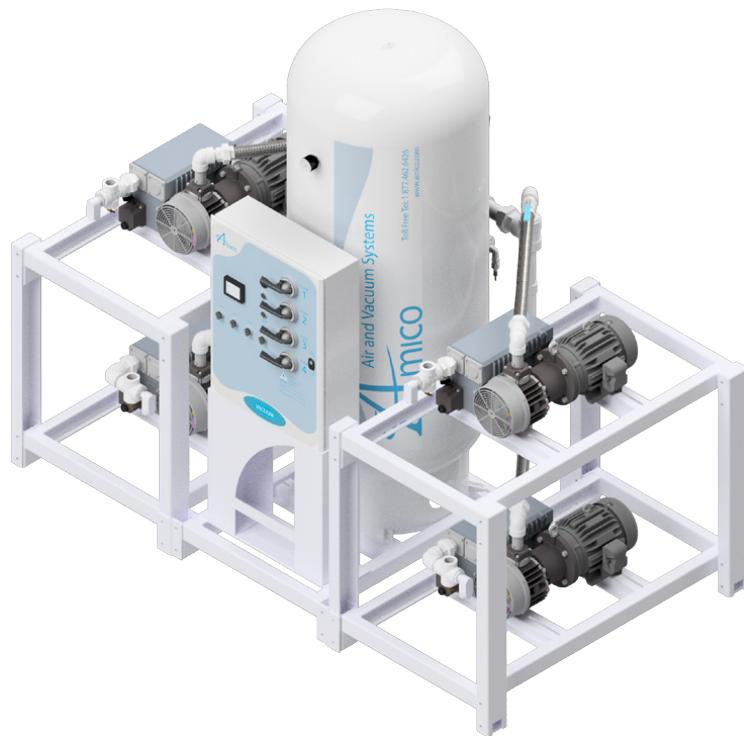

The Amico lubricated rotary vane vacuum pumps are single-staged, air-cooled and direct driven. Proven to be one of the most reliable pumps currently available in the industry; the compact, simple design offers low maintenance as well as quiet and long lasting operation to end users.

Constructed with direct driven vacuum pumps, this assembly eliminates potential wearing or loosening of gears. Additionally, the dynamically balanced multi-vane design yields maximum heat dissipation for the vacuum system.

Configurations

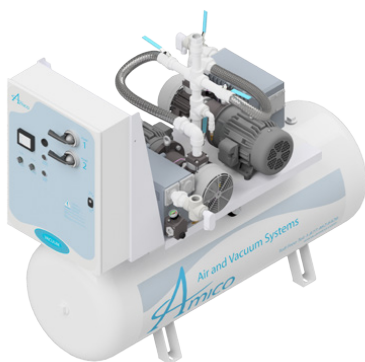

Duplex Horizontal Tank Mount



Duplex Vertical Tank Mount



Duplex Modular Stack Mount

Lubricated Rotary Vane System Technology

The lubricated rotary vane consists of a rotor positioned within the cylindrical housing such that it operates in close proximity to the cylinder. When the rotor begins to rotate, centrifugal force pushes the blades out of the rotor slots, causing them to slide against the internal surface of the cylinder.

During rotation, a volume of air is created. Subsequently, air enters into a cell through the inlet port upon achieving its maximum air volume. As a result of the cell moving away from the inlet port, its volume becomes smaller and the air becomes compressed.

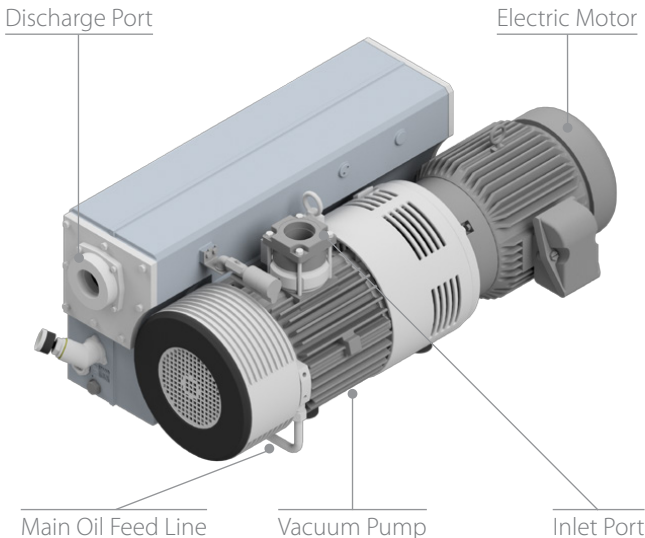

Triplex Modular Stack Mount

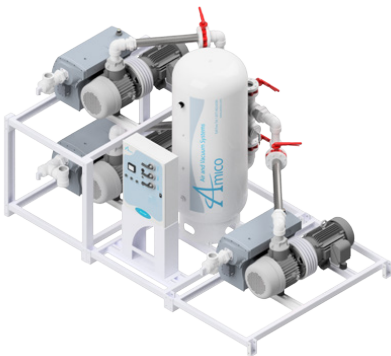

Triplex Modular Stack Mount

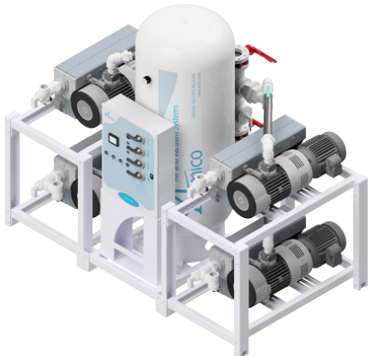

Quadruplex Modular Stack Mount

Dry Rotary Vane Vacuum Systems

Medical Vacuum Systems

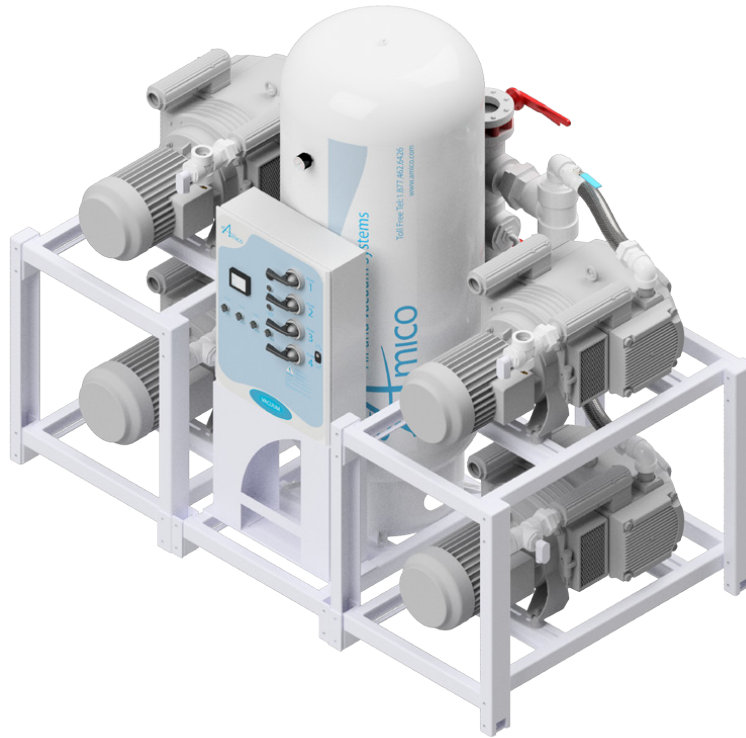

The oil-less rotary vane vacuum pumps are designed to meet the demanding requirements of various medical facilities. Thanks to the implementation of a very simple yet highly reliable design, Amico's oil-less rotary vane pumps provide excellent vacuum performance.

Constructed with self-lubricating, carbon/graphite vanes and operating 100% oil-free, we guarantee our clients the following benefits: no oil leakages, less frequent vane change out and low operation and maintenance cost.

Configurations



Duplex Horizontal Tank Mount

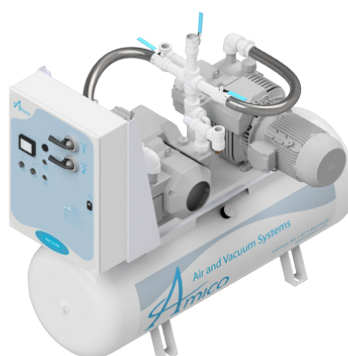

Duplex Horizontal Tank Mount



Duplex Vertical Tank Mount

Dry Rotary Vane System Technology

The dry rotary vane vacuum pump motor, located within the pump cylinder, traps entering vapor between rotor vane segments. As the rotor rotates, centrifugal force causes the vanes to slide outward generating a seal against the cylinder wall.

The vanes are constructed of a self-lubricating graphite material allowing them to operate against the cylinder wall without the need for lubricating fluid.

Due to the offset rotor, variable volumes are formed in the cylinder housing creating a flow of vapor through the pump. Vapor is then pulled into the pump inlet which will be compressed and discharged through the exhaust into the atmosphere.

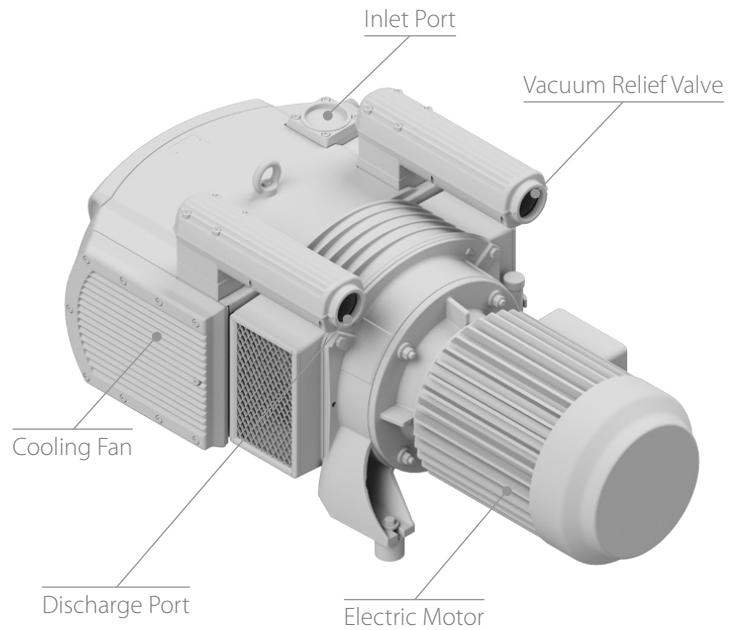

Triplex Modular Stack Mount

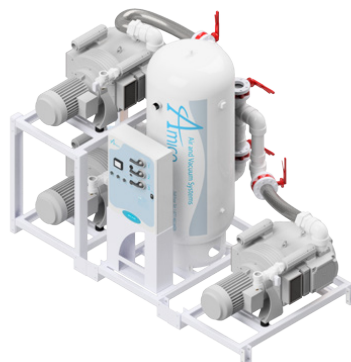

Triplex Modular Stack Mount

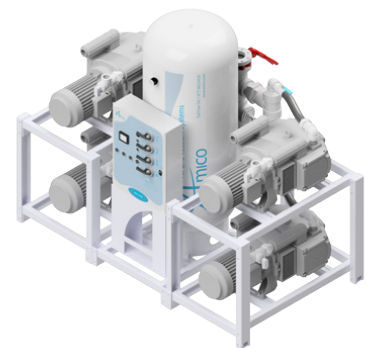

Quadruplex Modular Stack Mount

Touchscreen Control Panel

All of Amico's medical air compressors and vacuum systems feature a high-resolution Human Machine Interface (HMI) Touchscreen Control Panel. Constructed with multiple screens, pop-ups and alarms, the compact size and slim contour of the Touchscreen Control Panel allows it to be easily integrated.

This Touchscreen Control Panel enhances communication between the user and the system by functioning as the medium over which various networks, PLC and databases communicate.

The HMI embedded network gathers all vital information from your alarms and Source Equipment and places them at your fingertips. Ethernet connectivity with an embedded web server provides access to pertinent information, statistics and trends from your desktop or any computer in the facility.

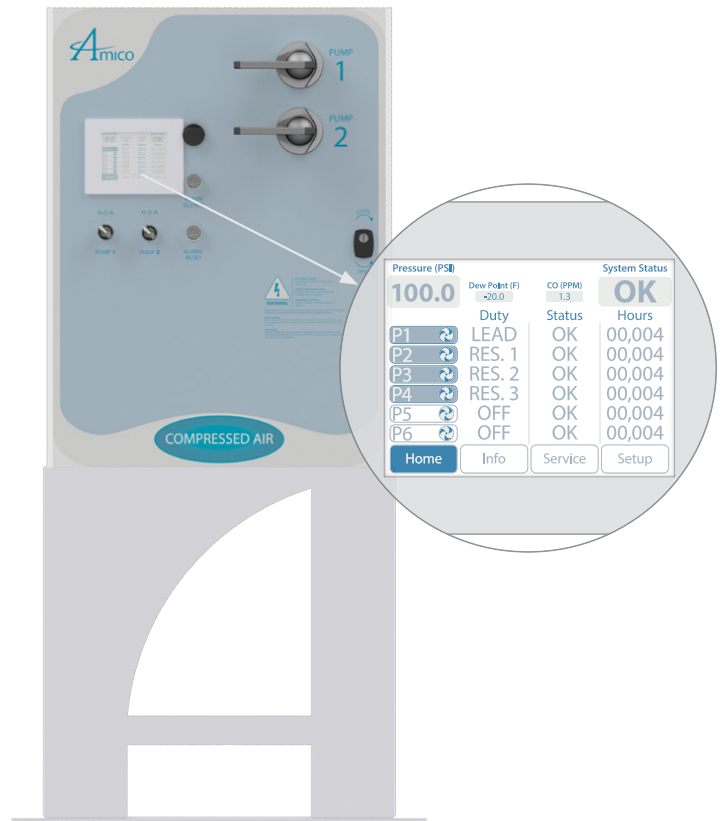

Screen Indicators

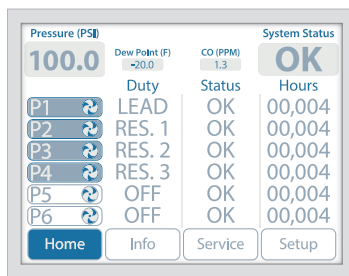

Home Screen

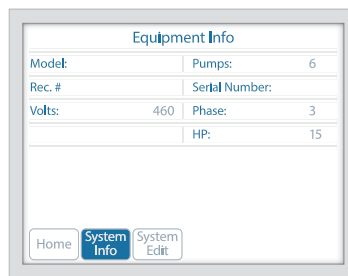

Info Screen

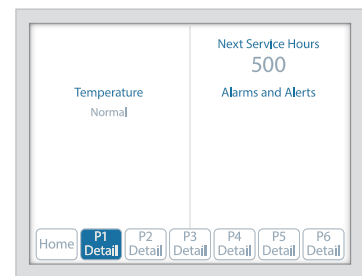

Service Screen

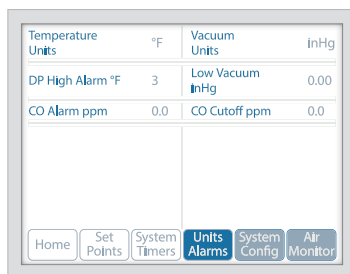

Alarms Set Up

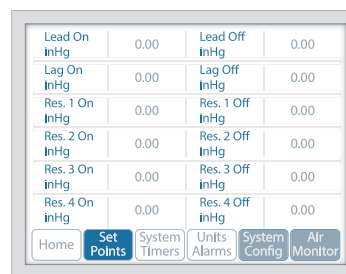

Set Points Set Up

Dryer/Filter/Regulator System

Medical Air Dryer Systems

Amico's medical air dryer ensures the delivery of clean, dry medical air at all times, irrespective of environments. With the implementation of an air-cooled aftercooler, Amico's air dryer is certain to provide effective dryer operation and guarantee dew point performance.

In addition, the coalescing filters within the dryer remove liquids and particles from the air stream, enhancing and protecting the delivery of medical air.

This medical air dryer is compatible with all of our scroll compressors and reciprocating compressors.

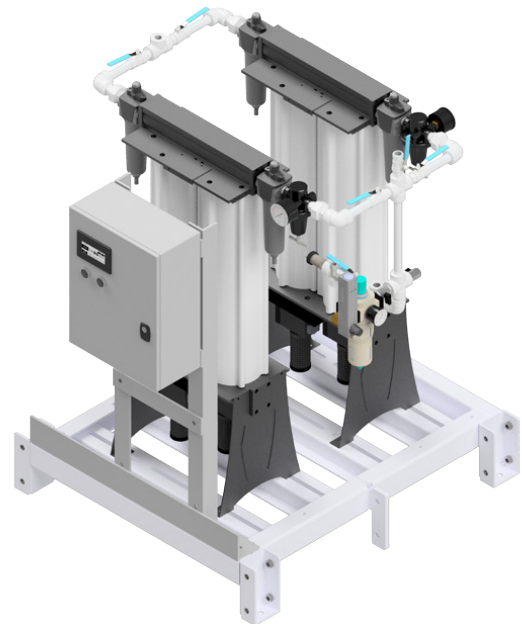

Air Receiver Tank

The air receiver is utilized as a storage medium and control system to ensure a steady flow of air. The air receiver tank also eliminates pulsation from the discharge line, reduces energy costs associated with excessive starting of the motor and assists in separating moisture, oil and particulates from the air.

Amico's air receivers are ASME certified and are rated for low and high design pressures up to 300 psi. The inside of the receiver consists of a two-part epoxy coating which provides rust protection equal to or better than that achieved by galvanizing.

Our standard air receiver tanks can be mounted horizontally or vertically. Customized configurations are also available to suit your facility's needs.

Amico Source Medical Air Systems

Reciprocating and Scroll – up to 20 hp

Advantages:

- Customizable configurations
- Ability to produce high capacity with one compressor
- Compact and lightweight
- Reliable
- Low noise level
- Vibration free

Oil-less Reciprocating Air Compressor



Triplex 20 hp Reciprocating Air Compressor System

Oil-less Scroll Air Compressor



Duplex 20 hp A-Frame Scroll Air Compressor System

Our Wide Variety of Reciprocating and Scroll Compressors are Suitable for Many Applications

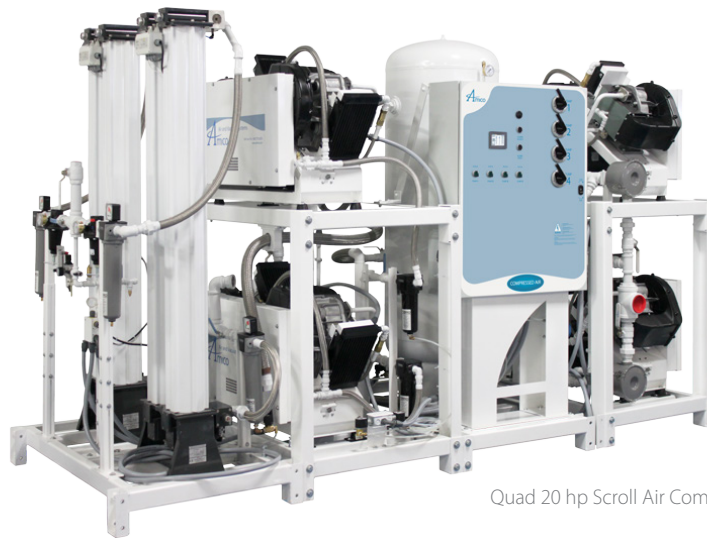

Quad 20 hp Scroll Air Compressor System

Reciprocating Air Compressor Systems



Simplex 1 hp



Duplex 5 hp



Duplex 15 hp

Scroll Air Compressor Systems



Duplex 2 hp



Triplex 5 hp



Duplex 10 hp

Amico Source Medical Vacuum Systems

Contact-less Claw, Dry Rotary Vane and Lubricated Rotary Vane

Advantages:

Contact-less Claw

- Low operating cost
- Excellent choice for dedicated anesthesia evacuation system

Dry Rotary Vane

- Low maintenance
- Low run temperature
- No sealing fluid

Lubricated Rotary Vane

- High vacuum
- No rust and scale problems
- Low noise level

Lubricated Rotary Vane Pump



Duplex 10 hp Lubricated Rotary Vane Vacuum System

Configuration Examples



Duplex 10 hp Dry Rotary Vane



Duplex 20 hp Lubricated Rotary Vane



Triplex 5 hp Contact-less Claw

Rescue of 33 Trapped Chilean Miners

Atacama Desert, Chile (October 2010)

When disaster struck...



...Amico was there

When disaster struck on August 5th, 2010; the world was watching as the news unfolded of the San José copper and gold mine collapse. Over 33 Chilean miners were trapped below the surface, with more than 2,000 feet of rock between themselves and their families.

Members of a rescue team worked tirelessly for 69 days to save the crew. Beneath the rubble, the miners began their efforts to survive, but it was clear they were running out of air.

Above the rubble, Amico's equipment was used in the enormous undertaking of saving these miners. We were the only company in the industry that could provide a complete and fully functional system in such a short lead time. Our medical air system was the sole system which the 33 miners depended on for breathing while they were trapped in these dire conditions.

The miners were saved; and Amico was there. Our turnaround time continues to this day to be industry leading, no matter what the situation. We did it for them, and we can do it for you too.



Amico Source Corporation | 85 Fulton Way, Richmond Hill, ON L4B 2N4, Canada
71 East Industry Court Deer Park, NY 11729, USA
Toll Free Tel: 1.877.462.6426 | Toll Free Fax: 1.866.440.4986
Tel: 905.764.0800 | Fax: 905.764.0862
Email: info@amico.com | www.amico.com

Represented By: