

# DUPLEX RECIPROCATING AIR PLANT WITH DESICCANT AIR TREATMENT SYSTEM (1.0 HP - 5.0 HP)

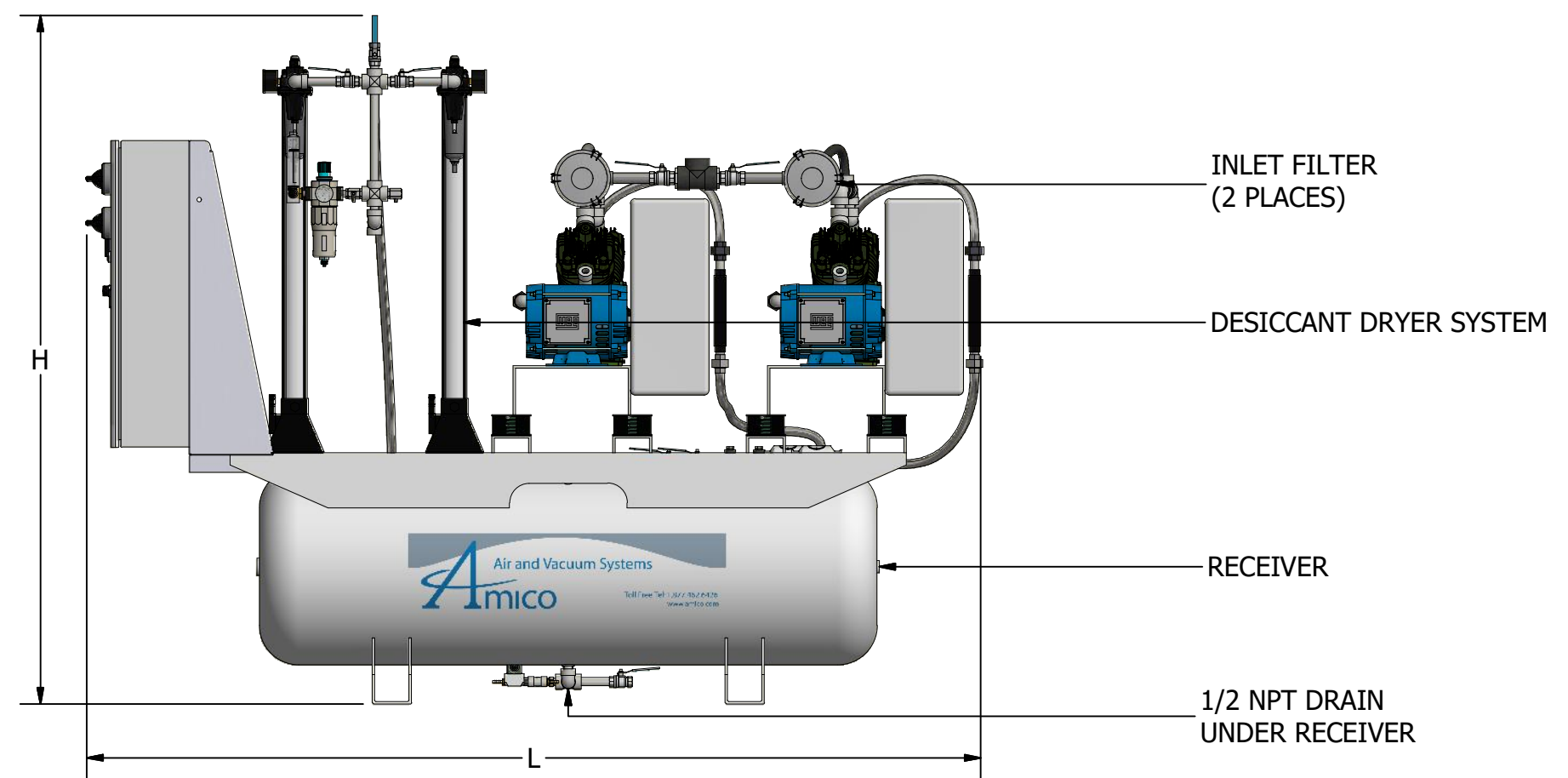
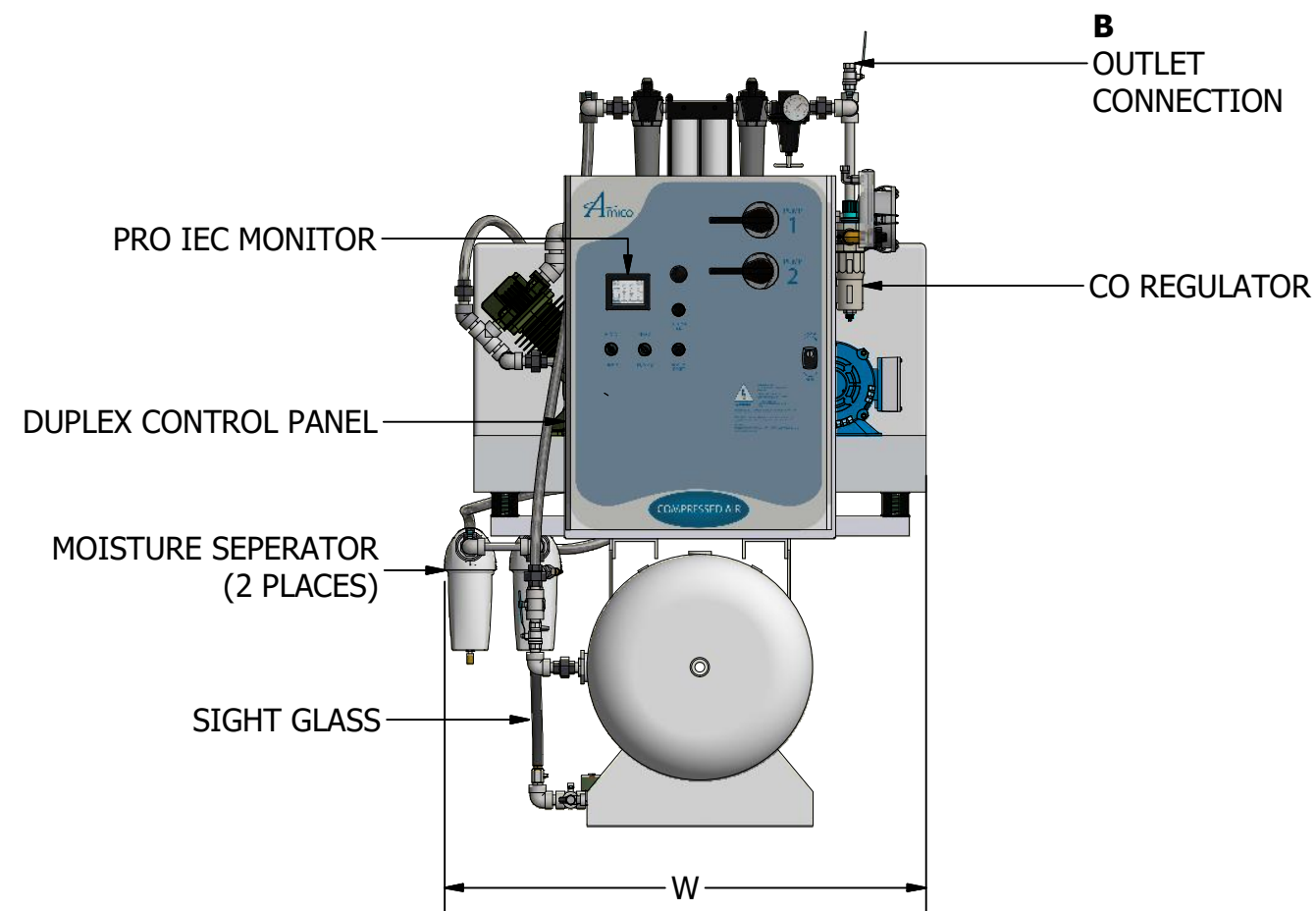
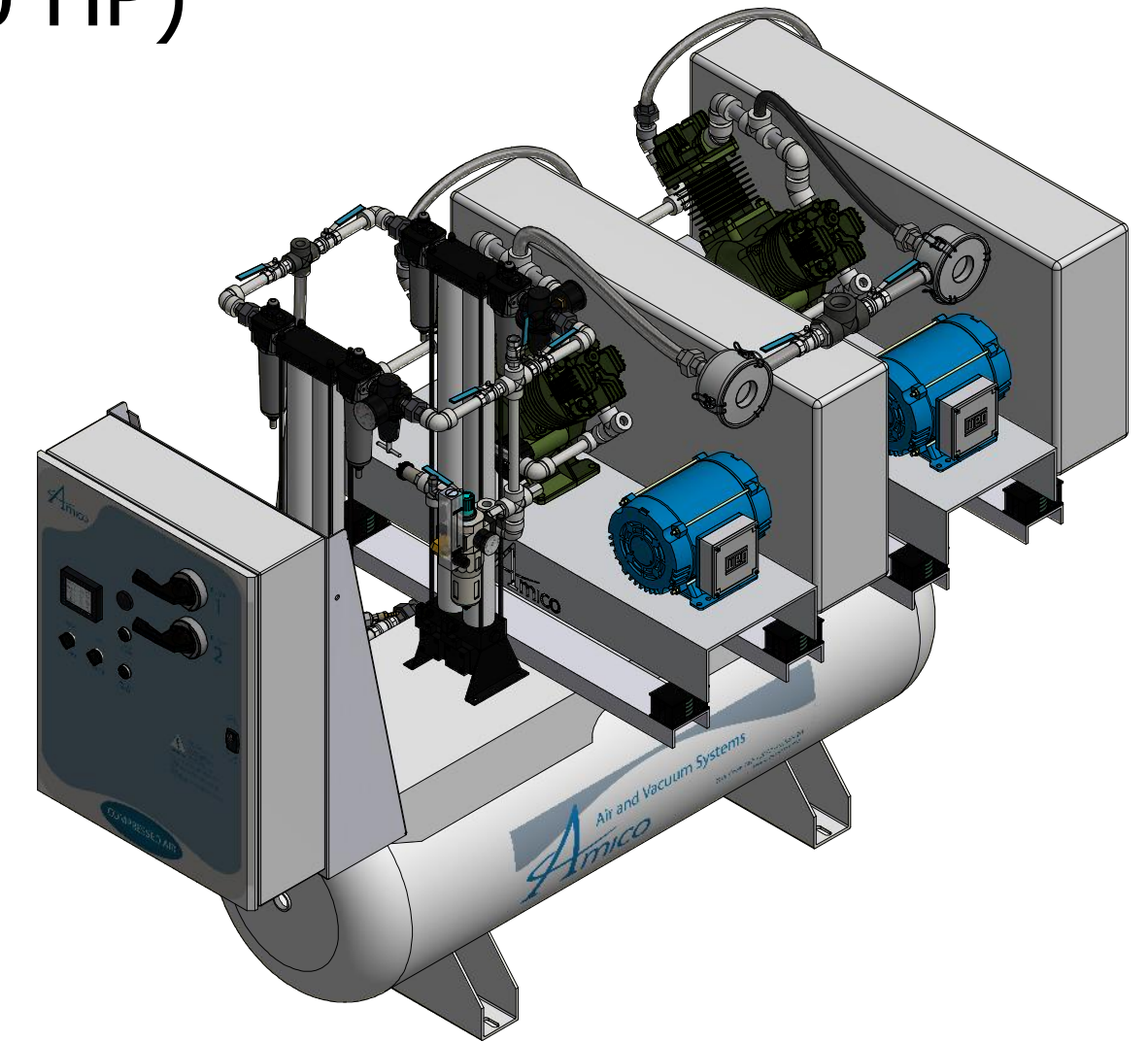
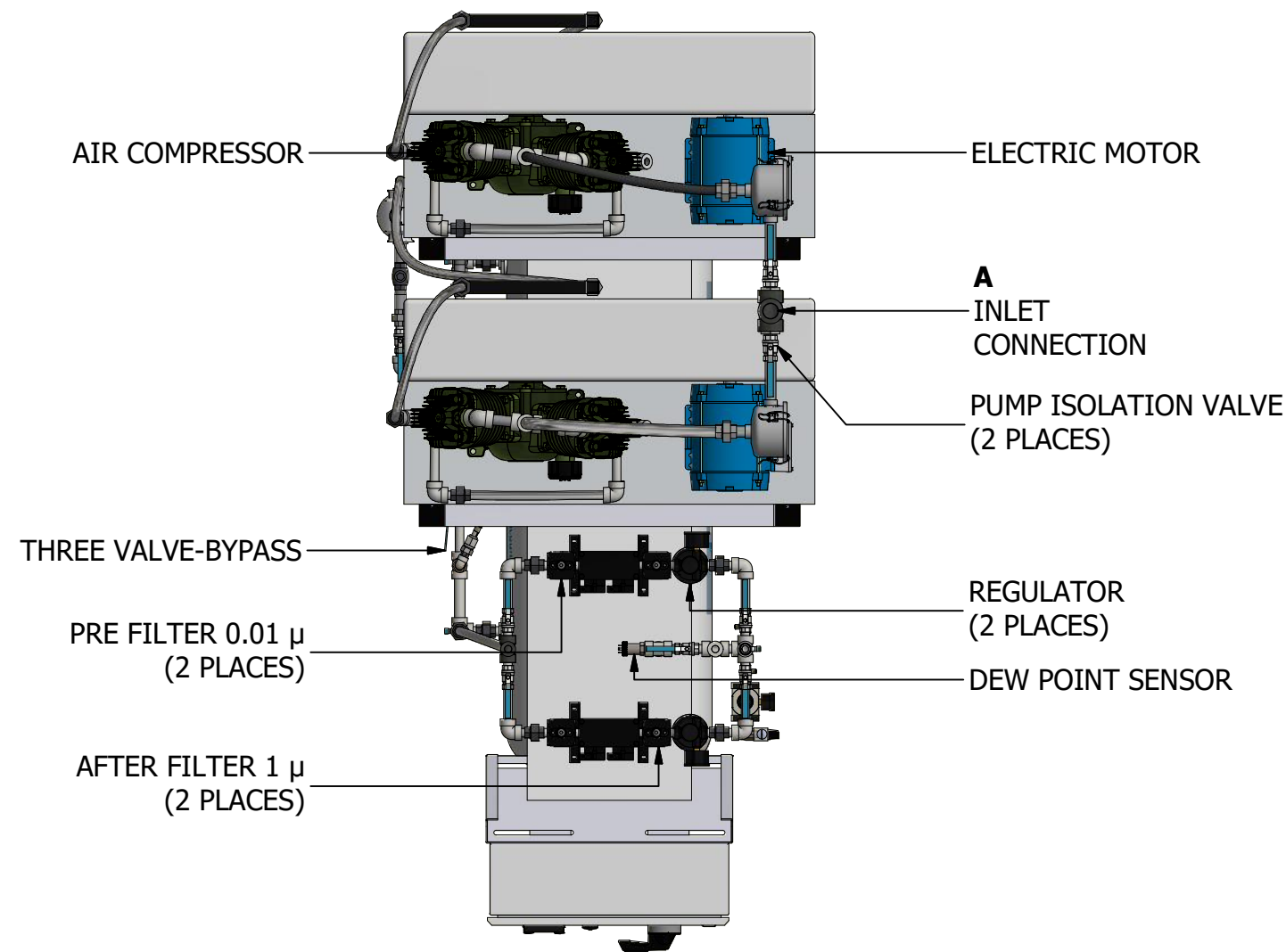

DIMENSIONS SUBJECT TO CHANGE WITHOUT NOTICE

\*SYSTEM CONFIGURATION DIFFERS FROM MODEL SHOWN

\*\*380 VOLT DATA PROVIDED AT 50HZ  
ALL OTHER VOTAGES ARE RATED AT 60HZ

ADDITIONAL MODELS AVAILABLE UPON REQUEST

MODEL	HP (KW)	A INLET NPT	B OUTLET NPT	TANK SIZE GALLON (LITRE)	COMPRESSOR SCFM (LPM)		NFPA SYSTEM CAPACITIES WITH ONE COMPRESSOR ON STANDBY (LPM)		WEIGHT IN LBS (KG)	SQ. FT. REQUIRED (M <sup>2</sup> )	SYSTEM FLA (WITH ALL COMPRESSORS RUNNING)				SYSTEM BTU/HR	SOUND LEVEL dB (A)	W (M)	L (M)	H (M)
					@ 50 psig	@ 100 psig	@ 50 psig	@ 100 psig			208V	230V	380V**	460V					
A-RED-D-080P-TH-N-010*	1 (0.75)	1.25	0.5	80 (303)	4.1 (116)	3.3 (93)	4.1 (116)	3.3 (93)	1153 (523)	28.1 (2.61)	15	16	8	8	2,544	72	45 (1.14)	90 (2.29)	74 (1.88)
A-RED-D-120P-TH-N-010*	1 (0.75)	1.25	0.5	120 (454)	4.1 (116)	3.3 (93)	4.1 (116)	3.3 (93)	1253 (568)	30.0 (2.79)	15	16	8	8	2,544	72	45 (1.14)	96 (2.44)	77 (1.96)
A-RED-D-080P-TH-N-020	2 (1.49)	1.25	0.5	80 (303)	7.8 (221)	6.6 (187)	7.8 (221)	6.6 (187)	1213 (550)	28.1 (2.61)	21	19	11	10	5,089	73	45 (1.14)	90 (2.29)	74 (1.88)
A-RED-D-120P-TH-N-020*	2 (1.49)	1.25	0.5	120 (454)	7.8 (221)	6.6 (187)	7.8 (221)	6.6 (187)	1313 (596)	30.0 (2.79)	21	19	11	10	5,089	73	45 (1.14)	96 (2.44)	77 (1.96)
A-RED-D-080P-TH-N-030*	3 (2.24)	1.25	0.5	80 (303)	10.1 (286)	9.4 (266)	10.1 (286)	9.4 (266)	1297 (588)	28.1 (2.61)	27	25	13	12	7,633	74	45 (1.14)	90 (2.29)	73 (1.85)
A-RED-D-120P-TH-N-030*	3 (2.24)	1.25	0.5	120 (454)	10.1 (286)	9.4 (266)	10.1 (286)	9.4 (266)	1397 (634)	30.0 (2.79)	27	25	13	12	7,633	74	45 (1.14)	96 (2.44)	77 (1.96)
A-RED-D-080P-TH-N-050*	5 (3.73)	1.25	0.5	80 (303)	18.4 (521)	15.4 (436)	18.4 (521)	15.4 (436)	1400 (635)	28.1 (2.61)	41	36	19	18	12,722	76	45 (1.14)	90 (2.29)	73 (1.85)
A-RED-D-120P-TH-N-050*	5 (3.73)	1.25	0.5	120 (454)	18.4 (521)	15.4 (436)	18.4 (521)	15.4 (436)	1500 (680)	30 (2.79)	41	36	19	18	12,722	76	45 (1.14)	96 (2.24)	78 (1.98)



85 Fulton Way, Richmond Hill  
Ontario, L4B 2N4 Canada  
71 East Industry Court  
Deer Park, NY 11729  
Direct Tel: 905.764.0800  
Tel: 1.877.462.6426  
Fax: 1.866.440.4986



# DUPLEX RECIPROCATING AIR PLANT WITH DESICCANT AIR TREATMENT SYSTEM (1.0 HP - 20.0 HP)

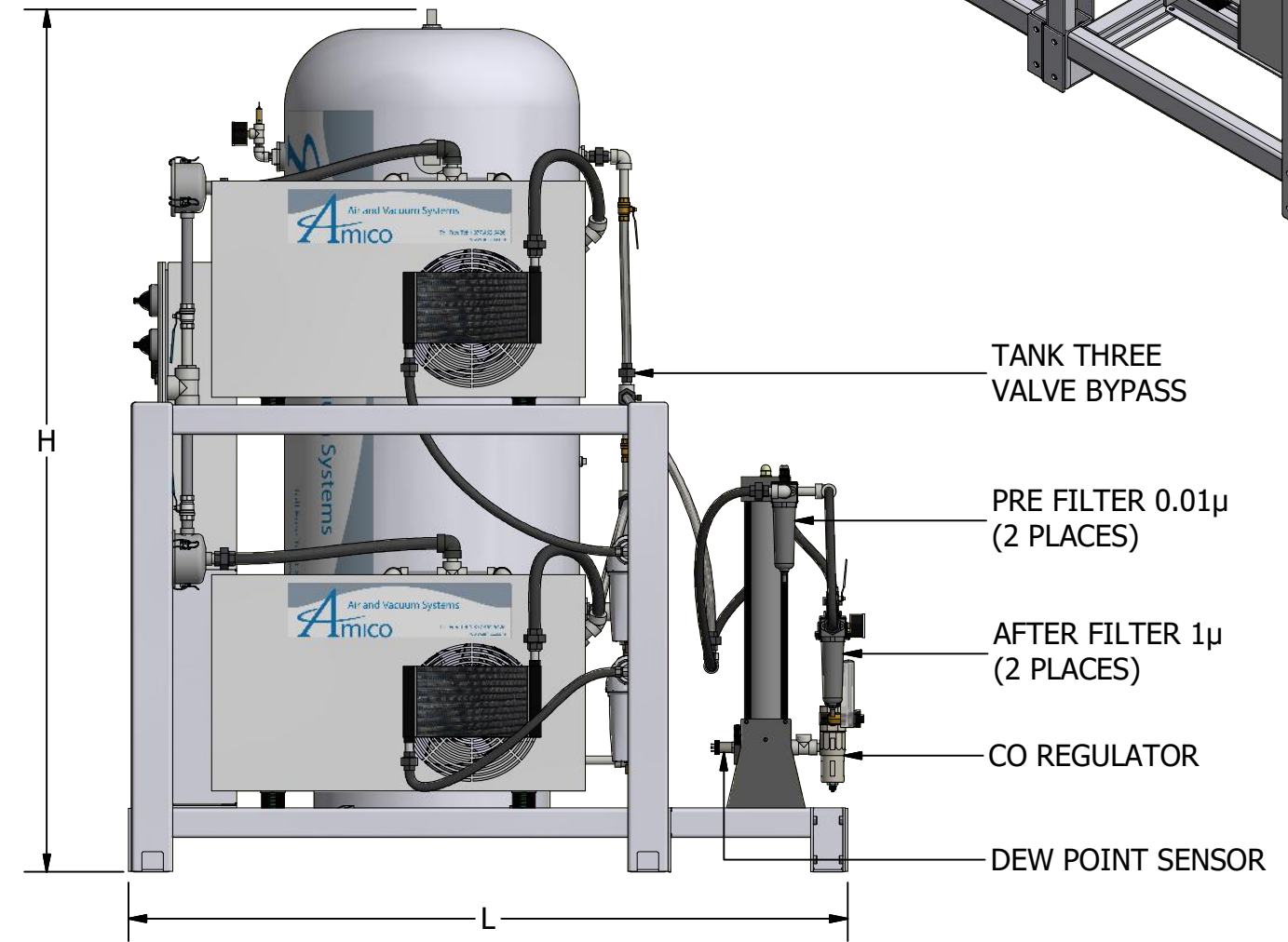
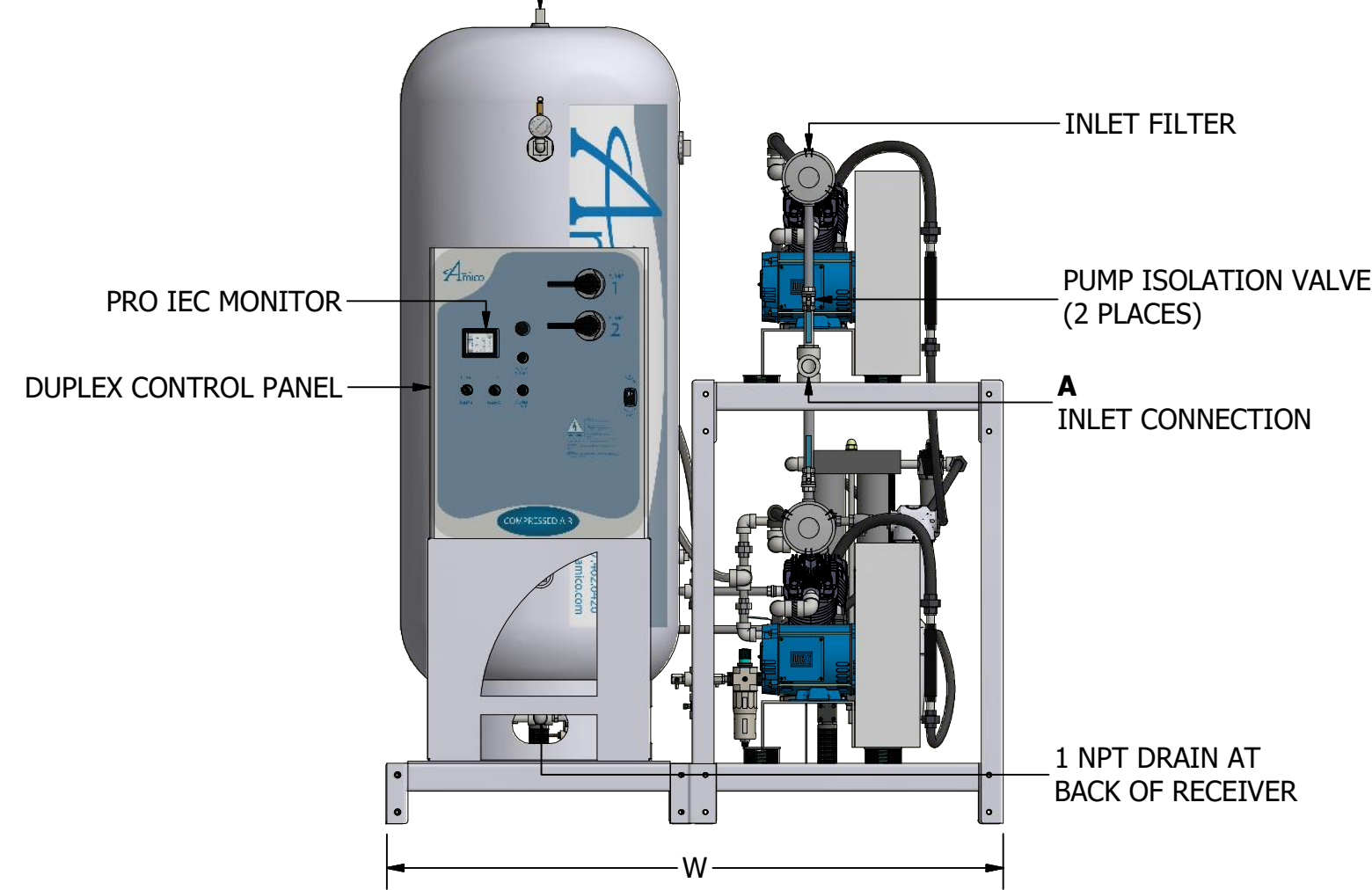
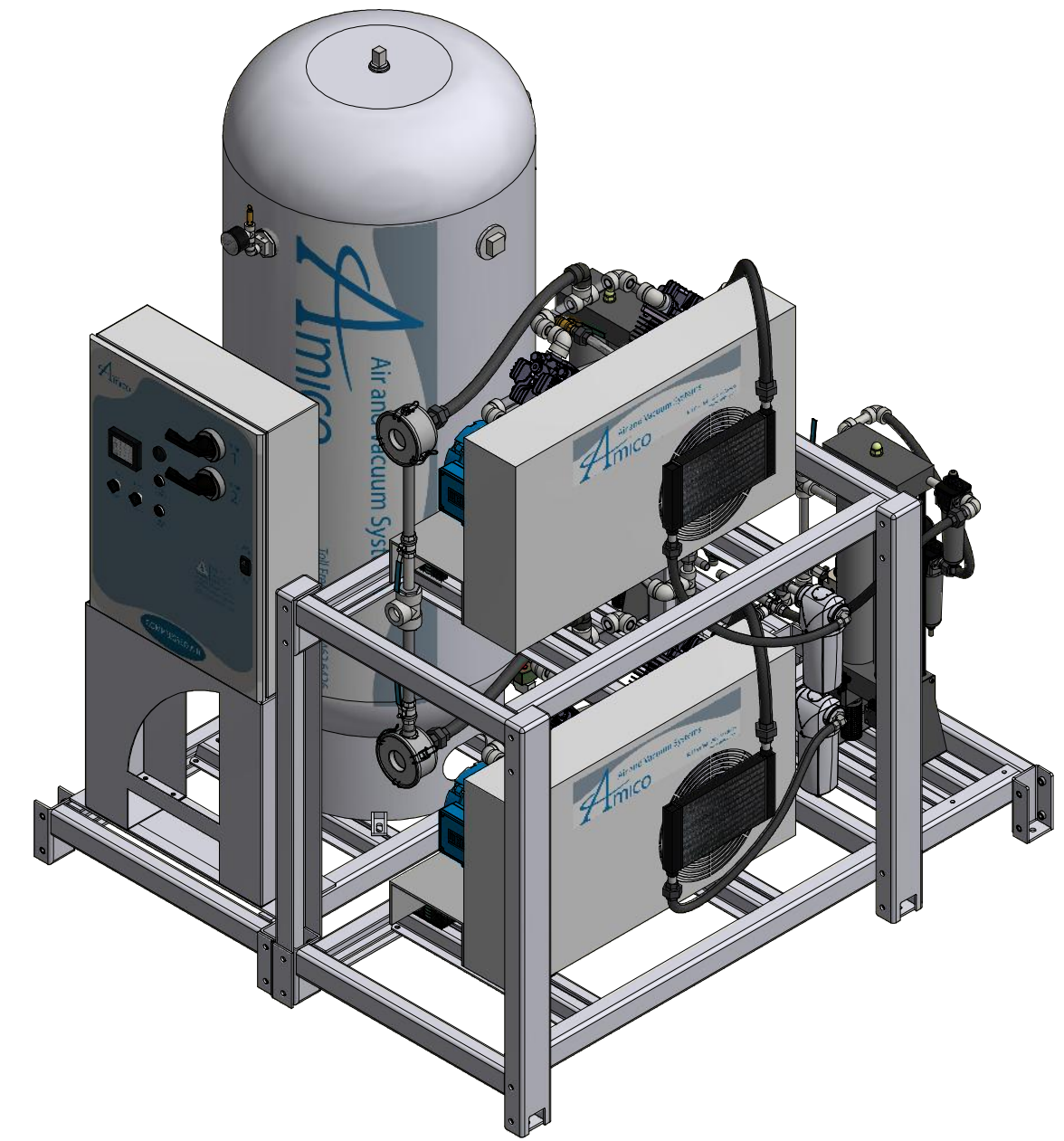
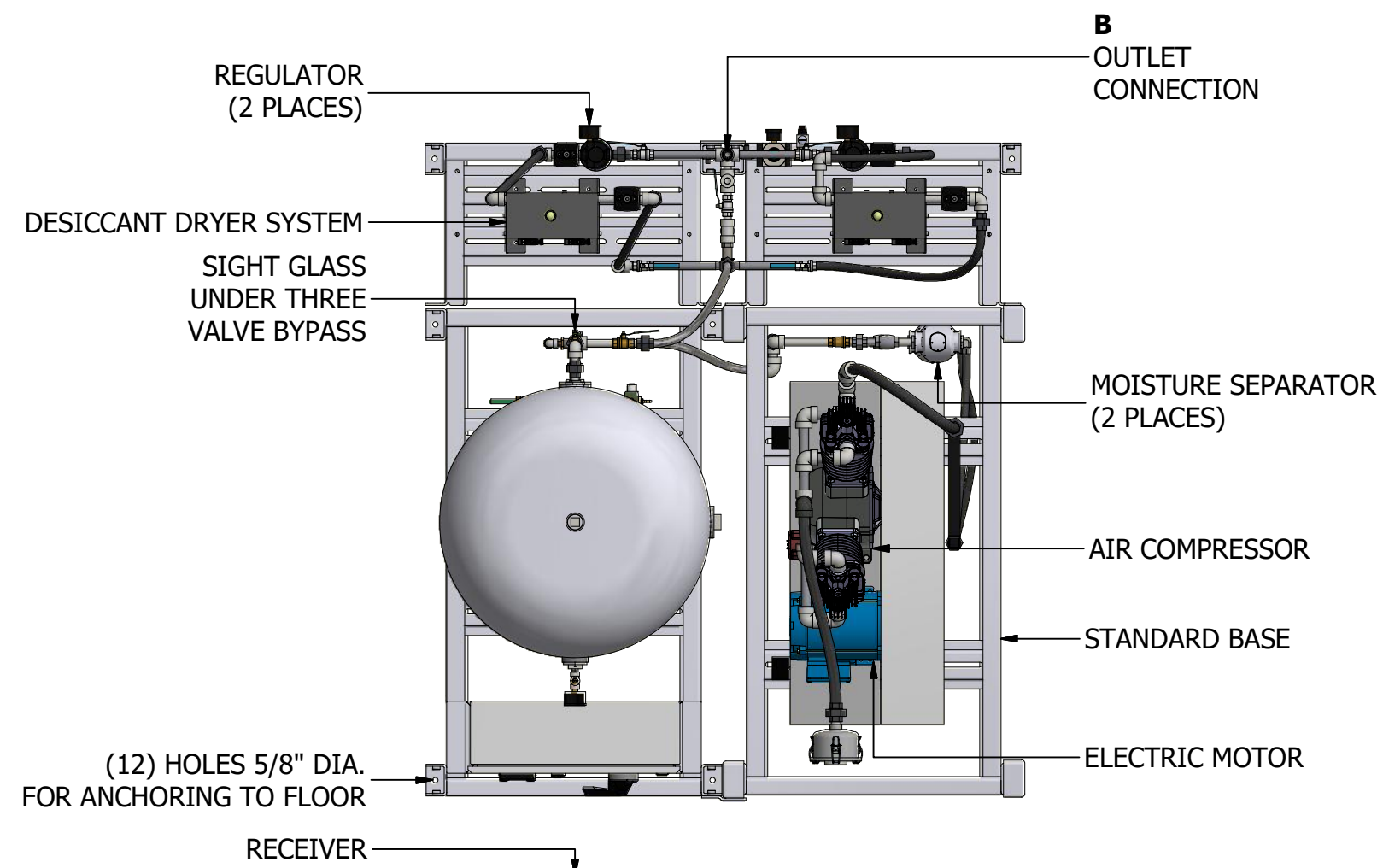

DIMENSIONS SUBJECT TO CHANGE WITHOUT NOTICE

\*SYSTEM CONFIGURATION DIFFERS FROM MODEL SHOWN

\*\*380 VOLT DATA PROVIDED AT 50Z  
ALL OTHER VOLTAGES ARE RATED AT 60HZ

ADDITIONAL MODELS AVAILABLE UPON REQUEST

MODEL	HP (kW)	A INLET NPT	B OUTLET NPT	TANK SIZE GALLON (LITRE)	COMPRESSOR SCFM (LPM)		NFPA SYSTEM CAPACITIES WITH ONE COMPRESSOR ON STANDBY (LPM)		WEIGHT IN LBS (KG)	SQ. FT. REQUIRED (M <sup>2</sup> )	SYSTEM FLA (WITH ALL COMPRESSORS RUNNING)				SYSTEM BTU/HR	SOUND LEVEL dB (A)	W (M)	L (M)	H (M)
					@ 50 psig	@ 100 psig	@ 50 psig	@ 100 psig			208V	230V	380V**	460V					
A-RED-D-200P-SS-N-010	1 (0.75)	1.25	0.5	200 (757)	4.1 (116)	3.3 (93)	4.1 (116)	3.3 (93)	1722 (781)	34.9 (3.25)	15	16	8	8	2,544	72	67 (1.70)	75 (1.91)	91 (2.31)
A-RED-D-200P-SS-N-020	2 (1.49)	1.25	0.5	200 (757)	7.8 (221)	6.6 (187)	7.8 (221)	6.6 (187)	1782 (808)	34.9 (3.25)	21	19	11	10	5,089	73	67 (1.70)	75 (1.91)	91 (2.31)
A-RED-D-200P-SS-N-030	3 (2.24)	1.25	0.5	200 (757)	10.1 (286)	9.4 (266)	10.1 (286)	9.4 (266)	1866 (846)	34.9 (3.25)	27	25	13	12	7,633	74	67 (1.70)	75 (1.91)	91 (2.31)
A-RED-D-200P-SS-N-050	5 (3.73)	1.25	0.5	200 (757)	18.4 (521)	15.4 (436)	18.4 (521)	15.4 (436)	2026 (919)	34.9 (3.25)	41	36	19	18	12,722	76	67 (1.70)	75 (1.91)	91 (2.31)
A-RED-D-200P-SS-N-075	7.5 (5.59)	2.0	0.5	200 (757)	28.1 (796)	23.3 (660)	28.1 (796)	23.3 (660)	2186 (992)	34.9 (3.25)	55	48	25	24	19,083	78	67 (1.70)	75 (1.91)	91 (2.31)
A-RED-D-200P-SS-N-100	10 (7.46)	2.0	0.5	200 (757)	37.1 (1051)	32.5 (920)	37.1 (1051)	32.5 (920)	2462 (1117)	34.9 (3.25)	71	63	37	32	25,444	81	67 (1.70)	75 (1.91)	91 (2.31)
A-RED-D-200P-SS-N-150	15 (11.2)	2.0	1.0	200 (757)	54.7 (1549)	47.7 (1351)	54.7 (1549)	47.7 (1351)	2600 (1179)	35.8 (3.33)	100	87	46	44	38,167	84	67 (1.70)	77 (1.96)	91 (2.31)
A-RED-D-200P-SS-N-200	20 (14.9)	2.0	1.0	200 (757)	73.1 (2070)	61.8 (1750)	73.1 (2070)	61.8 (1750)	3010 (1365)	74.3 (6.90)	138	112	-	56	50,899	84	123 (3.12)	87 (2.21)	100 (2.54)



85 Fulton Way, Richmond Hill Ontario, L4B 2N4 Canada  
71 East Industry Court Deer Park, NY 11729  
Direct Tel: 905.764.0800  
Tel: 1.877.462.6426  
Fax: 1.866.440.4986



# QUADRAPLEX RECIPROCATING AIR PLANT WITH DESICCANT AIR TREATMENT SYSTEM (1.0 HP - 20.0 HP)

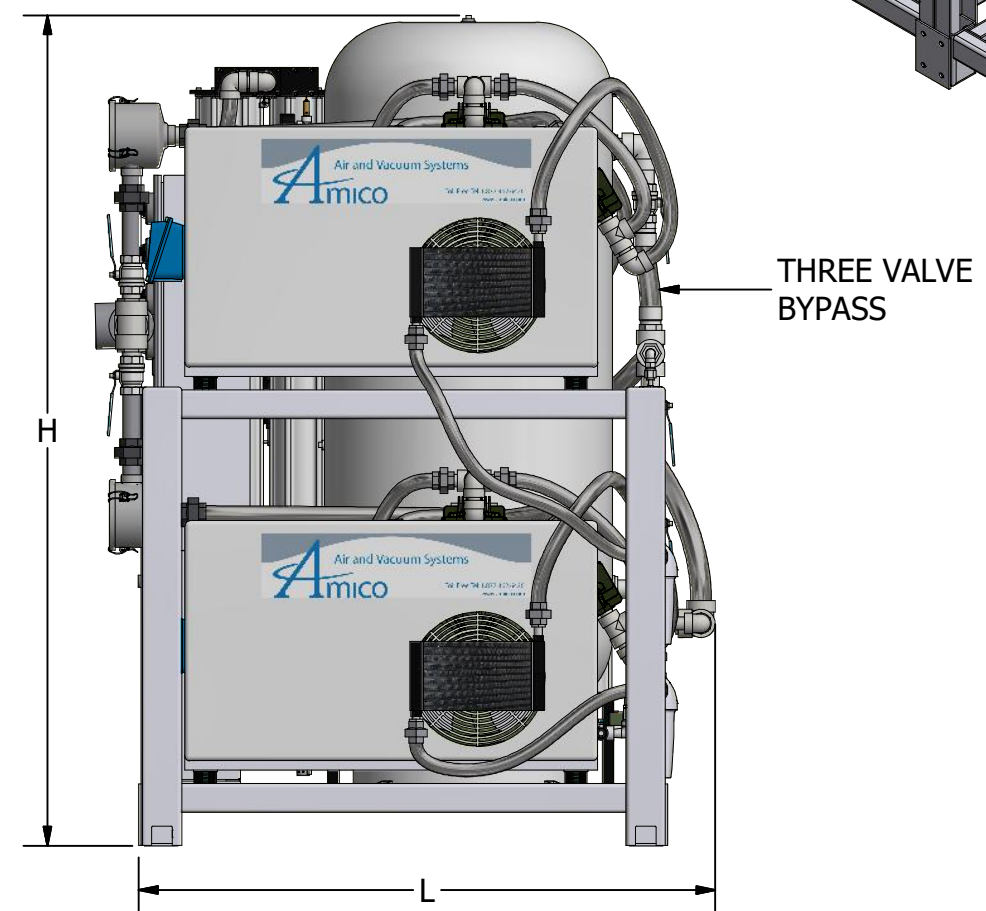
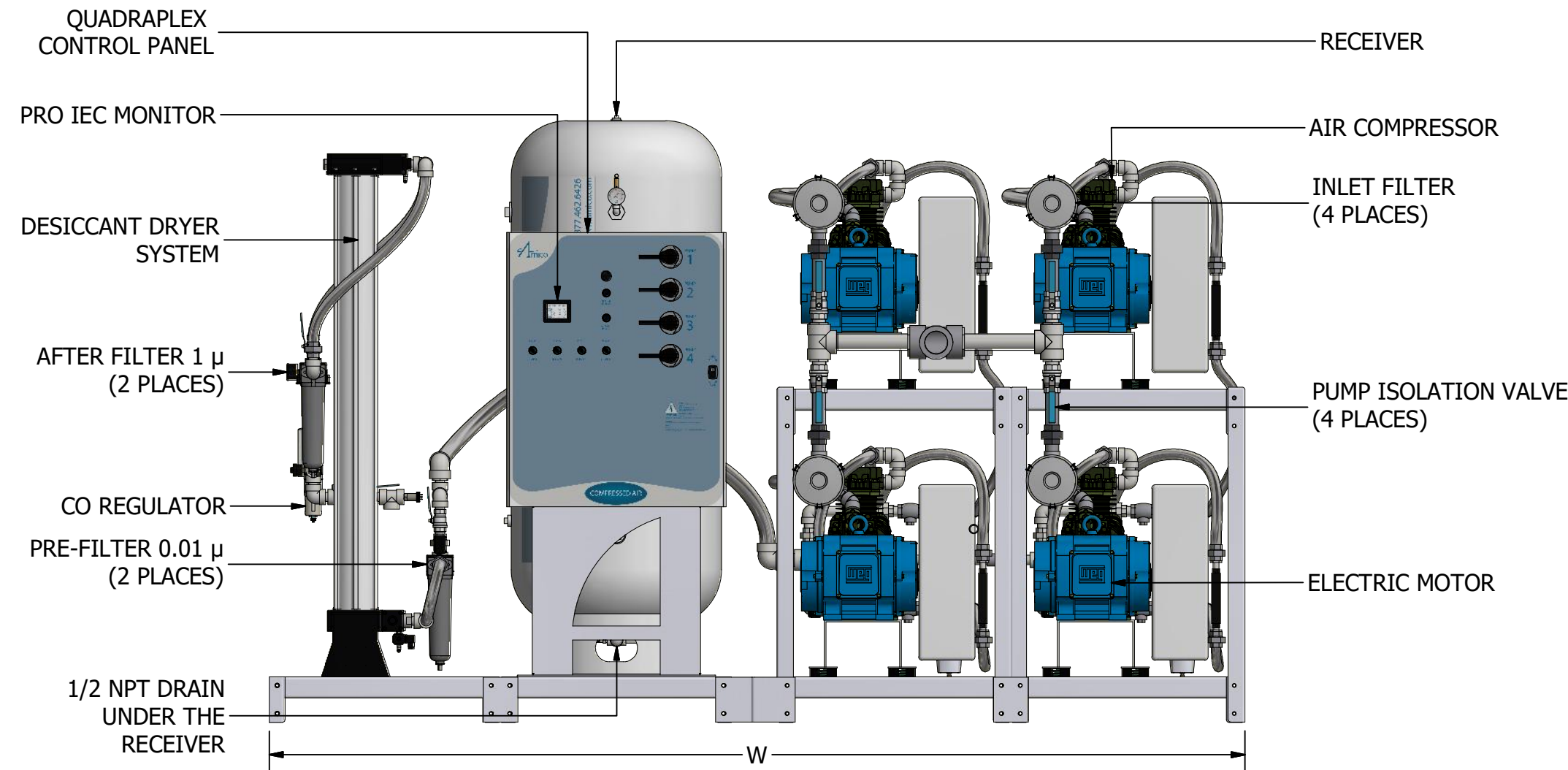
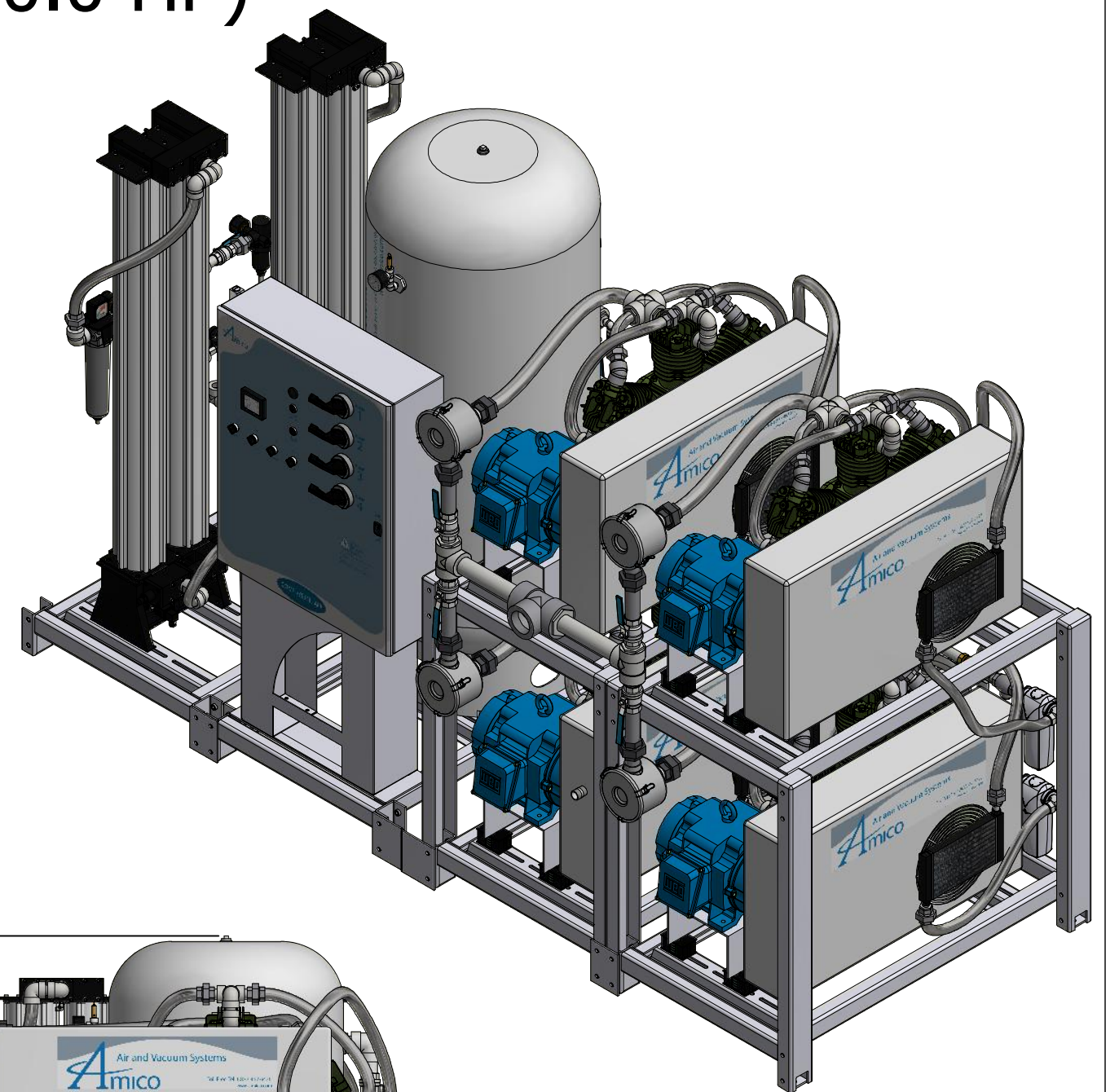
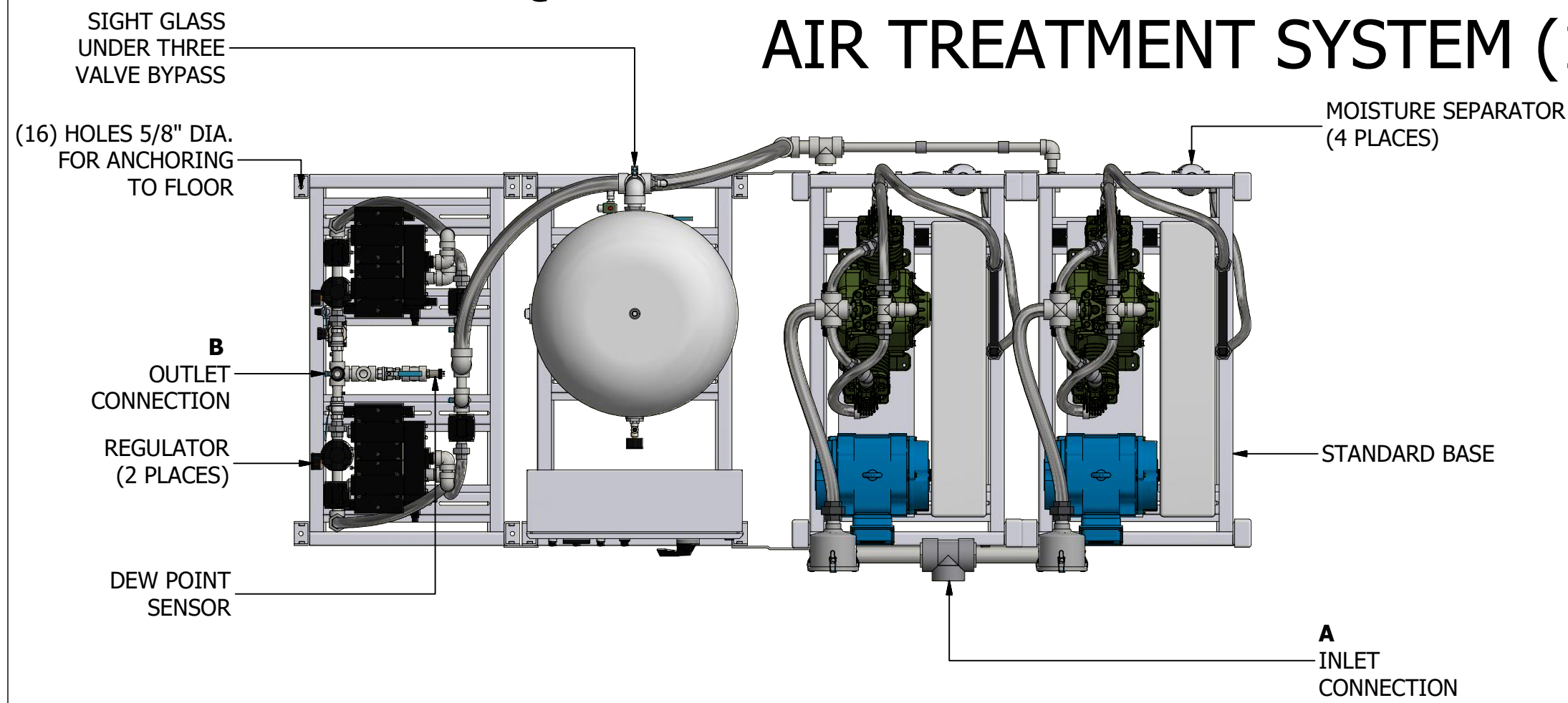

DIMENSIONS SUBJECT TO CHANGE WITHOUT NOTICE

\*SYSTEM CONFIGURATION DIFFERS FROM MODEL SHOWN

\*\*380 VOLT DATA PROVIDED AT 50HZ  
ALL OTHER VOLTAGES ARE RATED AT 60HZ

ADDITIONAL MODELS AVAILABLE UPON REQUEST

MODEL	HP (kW)	A INLET NPT	B OUTLET NPT	TANK SIZE GALLON (LITRE)	COMPRESSOR SCFM (LPM)		NFPA SYSTEM CAPACITIES WITH ONE COMPRESSOR ON STANDBY (LPM)		WEIGHT IN LBS (KG)	SQ. FT. REQUIRED (M <sup>2</sup> )	SYSTEM FLA (WITH ALL COMPRESSORS RUNNING)				SYSTEM BTU/HR	SOUND LEVEL dB (A)	W (M)	L (M)	H (M)
					@ 50 psig	@ 100 psig	@ 50 psig	@ 100 psig			208V	230V	380V**	460V					
A-RED-Q-200P-SS-N-010*	1 (0.75)	1.5	0.5	200 (757)	4.1 (116)	3.3 (93)	12.3 (348)	9.9 (280)	2608 (1183)	56.3 (5.23)	27	27	16	16	7,632	77	108 (2.74)	75 (1.91)	91 (2.31)
A-RED-Q-200P-SS-N-020*	2 (1.49)	1.5	0.5	200 (757)	7.8 (221)	6.6 (187)	23.4 (663)	19.8 (561)	2762 (1253)	56.3 (5.23)	38	34	21	19	15,267	78	108 (2.74)	75 (1.91)	91 (2.31)
A-RED-Q-200P-SS-N-030*	3 (2.24)	1.5	0.5	200 (757)	10.1 (286)	9.4 (266)	30.3 (858)	28.2 (799)	2974 (1349)	56.3 (5.23)	50	45	26	25	22,899	79	108 (2.74)	75 (1.91)	91 (2.31)
A-RED-Q-200P-SS-N-050*	5 (3.73)	1.5	1.0	200 (757)	18.4 (521)	15.4 (436)	55.2 (1563)	46.2 (1308)	3348 (1519)	57.8 (5.37)	77	68	37	36	38,166	81	108 (2.74)	77 (1.96)	91 (2.31)
A-RED-Q-200P-SS-N-075*	7.5 (5.59)	3.0	1.0	200 (757)	28.1 (796)	23.3 (660)	84.3 (2387)	69.9 (1979)	3900 (1769)	68.5 (6.37)	107	92	51	48	57,249	83	141 (3.58)	70 (1.78)	91 (2.31)
A-RED-Q-200P-SS-N-100*	10 (7.46)	3.0	1.0	200 (757)	37.1 (1051)	32.5 (920)	111.3 (3152)	97.5 (2761)	4358 (1977)	68.5 (6.37)	138	122	75	63	76,332	86	141 (3.58)	70 (1.78)	91 (2.31)
A-RED-Q-200P-SS-N-150	15 (11.2)	3.0	1.5	200 (757)	54.7 (1549)	47.7 (1351)	164.1 (4647)	143.1 (4052)	5146 (2334)	69.0 (6.43)	196	170	92	87	114,501	89	142 (3.61)	70 (1.78)	91 (2.31)
A-RED-Q-200P-SS-N-200*	20 (14.9)	3.0	1.5	200 (757)	73.1 (2070)	61.8 (1750)	219.3 (6210)	185.4 (5250)	6288 (2852)	105.7 (9.83)	272	221	-	112	152,667	89	175 (4.45)	87 (2.21)	100 (2.54)



85 Fulton Way, Richmond Hill  
Ontario, L4B 2N4 Canada  
71 East Industry Court  
Deer Park, NY 11729  
Direct Tel: 905.764.0800  
Tel: 1.877.462.6426  
Fax: 1.866.440.4986



# TRIPLEX RECIPROCATING AIR PLANT WITH DESICCANT AIR TREATMENT SYSTEM (1.0 HP - 20.0 HP)

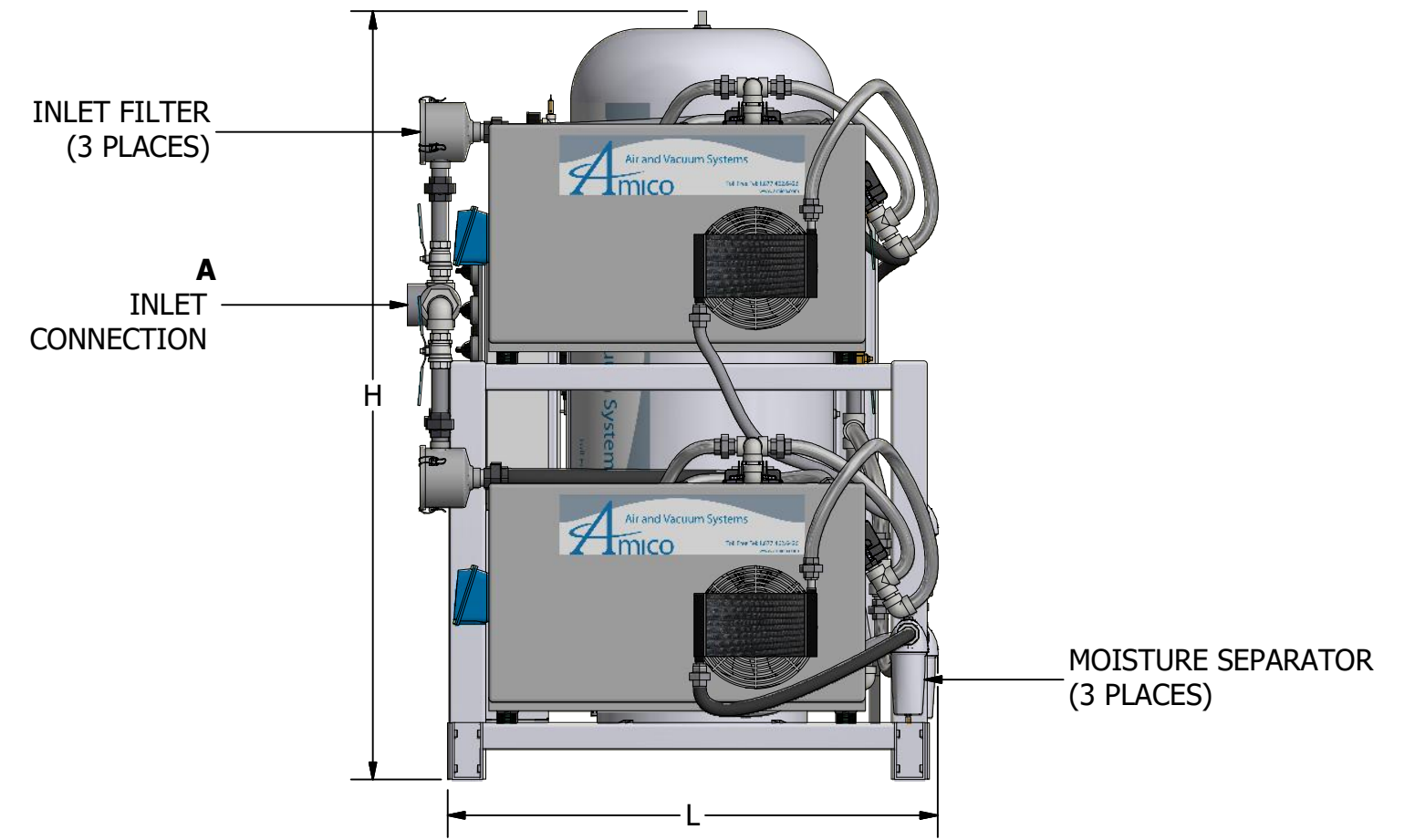
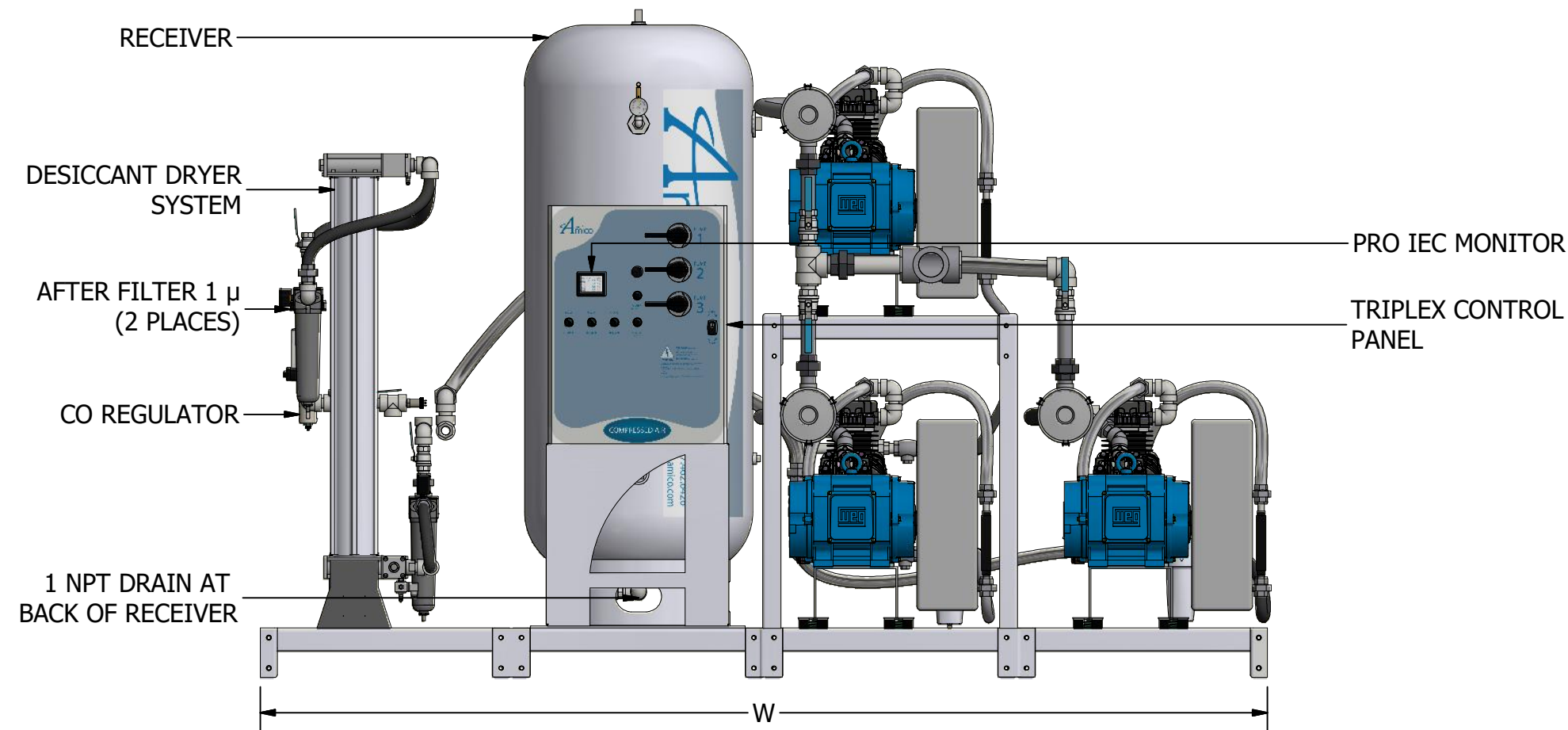
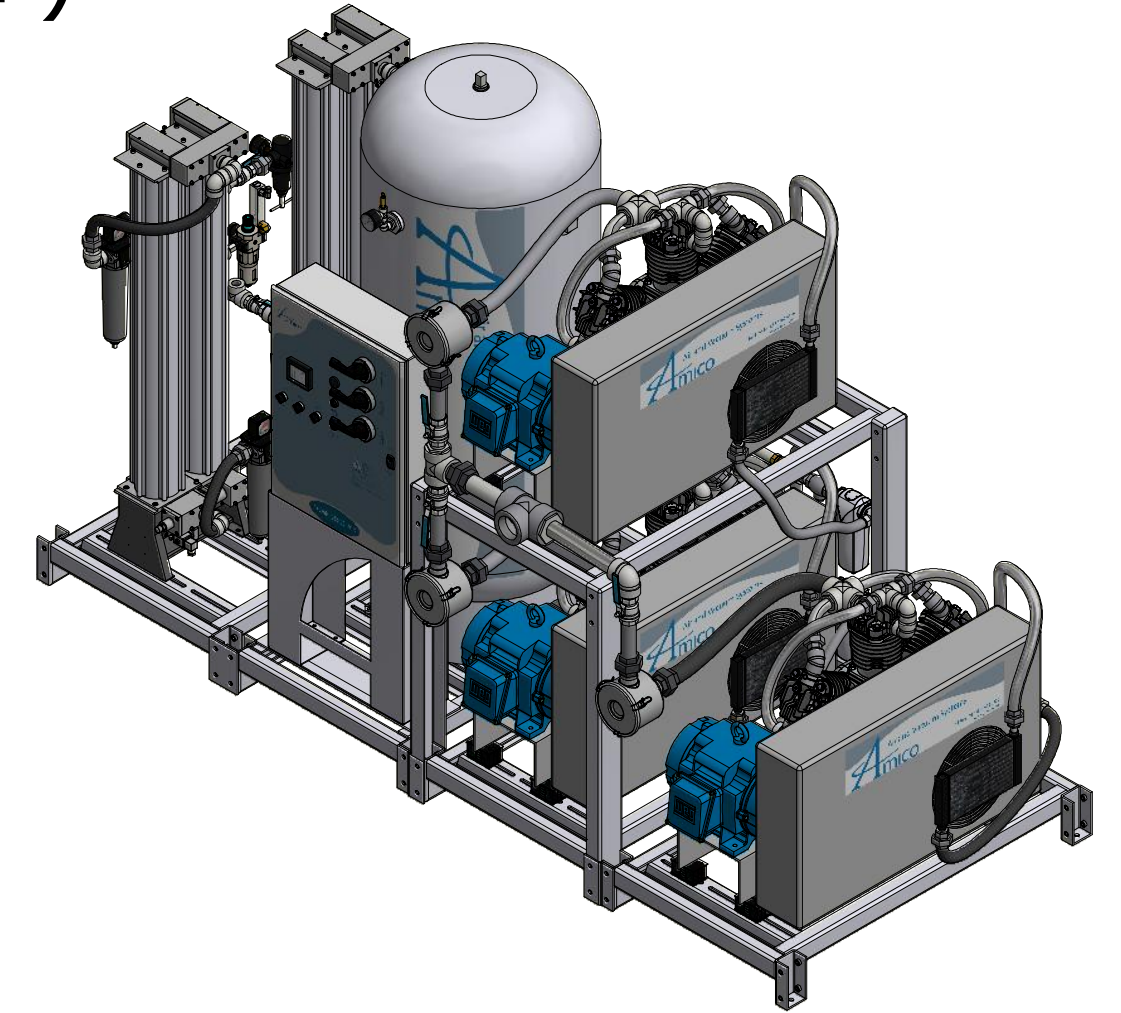
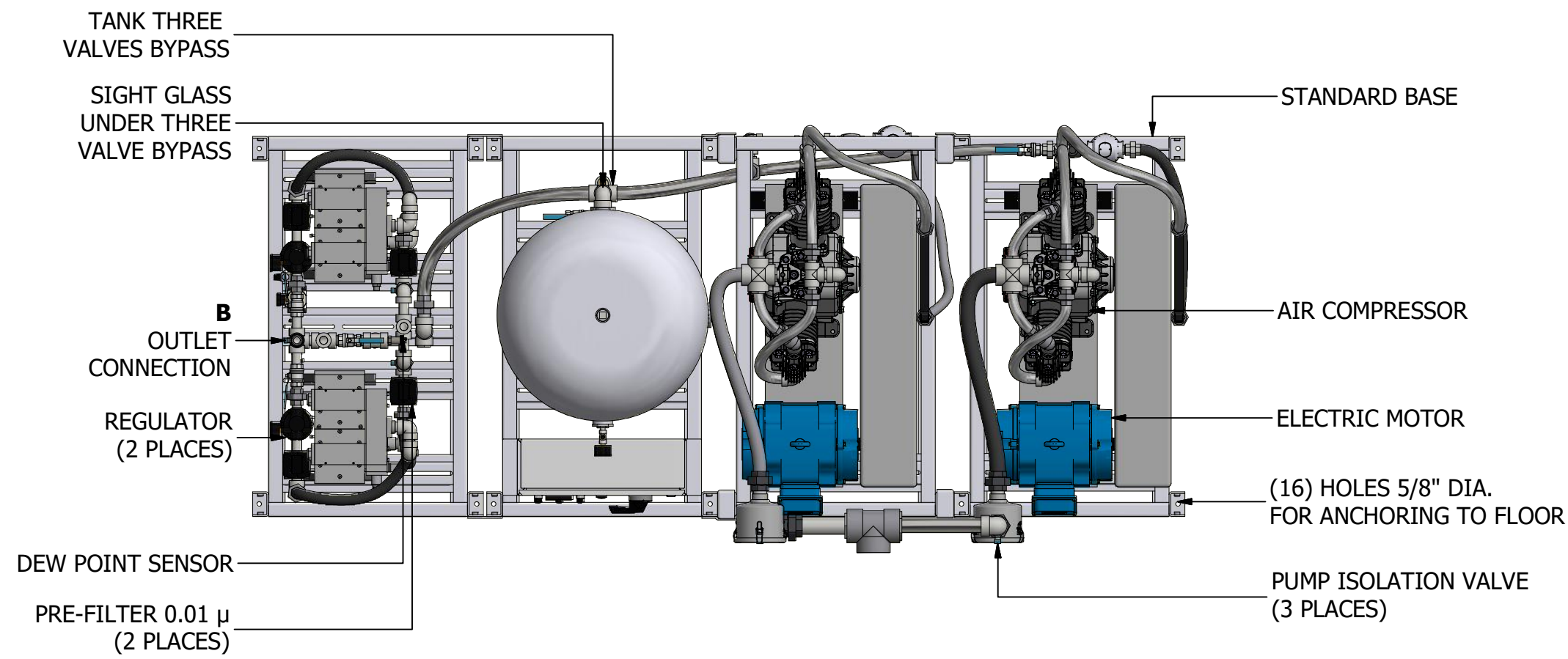

DIMENSIONS SUBJECT TO CHANGE WITHOUT NOTICE

\*SYSTEM CONFIGURATION DIFFERS FROM MODEL SHOWN

\*\*380 VOLT DATA PROVIDED AT 50HZ  
ALL OTHER VOLTAGES ARE RATED AT 60HZ

ADDITIONAL MODELS AVAILABLE UPON REQUEST

MODEL	HP (KW)	A INLET NPT	B OUTLET NPT	TANK SIZE GALLON (LITRE)	COMPRESSOR SCFM (LPM)		NFPA SYSTEM CAPACITIES WITH ONE COMPRESSOR ON STANDBY (LPM)		WEIGHT IN LBS (KG)	SQ. FT. REQUIRED (M <sup>2</sup> )	SYSTEM FLA (WITH ALL COMPRESSORS RUNNING)				SYSTEM BTU/HR	SOUND LEVEL dB (A)	W (M)	L (M)	H (M)
					@ 50 psig	@ 100 psig	@ 50 psig	@ 100 psig			208V	230V	380V**	460V					
A-RED-T-200P-SS-N-010*	1 (0.75)	1.5	0.5	200 (757)	4.1 (116)	3.3 (93)	8.2 (232)	6.6 (187)	2069 (938)	52.1 (4.85)	19	19	10	10	5,088	75	100 (2.54)	75 (1.91)	91 (2.31)
A-RED-T-200P-SS-N-020*	2 (1.49)	1.5	0.5	200 (757)	7.8 (221)	6.6 (187)	15.6 (442)	13.2 (374)	2193 (995)	52.1 (4.85)	27	25	14	12	10,178	76	100 (2.54)	75 (1.91)	91 (2.31)
A-RED-T-200P-SS-N-030*	3 (2.24)	1.5	0.5	200 (757)	10.1 (286)	9.4 (266)	20.2 (572)	18.8 (532)	2319 (1052)	52.1 (4.85)	36	33	17	16	15,266	77	100 (2.54)	75 (1.91)	91 (2.31)
A-RED-T-200P-SS-N-050*	5 (3.73)	1.5	0.5	200 (757)	18.4 (521)	15.4 (436)	36.8 (1042)	30.8 (872)	2568 (1165)	52.1 (4.85)	57	50	26	25	25,444	79	100 (2.54)	75 (1.91)	91 (2.31)
A-RED-T-200P-SS-N-075*	7.5 (5.59)	2.0	1.0	200 (757)	28.1 (796)	23.3 (660)	56.2 (1591)	46.6 (1320)	2993 (1358)	53.5 (4.98)	79	68	36	34	38,166	81	100 (2.54)	77 (1.96)	91 (2.31)
A-RED-T-200P-SS-N-100*	10 (7.46)	2.0	1.0	200 (757)	37.1 (1051)	32.5 (920)	74.2 (2101)	65.0 (1841)	3374 (1530)	53.5 (4.98)	102	91	54	45	50,888	84	100 (2.54)	77 (1.96)	91 (2.31)
A-RED-T-200P-SS-N-150	15 (11.2)	3.0	1.0	200 (757)	54.7 (1549)	47.7 (1351)	109.4 (3098)	95.4 (2701)	3809 (1728)	60.0 (5.58)	146	127	67	63	76,334	87	133 (3.38)	65 (1.65)	91 (2.31)
A-RED-T-200P-SS-N-200*	20 (14.9)	3.0	1.5	200 (757)	73.1 (2070)	61.8 (1750)	146.2 (4140)	123.6 (3500)	4409 (2000)	105.7 (9.43)	203	165	-	82	101,778	87	175 (4.45)	87 (2.21)	100 (2.54)



85 Fulton Way, Richmond Hill  
Ontario, L4B 2N4 Canada  
71 East Industry Court  
Deer Park, NY 11729  
Direct Tel: 905.764.0800  
Tel: 1.877.462.6426  
Fax: 1.866.440.4986